

# PK-88 TWT Bruiser Assembly Instructions

<b>PARTS LIST:</b>	<b>1 BT-7.51-30" Airframe Tube</b>	<b>1 MMT-2.14 Motor Mount Tube</b>	<b>1 LL-50 Launch Lug</b>
	<b>1 Shock Cord &amp; Mount Assy.</b>	<b>1 Set of fins with LOC-N-FIN™</b>	<b>1 LPHPC-60 Parachute</b>
	<b>1 CR-7.51-2.14 Centering Ring</b>	<b>1 PNC-7.51 Plastic Nose Cone</b>	<b>1 SBT-7.51-3S, 30" Slotted Airframe tube</b>
	<b>1 TC-7.51 Tube Coupler 15"</b>	<b>TC-7.51 Tube Coupler 15"</b>	<b>1 CR-7.51-2.14 Bottom Centering Ring</b>

- ◇ Due to the high thrust motors that can be flown in this kit, it is strongly recommended that epoxy be used throughout its entire construction.
- ◇ Before beginning construction, read over assembly instructions to familiarize you with the proper construction sequence. Check cross section diagram and LOC-N-FIN picture for fin positions and motor mount/centering ring placement inside the main airframe.
- ◇ **TEST FIT PARTS BEFORE BONDING TOGETHER WITH EPOXY!!!!**
- ◇ It may be necessary to lightly sand some parts to obtain a proper fit.
- ◇ The following items will be needed for the construction & finishing of this kit: 12" ruler, Modeling knife, Pen or pencil, Masking tape, Sanding sealer, Paint brushes (assorted sizes), Sandpaper (coarse, medium & fine), Primer and paint, Epoxy (6 or 20 minute), Dremel tool.

## Main Airframe Assembly Instructions

- Using fine sandpaper, sand the outside of the main airframe, motor mount tube, and launch lug for better epoxy adhesion. Glue the tube coupler half way into the slotted airframe section on the end opposite of the slots and allow to dry.
- The top centering ring has a hole in it for the shock cord mounting eyebolt. Install the eyebolt with a washer on each side of the plate and secure with the .25"x20 nut. Sand the ends of the motor mount tube to allow better epoxy adhesion. Slide one end of the motor mount into the top centering ring and push through such that about 1/8" of the tube extends through the eyebolt side.
- With the new LOC-N-FIN arrangement, the traditional method of assembling the motor mount and sliding it into place will not work on this model. The aft centering ring should be sanded so that the motor mount slides easily into the 54mm center. Place 2 pieces of masking tape 180 degrees apart on the aft ring so that you can pull it out of the model in the next step.
- Dry fit the upper centering ring and motor tube into place and slide on the aft ring to be sure the motor mount is properly aligned. Slide this assembly in place taking care to keep the tape tabs exposed – once the upper ring is epoxied in place, you will want to pull the aft ring off to install the fins and fillet the bottom of the ring and mount.
- Once you are satisfied with the placement, epoxy the top centering ring to motor mount joints in place with nice fillets – take care not to get epoxy into the motor tube. Set aside to cure.
- Turn the model over and pull off the aft ring by pulling the tapes. Remove and discard the tape. If for some reason this step fails, drill a screw into the aft ring and use it to pull off the ring. The motor mount is now properly in place. With the aft ring removed, epoxy the underside of the top ring and motor mount joints with a nice fillet.
- Slide a fin into one of the 3 slots and test fit the keeper. Sanding the edge of the keeper helps as this is a tight joint. It is helpful to slant the fin about 30 degrees or so to get it started, once in place the fin will automatically snap perpendicular to the tube. When you are satisfied with the fit, epoxy the fin and keeper and assemble. Repeat for the remaining 2 fins. Give everything a nice fillet if you like and prepare to install the aft ring.
- Slather some epoxy on the rear end of the rocket and motor mount tube and install the aft ring to the desired depth (depending on your method of motor retention this can vary from flush to 1/8" extended). Allow to cure.
- Once cured, apply additional epoxy fillets to the joints and along the fin's root edges for maximum strength.
- Glue the 751-30" airframe tube to the completed motor/fin section coupler to complete the 60" main airframe.
- Sight in the high point (center of the airframe's diameter) of the airframe between any 2 fins and from 4" up from the airframe's aft end, make a small pencil mark. From this mark, make two separate straight 3" lines. The first line starts at this 4" line and extends to 7". The next mark starts 7" up from the end of this mark. Cut the launch lug in half at an angle to reduce drag. Epoxy each half of the launch lug directly on the lines, making sure that they are in line and parallel to the airframe. Set aside to cure in the horizontal position.
- Give the launch lug joints an additional fillet for maximum strength. Make sure not to get epoxy inside of the launch lug or it will interfere with your flight.
- Seal fins and launch lug with sanding sealer using a brush. Sand lightly between coats to fill pores and obtain a smooth finish.

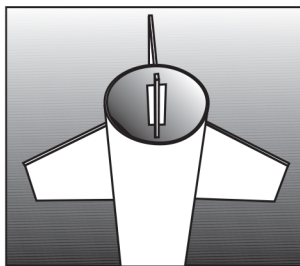

## Main Airframe Assembly Instructions , Continued

- Lightly sand the nosecone with fine sandpaper to remove molding seam line.
- When you are satisfied with the smooth and sanded finish of your model it is ready to paint in the colors of your choice. Decal graphics are available at [www.locprecision.com](http://www.locprecision.com) if so desired.
- Connect one end of the shock cord to the eyebolt and the other end to the eyelet of the nosecone using double knots at each end.
- Attach Parachute to the shock cord approximately 4' from the nosecone.
- Select a motor for first flight. Because of all the different motor combinations available (with varying motor lengths), this kit uses no motor blocks. Instead, wrap .5" wide masking tape around the nozzle end of each motor to a diameter equal to that of the motor mount tube. This will keep the motor from pushing forward upon ignition. Friction fit the motor in place by wrapping masking tape around the motor in two places for a snug fit in the motor mount tube. This will prevent the motor from ejecting rearward upon activation of the ejection charge.
- Remember to use enough recovery wadding to protect the chute and shock cord from the hot ejection gases.
- Always follow motor manufacturer's instructions for motor use and ignition, and launch this vehicle on calm, windless days to insure safe recovery.

## CROSS SECTION OF CENTERING RINGS/ MOTOR MOUNT TUBE ASSEMBLY IN MAIN AIRFRAME.

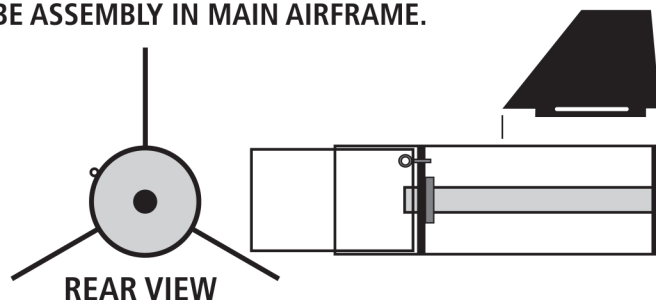

**THANK YOU FOR CHOOSING LOC PRECISION!**