

# Hydra

## HIGH POWER ROCKET KIT

The Hydra kit contains all the parts necessary\* to build a flying high power rocket:

- (1) Pre-slotted main airframe
- (1) Nose cone
- (1) Pre-slotted boattail
- (2) Large “wing” fins
- (4) Lower fins
- (1) Alignment ring
- (1) Piston ejection kit:
  - (1) Piston tube
  - (1) Slotted bulkplate
  - (1) Piston strap
  - (1) D-ring
- (1) Parachute
- (1) Motor mount tube
- (1) Notched centering ring
- (1) Shock cord
- (2) Launch lugs
- (1) Decal sheet
- (1) Instruction sheet (this one!)

\*Epoxy, paint, and motor not included.



**Please read and understand all instructions before building!**

The center of pressure (CP) of this rocket is 49 inches from nose tip. After finishing your rocket, permanently mark the center of pressure on the airframe. After loading the rocket with a motor, make sure that the center of gravity (balancing point) is at least one body diameter forward of the center of pressure mark. The center of gravity can be moved forward by adding weight to the nose cone.



# Basic Construction FAQ

The major parts involved in each step are shown shaded at the beginning of that step. Areas where epoxy should be applied are shown as well.

## PREP & ASSEMBLY

Read and understand the instruction steps fully before you begin the step.

ALWAYS sand the parts to be bonded with 100-120 grit sandpaper.

We strongly recommend you dry-fit (assemble without gluing) all parts in each step

BEFORE epoxying them together. Sand or adjust fit as needed before gluing.

Most epoxies work fine. Use 5 or 15 minute depending on how quickly you feel you can complete the step. Use longer set-time epoxy if you're unsure.

To make internal fillets to the fins deep up into the airframe, "load up" the end of a dowel with a blob of epoxy, then stick the dowel into the airframe and onto the fin joint you're working on. After depositing enough epoxy in this fashion, you can pull the dowel toward you, making a fillet with the rounded edge of the dowel.

Be sure to follow the "Do's & Don'ts" sheet provided with QT tubing.

Fins do not need to be "shaped". Lightly sand the edges to remove any manufacturing burrs.

## PAINTING/FINISHING

Before you paint the fins, scuff the entire surface with 220 grit sandpaper. This is easiest to do before mounting the fins.

Plastic nosecone imperfections can be filled with plastic model kit putty.

Stay with the same brand of paint throughout the process; primer, base color, accent colors, and clear coat. DO NOT skimp on the "shake the can for at least two minutes after the ball rattles" step! For the best finish, let each coat dry overnight and sand lightly with 320 or 400 grit sandpaper.

Apply the last color coat as heavy as possible without running or sagging. Let the paint cure for at least 48 hours before handling!

We recommend a clear coat of some sort to help protect the decals as well as "seal" their edges to help prevent them peeling off. When using any clear coat, put on only VERY thin, light coats, and wait at least 5 minutes between coats. The clear coat can damage your decals or paint if you put it on too heavily or don't wait long enough between coats!

## FINAL FITTING/PREPARATIONS FOR FLIGHT

The piston should be a smooth slip-fit in the airframe; this is critical. Sand the piston as needed so it can be easily inserted, and pulled out with just a gentle tug on the shock cord. Keep sandpaper in your range box in case you need to adjust the fit the first few times at the field to deal with differing temperature and humidity.

Couplers should also be sanded to allow easy separation of the rocket.

If the coupler or nosecone is too loose, use masking tape to build it up to a good fit. If the nosecone is too tight, sand the ribs on the shoulder until it fits well. The parts fit properly if the rocket can be held upside down and gently shaken with nothing moving or coming apart.

Ejections will leave a black, gritty residue inside the airframe. Occasionally wipe the tube interior with a damp cloth wrapped around a dowel or broomstick; allow to dry.

See our website FAQ for information about thrust rings and motor retention. Motor recommendation information is available on our website on the Specs Page.

For our complete FAQ, see the FAQ Page on our website at [www.publicmissiles.com](http://www.publicmissiles.com).

**[www.publicmissiles.com](http://www.publicmissiles.com)**

The PML Web Store and Knowledge Base

**Other items you will need:**

One set of epoxy  
One sheet each 120 and 220 sandpaper  
Ruler and pencil

Masking tape  
Cellophane tape

**Please read and understand all instructions before continuing!  
All surfaces to be bonded must be scuffed with 120 grit sandpaper.**

**Step 1**

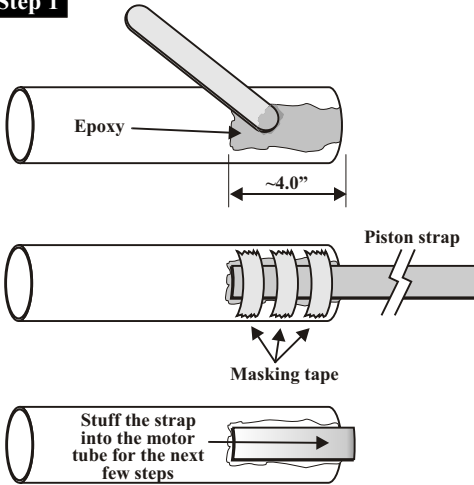

Spread a layer of epoxy about 1" wide and 4" long on the motor tube. Press 4" of the strap firmly into the epoxy on the side of the motor tube. Hold the strap in place against the tube with masking tape until the epoxy cures. Remove the masking tape. Stuff the free end of the strap into the motor tube to keep it out of the way for the next few steps.

**Step 2**

**NOTE:**

The following step **must** be completed without interruption. Please read and understand this procedure before continuing.

Stand the boat tail upright on a flat surface, preferably on a piece of wax paper. Spread a large bead of epoxy on the bottom end of the motor mount tube as illustrated.

Place the motor mount tube into the boattail and press down to make sure the tube is seated flush with the bottom. **Align the strap between the slots so that it does not interfere with fin mounting.**

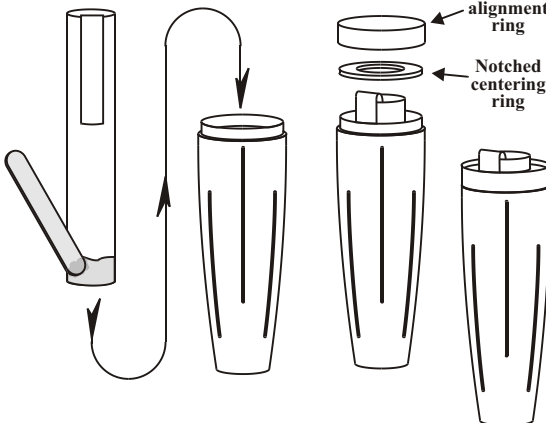

Without using any adhesive, immediately place the centering ring over the top of the motor mount tube (aligning the notch in the ring over the strap) and press down

firmly until it is in contact with the top of the boattail. Next slide the alignment ring over the centering ring, again without adhesive, and press until it is seated against the boat tail shoulder. Allow to cure. Keep the centering ring and alignment ring in position while mounting the fins.

### Step 3

**NOTE: Be sure to scuff all parts to be bonded using 100 or 120 grit sand paper.**

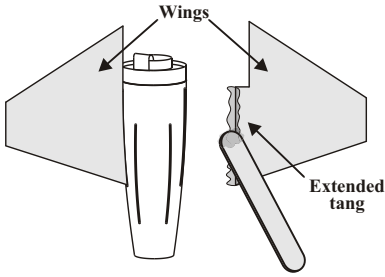

Apply a bead of epoxy to the root edge of a wing but only on the extended tang. Push the fin through one of the two upper-most slots in the boattail and against the motor mount tube. Make sure that the fin is perpendicular to the boattail. Use tape to hold the fin in position while the epoxy cures. **Do not get any epoxy on the phenolic alignment ring.** Repeat this process for both wings. Do not apply epoxy fillets to these wings until you attach the airframe in a later step. Be careful not to break the wings loose during handling.

### Step 4

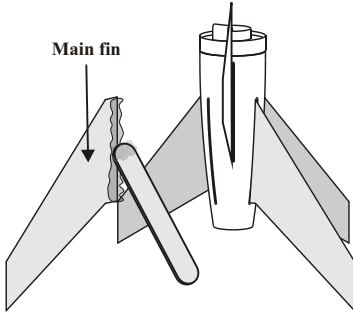

**A)** Apply a bead of epoxy to the root edge of a main fin. Push the fin through one of the four remaining slots in the boattail and against the motor mount tube. Make sure that the fin is perpendicular to the boattail. Use tape to hold the fin in position while the epoxy cures. Repeat this process for all fins.

**B)** Apply an epoxy fillet to both sides of each fin. Carefully smooth the epoxy with your finger before it begins to gel. Allow the epoxy to set up before rotating the rocket to do the next fin. Once the epoxy has fully cured, you should sand the fillet smooth with fine sandpaper.

**C)** Carefully remove the phenolic alignment ring and the centering ring from the top of the boat tail. **Apply epoxy fillets to the fin attachment points within the boat tail.** Discard the phenolic alignment ring.

**D)** Apply a bead of epoxy near the top of the motor tube and slide the centering ring back into position over the motor tube with the notch aligned with the strap. Turn the entire assembly upside-down so that the epoxy pools at the underside of the centering ring. Allow the epoxy to cure.

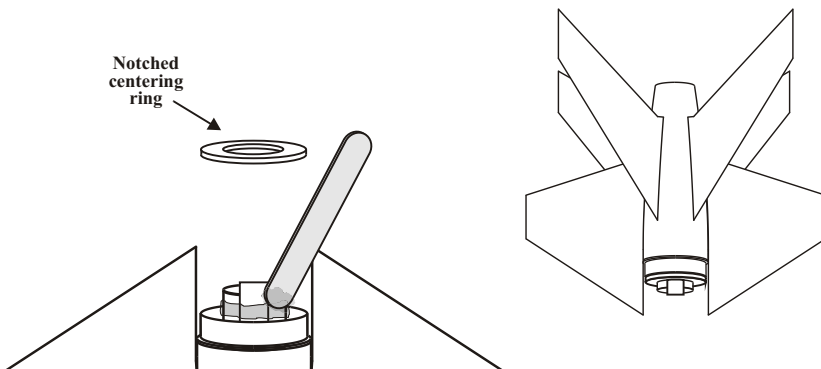

## Step 5

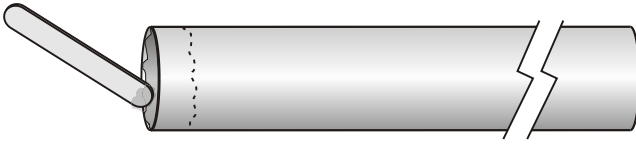

Spread a layer of epoxy around the inside circumference of one end of the main airframe to a depth of about 1". With the tail section standing upright, carefully push the airframe on to the shoulder of the boattail until it is firmly in place. Allow the epoxy to cure.

Apply an epoxy fillet to both sides of each wing. Carefully smooth the epoxy with your finger before it begins to gel. Allow the epoxy to set up before rotating the rocket to do the next fin. Once the epoxy has fully cured, you should sand the fillet smooth with fine sandpaper.

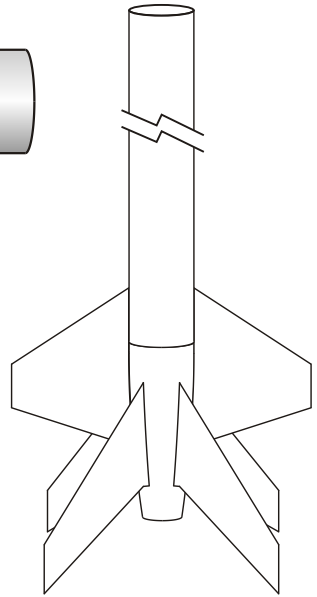

## Step 6

**NOTE: In this step you will be using the free end of the strap that you mounted to the motor tube assembly.**

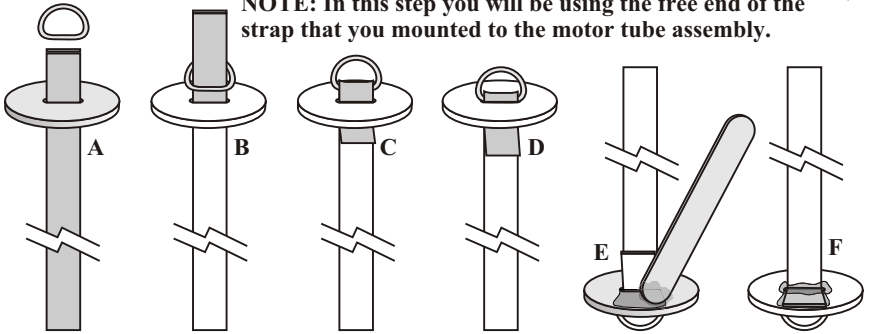

**A)** Pull the free end of the strap through the slot in the piston bulk plate.

**B)** Slip the metal "D" ring over the strap.

**C)** Feed the strap back through the slot.

**D)** Pull on the strap until the "D" ring is wedged at the slot.

**E)** Flip the assembly over. Spread a layer of epoxy on the underside of the piston plate as shown. Fold the short end of the strap flat against the piston plate and press it into the epoxy. You can use a clamp to hold the strap in the epoxy while it sets.

**F)** When the epoxy has cured, pull the strap until the "D" ring is wedged tight at the slot. Apply epoxy to the strap at the "D" ring.

**G)** Epoxy the piston plate inside the piston body 1/8" from the top.

**H)** Apply an epoxy fillet to both sides of the piston plate.

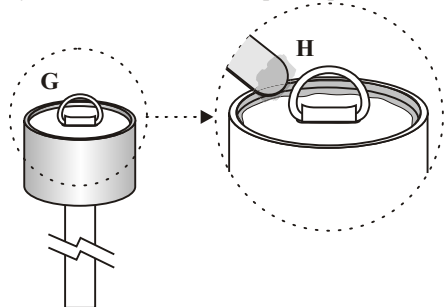

## Step 7

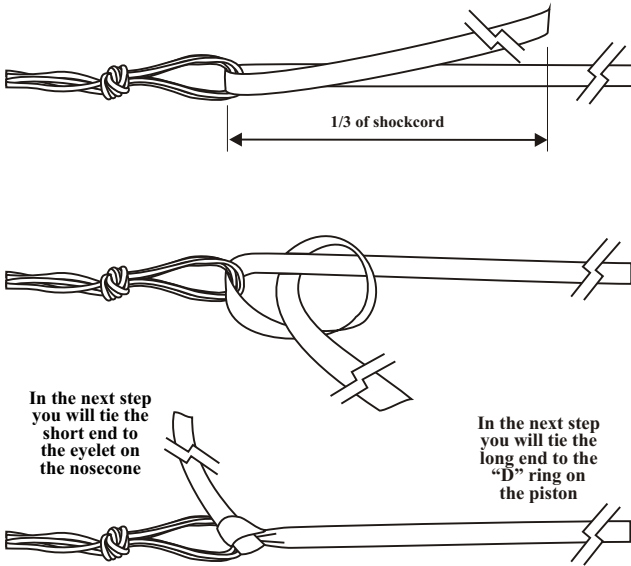

Prepare the parachute per the parachute instructions. Thread the shock cord through the loop you made in the parachute shroud lines and tie it using the knot illustrated on the left. Note that the chute should be attached to the shock cord at about the 1/3 point of the shock cord. Alternatively, you can tie the shock cord to a "kwik-link" and then attach the "kwik-link" to the loop in the shroud lines.

In the next step you will tie the short end to the eyelet on the nosecone

In the next step you will tie the long end to the "D" ring on the piston

## Step 8

Using a sharp pointed knife, remove the flash from the eyelet at the base of the nosecone. If necessary, you can enlarge the eyelet by using the knife to extend the opening toward the nosecone body (not toward the edges as this will weaken the eyelet). Thread the shock cord through the eyelet and tie it to the nosecone using the knot illustrated below. Add a drop of epoxy to the trailer at the knot to make sure the knot never slips. DO NOT saturate the knot with epoxy or CA. Alternatively, you can tie the shock cord to a "kwik-link" and then attach the "kwik-link" to the nosecone eyelet.

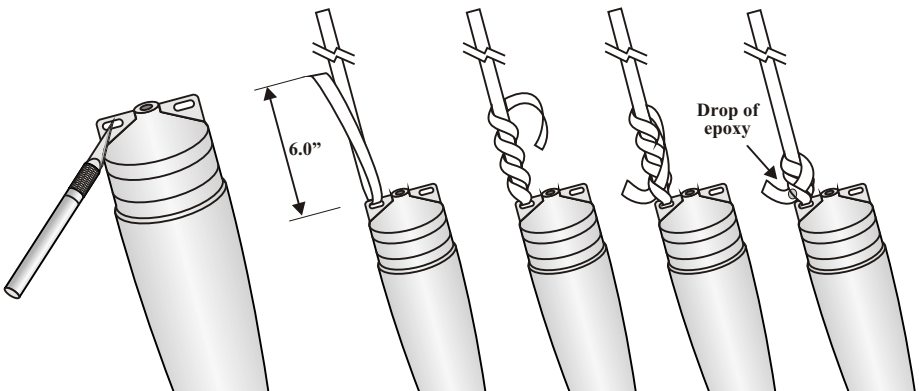

## Step 9

Thread the long end of the shock cord through the “D” ring and tie it using the knot illustrated below. Alternatively, you can tie the shock cord to a “kwik-link” and then attach the “kwik-link” to the “D” ring. Use the same knot to attach the other end of the shock cord to the eye bolt on the payload section.

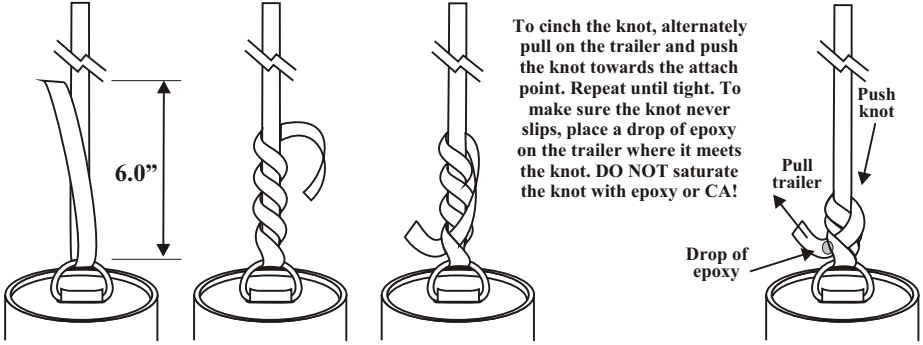

## Step 10

*The rocket drawn below is generic and may not represent the kit you are building. It is intended to provide a general guideline for mounting launch lugs to this or any rocket.*

Sand the entire surface of each launch lug with 100 or 120 grit sandpaper. Epoxy one launch lug in place 1 to 2 inches from the bottom of the rocket and the other launch lug at about the CG (balancing point) of the rocket (without motor installed). If the rocket you are building has a tailcone or boattail, then mount the first lug just above it. Be sure the lugs are perfectly in line with each other, parallel to the airframe and not in line with a fin. Apply an epoxy fillet to both sides of each lug.

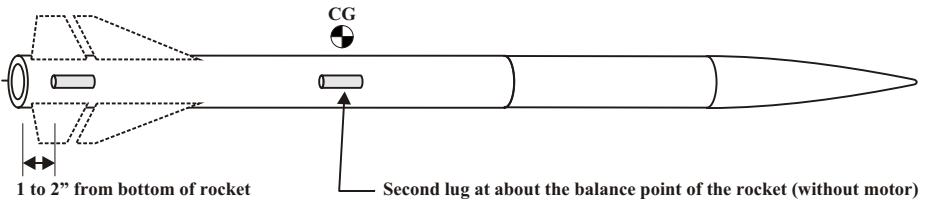

# Hydro

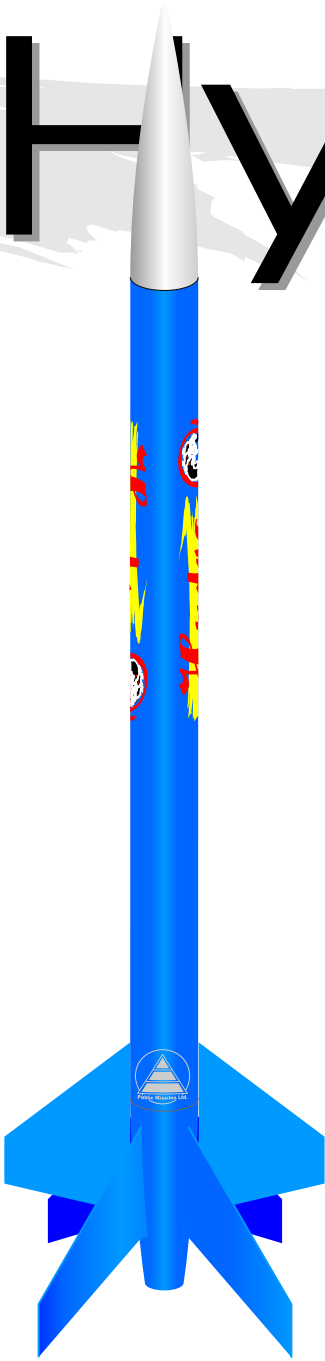

[www.publicmissiles.com](http://www.publicmissiles.com)

The PML Web Store and Knowledge Base

Revised 3.27.00