

Nimbus



HIGH POWER ROCKET KIT

Parts list:

Pre-slotted airframe

(2) Recovery airframes (both 18" long)

Nose cone

(3) Fins

CPR-3000 system:

Aluminum Threaded Airframe Coupler

Aluminum Threaded Sleeve

Fore Altimeter Mount

Aft Altimeter Mount

(2) Charge Cylinder Holders

(2) Charge Cylinder Canisters

(4) Vinyl Charge Canister Caps

Slotted Altimeter Mounting Tube 1.5" x 7"

Mounting Tube 1.5" x 4" long

Coupler Tube 1.5" x 2" long

Airframe Coupler 1-7/8" long

Airframe Coupler Tube

O-ring for Airframe Coupler

Small O-ring 1-1/2" dia.

Small O-ring 1-3/8" dia.

(2) Standard Centering Rings

(2) Notched Centering Rings

(2) Piston Systems including:

Piston Body (tube)

Piston Plate

D-ring

Piston Strap (red or black)

Strap for fin unit (16" long)

D-ring (for strap above)

Slotted Bulk Plate (for airframe coupler)

(4) Small Socket Head Screws

Allen Wrench

Safety Switch

Safety Switch Stand-Off

Safety Switch Wire

(2) Safety Switch Mounting Screws

Drogue Streamer

Main Parachute

(2) Launch lugs

(2) Shock Cord (Tubular Nylon)

(2) Kwik-Links

Instruction manual (this one)

CPR-3000 Logo Decal

Please read and understand all instructions before building!

The center of pressure (CP) of this rocket is 60 inches from nose tip. After finishing your rocket, permanently mark the center of pressure on the airframe. After loading the rocket with a motor, make sure that the center of gravity (balancing point) is at least one body diameter forward of the center of pressure mark. The center of gravity can be moved forward by adding weight to the nose cone.



Basic Construction FAQ

The major parts involved in each step are shown shaded at the beginning of that step. Areas where epoxy should be applied are shown as well.

PREP & ASSEMBLY

Read and understand the instruction steps fully before you begin the step.

ALWAYS sand the parts to be bonded with 100-120 grit sandpaper.

We strongly recommend you dry-fit (assemble without gluing) all parts in each step

BEFORE epoxying them together. Sand or adjust fit as needed before gluing.

Most epoxies work fine. Use 5 or 15 minute depending on how quickly you feel you can complete the step. Use longer set-time epoxy if you're unsure.

To make internal fillets to the fins deep up into the airframe, "load up" the end of a dowel with a blob of epoxy, then stick the dowel into the airframe and onto the fin joint you're working on. After depositing enough epoxy in this fashion, you can pull the dowel toward you, making a fillet with the rounded edge of the dowel.

Fins do not need to be "shaped". Lightly sand the edges to remove any manufacturing burrs.

PAINTING/FINISHING

Before you paint the fins, scuff the entire surface with 220 grit sandpaper. This is easiest to do before mounting the fins.

Plastic nosecone imperfections can be filled with plastic model kit putty.

Stay with the same brand of paint throughout the process; primer, base color, accent colors, and clear coat. DO NOT skimp on the "shake the can for at least two minutes after the ball rattles" step! For the best finish, let each coat dry overnight and sand lightly with 320 or 400 grit sandpaper.

Apply the last color coat as heavy as possible without running or sagging. Let the paint cure for at least 48 hours before handling!

We recommend a clear coat of some sort to help protect the decals as well as "seal" their edges to help prevent them peeling off. When using any clear coat, put on only VERY thin, light coats, and wait at least 5 minutes between coats. The clear coat can damage your decals or paint if you put it on too heavily or don't wait long enough between coats!

FINAL FITTING/PREPARATIONS FOR FLIGHT

The piston should be a smooth slip-fit in the airframe; this is critical. Sand the piston as needed so it can be easily inserted, and pulled out with just a gentle tug on the shock cord. Keep sandpaper in your range box in case you need to adjust the fit the first few times at the field to deal with differing temperature and humidity.

Couplers should also be sanded to allow easy separation of the rocket.

If the coupler or nosecone is too loose, use masking tape to build it up to a good fit. If the nosecone is too tight, sand the ribs on the shoulder until it fits well. The parts fit properly if the rocket can be held upside down and gently shaken with nothing moving or coming apart.

Ejections will leave a black, gritty residue inside the airframe. Occasionally wipe the tube interior with a damp cloth wrapped around a dowel or broomstick; allow to dry.

See our website FAQ for information about thrust rings and motor retention. Motor recommendation information is available on our website on the Specs Page.

For our complete FAQ, see the FAQ Page on our website at www.publicmissiles.com.

www.publicmissiles.com

The PML Web Store and Knowledge Base

Other items you will need:

One set of epoxy
One set finishing epoxy
One sheet each 120 and 220 sandpaper

Ruler and pencil
Masking tape
Cellophane tape

**Please read and understand all instructions before continuing!
All surfaces to be bonded must be scuffed with 120 grit sandpaper.**

Step 1

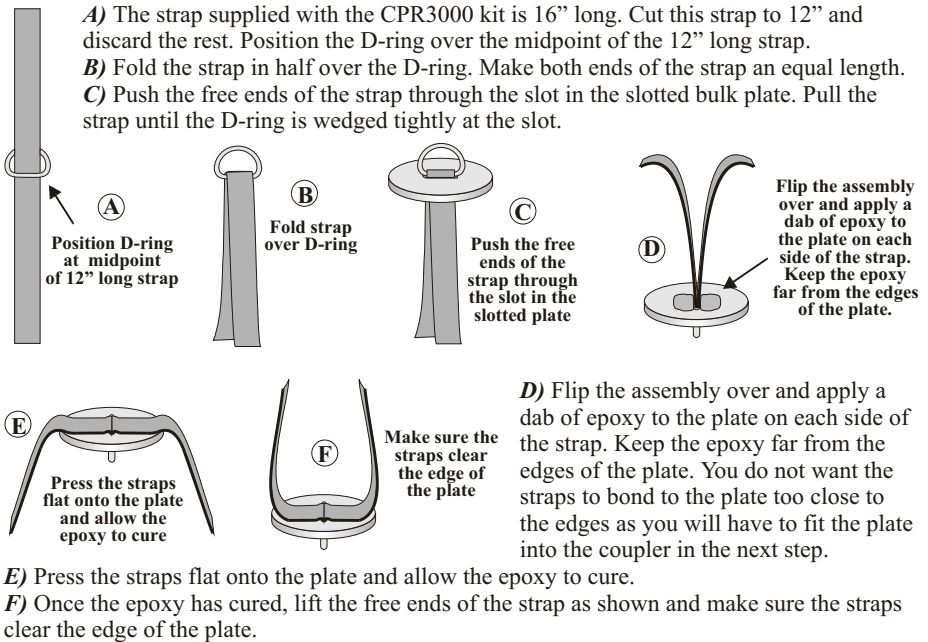

D) Flip the assembly over and apply a dab of epoxy to the plate on each side of the strap. You do not want the straps to bond to the plate too close to the edges as you will have to fit the plate into the coupler in the next step.

Step 2

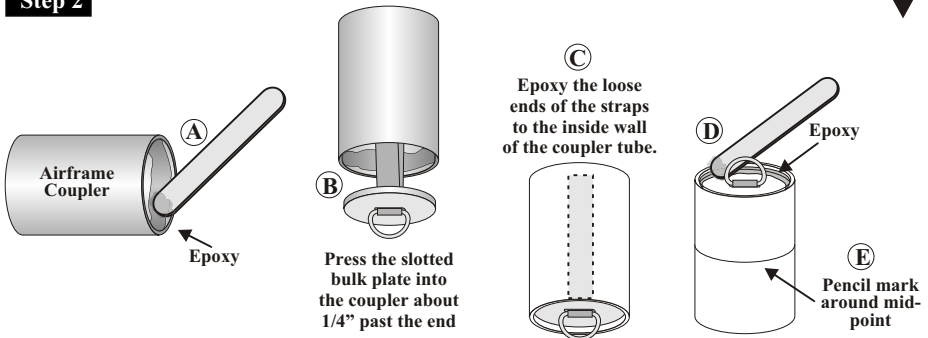

A) Spread a bead of epoxy around the inside circumference of one end of the coupler tube.

B) Press the slotted bulk plate into the coupler about 1/4" past the end. Allow the epoxy to cure.

C) Epoxy the loose ends of the straps to the inside wall of the coupler tube.

D) Flip the assembly over and add an epoxy fillet to the other side of the bulk plate.

E) Draw a pencil mark around the mid-point of the coupler tube.

Step 3

A) Apply a bead of epoxy to the root edge of a fin. Set the fin into the dado slot in the airframe. Make sure that the fin is perpendicular to the airframe. Use tape to hold the fin in position while the epoxy cures. Repeat this process for all fins.

B) Apply an epoxy fillet to both sides of each fin. Carefully smooth the epoxy with your finger before it begins to gel. Allow the epoxy to set up before rotating the rocket to do the next set of fins. Once the epoxy has fully cured, you should sand the fillet smooth with fine sandpaper.

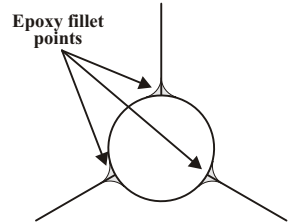
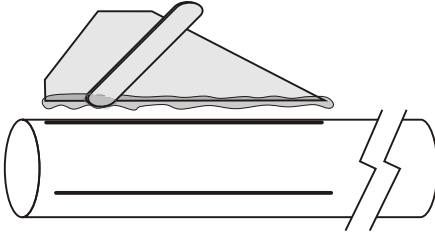

Step 4

Sand the area of airframe between the fins, the fillets, and the fins using 120 grit sandpaper.

Draw a pencil mark on each side of each fin parallel to the root and 1" from the root.

Mix about two ounces of 20 minute finishing epoxy in a small cup. With a disposable brush, paint the area between the lines with the epoxy. Carefully remove a piece of glass cloth from the package and lay it over the wet area as shown. Allow the cloth to extend above and below the fins. With the brush, use a dabbing motion to press the cloth into the epoxy. Continue until the cloth is properly positioned and there is no air trapped under the cloth. You will notice the cloth becomes clear as the epoxy soaks in. If any area of the cloth is not fully wetted out, dip the brush in the epoxy then dab the dry area again.

Repeat this step for all three sides. When the epoxy "gels" (still flexible and not fully cured), trim the cloth along the edges of the fins with an X-Acto knife.

Allow to fully cure overnight. Again sand the entire area with 120 grit sandpaper to remove any bumps and smooth the edges. Paint the entire area with finishing epoxy to fill any pinholes and imperfections. Allow to cure.

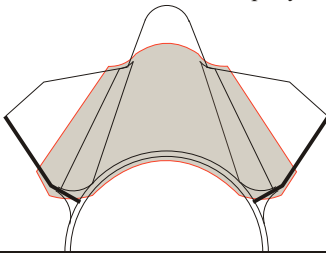

Step 5

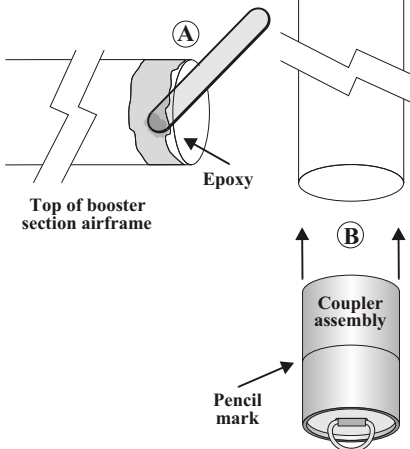

A) Spread a layer of epoxy around the inside circumference of the booster airframe.

B) With the booster airframe held upside down, slowly and with a twisting motion, push the coupler into the airframe up to the pencil mark. This method will keep epoxy from running down into the motor area of the airframe. Keep the assembly inverted until the epoxy cures.

Step 6

Important note:

This step must be completed without interruption before the epoxy sets.

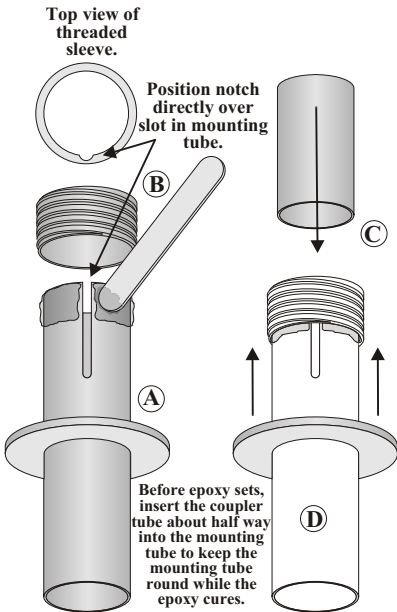

A) Slide the standard centering ring over the slotted mounting tube to the area below the slot.

B) Spread a layer of epoxy around the slotted end of the tube. Keep the epoxy away from the slot. Slip the threaded sleeve over the tube making sure the small notch in the top of the threaded sleeve is aligned over the slot in the tube.

C) Push the coupler tube half way into the slotted end of the mounting tube to keep the tube round and firmly against the ID of the threaded sleeve. **Do not glue this tube in place!**

D) Slide the centering ring up the tube and against the base of the threaded sleeve. Wipe away any excess epoxy from the bottom of the threaded sleeve and centering joint. Excess epoxy here can interfere with the proper fit of the upper threaded coupler when the CPR system is complete and assembled. Allow the epoxy to cure.

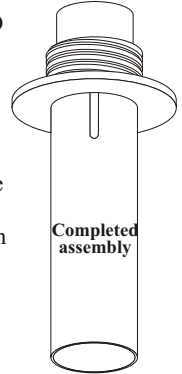

Step 7

A) Spread a layer of epoxy around the circumference of the opposite end of the tube about 1/4" from the end. Leave a 1" gap in the epoxy **not in line with the slot**. Push the notched centering ring onto the tube with the notch aligned with the gap in the epoxy. Position the ring 1/2" from the bottom. Allow the epoxy to cure.

B) Remove the coupler tube from the mounting tube and discard it.

C) Turn the assembly over and apply an epoxy fillet to both centering rings. Keep the notches and slots free of epoxy

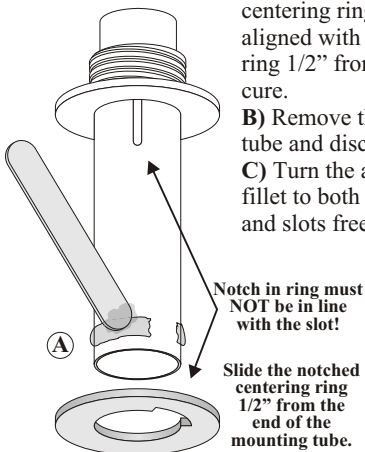

B) Remove the coupler tube.

Turn the assembly over and apply an epoxy fillet to both centering rings.

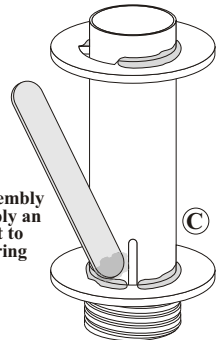

Step 8

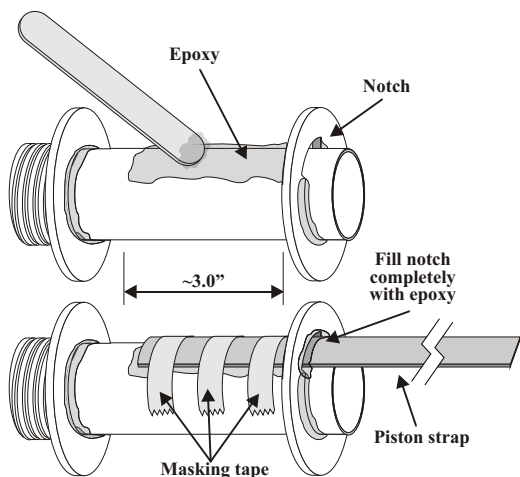

Spread a layer of epoxy about 1" wide and 3" long on the mounting tube just below the notch in the centering ring. Slip one end of the piston strap (one of the wide, 60" long straps) through the notch in the centering ring. Pull through about 3" of this strap through the notch and press it firmly into the epoxy on the side of the mounting tube. Hold the strap in place against the tube with masking tape until the epoxy cures. Remove the masking tape. **Fill the entire centering ring notch with epoxy.** Stuff the free end of the strap into the tube to keep it out of the way for the next step.

Step 9

- Slide the standard centering ring over the 4" long mounting tube.
- Spread a layer of epoxy around one end of the tube. Slip the threaded airframe coupler over the tube. Make sure the threaded coupler is fully seated on the tube.
- Slide the centering ring up the tube and against the base of the threaded airframe coupler. Allow the epoxy to cure.

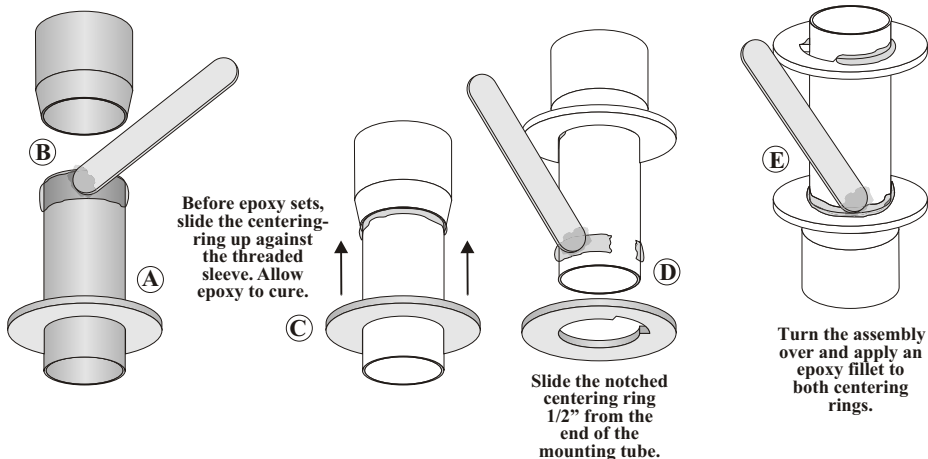

- Spread a layer of epoxy around the circumference of the opposite end of the tube about 1/4" from the end. Leave a 1" gap in the epoxy. Push the notched centering ring onto the tube with the notch aligned with the gap in the epoxy. Position the ring 1/2" from the bottom. Allow the epoxy to cure.
- Turn the assembly over and apply an epoxy fillet to both centering rings. Keep the notch free of epoxy.

Step 10

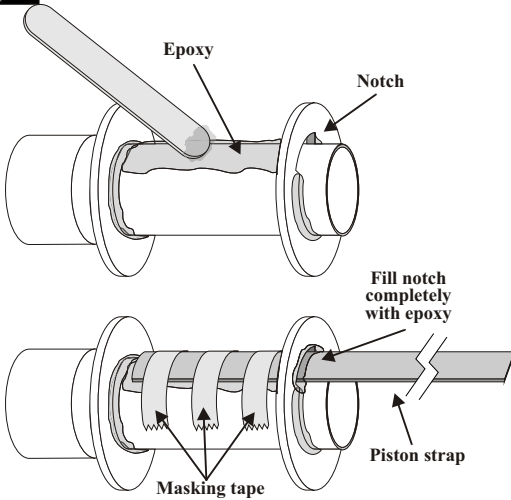

Spread a layer of epoxy about 1" wide on the mounting tube just below the notch in the centering ring. Slip one end of the piston strap (the second of two 60" long straps) through the notch in the centering ring. Pull through about 2-1/4" of this strap through the notch and press it firmly into the epoxy on the side of the mounting tube. Hold the strap in place against the tube with masking tape until the epoxy cures. Remove the masking tape. **Fill the entire centering ring notch with epoxy.** Stuff the free end of the strap into the tube to keep it out of the way for the next

Step 11

You will need a long stick or dowel for applying epoxy in this step. Just below is a drawing of one good method for creating an extended epoxy applicator. Simply epoxy a dowel or stick to a tongue depressor or popsicle stick.

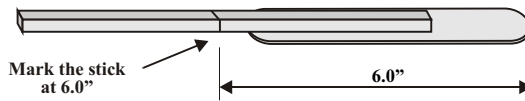

A) Make a mark on the stick at 6.0" so you can tell how deep the stick is in the airframe when spreading the epoxy. Using your extended epoxy applicator, spread a bead of epoxy around the inside circumference of the airframe 6.0" from the bottom of the airframe.

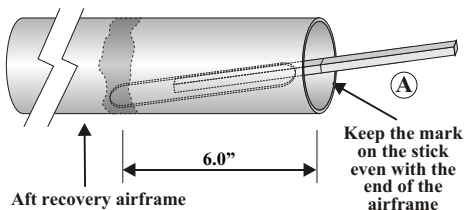

B) Push the altimeter mounting tube assembly about 2" into the aft recovery airframe. Spread another bead around the inside circumference about 1/2" from the end of the airframe. You can push the assembly from one side to the other to make it easier to reach with the epoxy applicator.

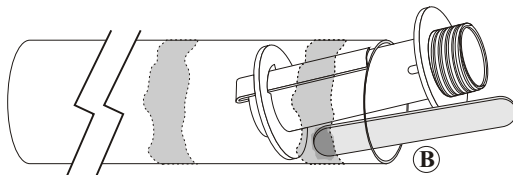

C) Holding the aft recovery airframe upright (vertical), push the altimeter tube assembly the rest of the way into the airframe until the bottom of the threaded sleeve is flush with the bottom of the airframe. Keep the assembly vertical until the epoxy cures.

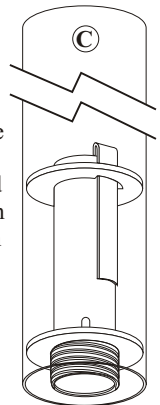

↑
Threaded sleeve flush with airframe

Step 12

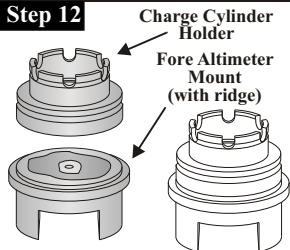

Epoxy one of the Charge Cylinder Holders to the fore altimeter mount and the other to the aft altimeter mount. Make sure the mounts and holders are centered with one another as closely as possible. Prevent epoxy from filling the holes in the center of each piece.

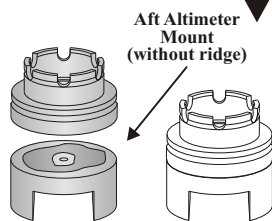

Step 13

- A) Roll the 1-1/2" O-ring onto the fore altimeter mount as shown.
- B) Place the fore altimeter mount assembly into the altimeter mounting tube.
- C) Slip the 1-7/8" long airframe coupler into position.
- D) Roll the largest of the O-rings over the coupler down to the airframe.

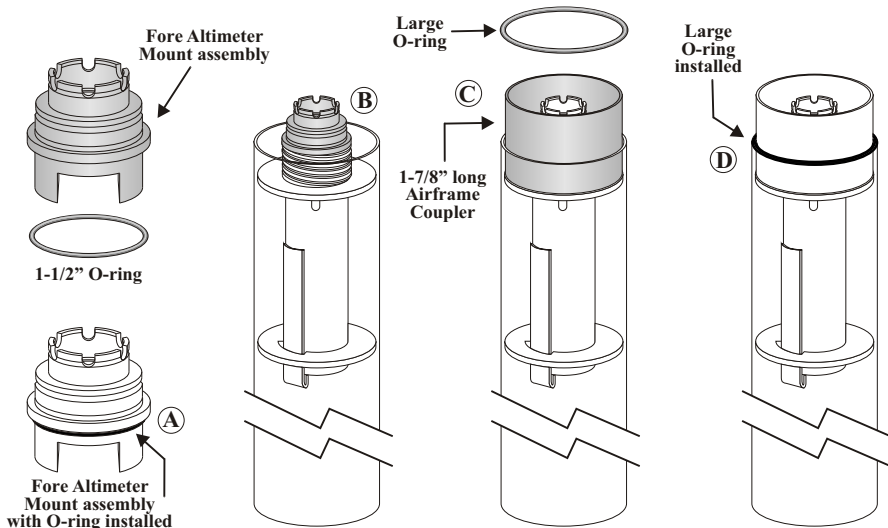

Step 14

Thread the threaded airframe coupler assembly onto the altimeter mounting tube assembly just until you feel the resistance of the threaded airframe coupler contacting the fore altimeter mount. Do not tighten at this time.

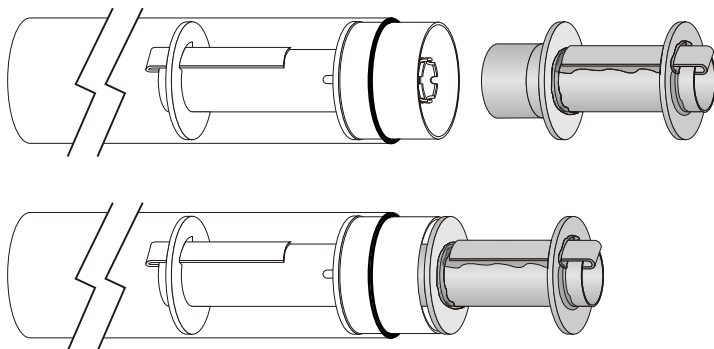

Step 15

A) Make a mark on the stick at 3.0" so you can tell how deep the stick is in the airframe when spreading the epoxy. Using your extended epoxy applicator, spread a bead of epoxy around the inside circumference of the airframe 3.0" from the bottom of the airframe.

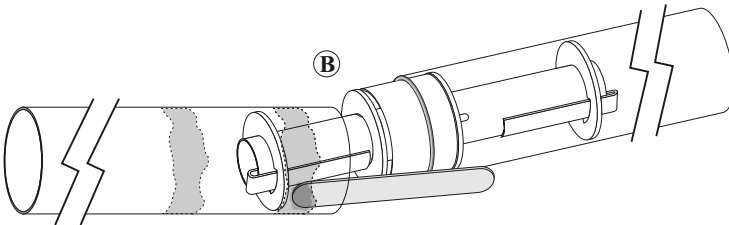
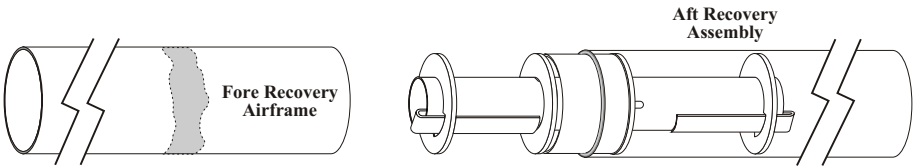
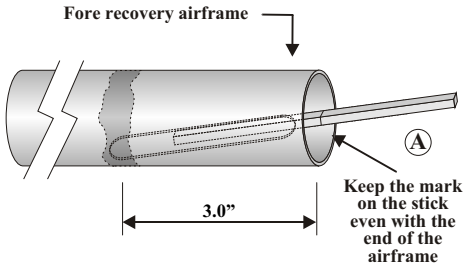

B) Push the altimeter mounting tube assembly about 2" into the aft recovery airframe. Spread another bead around the inside circumference about 1" from the end of the airframe. You can push the assembly from one side to the other to make it easier to reach with the epoxy applicator.

C) Holding the aft recovery airframe upright (vertical), push the fore recovery airframe the rest of the way over the assembly until the airframe is in full contact with the exterior O-ring. Give it a little extra push to assure full contact. Do not turn either airframe to tighten or loosen the threads. Keep the assembly vertical until the epoxy cures. Unscrew the two airframes. The airframe coupler may have bonded to the fore airframe. If it has, that's fine. If not, it can remain loose and does not need to be bonded.

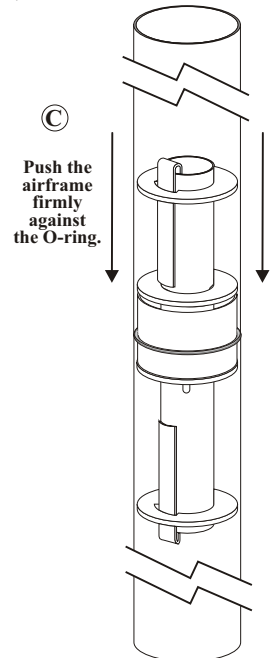

Step 16

NOTE: In this step you will be using the free end of the straps that you mounted to the fore and aft recovery assemblies.

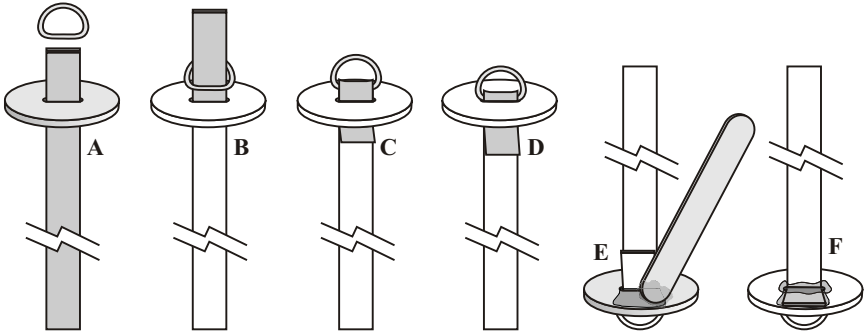

A) Pull the free end of the strap through the slot in the piston bulk plate.

B) Slip the metal "D" ring over the strap.

C) Feed the strap back through the slot.

D) Pull on the strap until the "D" ring is wedged at the slot.

E) Flip the assembly over. Spread a layer of epoxy on the underside of the piston plate as shown. Fold the short end of the strap flat against the piston plate and press it into the epoxy. You can use a clamp to hold the strap in the epoxy while it sets.

F) When the epoxy has cured, pull the strap until the "D" ring is wedged tight at the slot. Apply epoxy to the strap at the "D" ring.

G) Epoxy the piston plate inside the piston body 1/8" from the top.

H) Apply an epoxy fillet to both sides of the piston plate.

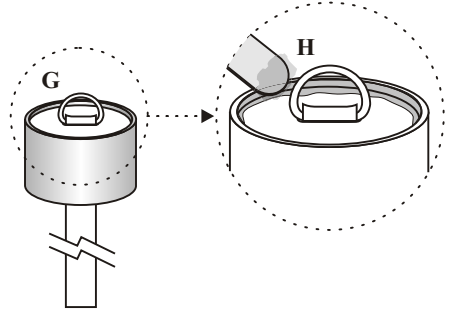

Repeat this entire step to assemble the other piston

Step 17

The Fore and Aft Altimeter Mounts used in the CPR-3000 system are designed around the PML Co-Pilot Altimeter and the Transolve P6 Altimeter. Mounts for the Transolve P5 and ALTS-25 are available as optional items through PML. Other units may work as well with slight modifications to the mounts. Modifications may require relocating the mounting holes and grinding away material for clearances. Be careful not to weaken the mounts. Consult the altimeter manufacturer for their recommendations.

A) Mount the altimeter to the fore and aft altimeter mounts using the 4 Socket Head Screws and wrench supplied with this kit. Do not over-tighten the screws to prevent stripping the mounts.

B) Install the smallest (1-3/8") O-ring in the groove of the Aft Charge Cylinder Holder. The second smallest (1-1/2") O-ring should already be installed against the ridge of the Fore Altimeter Mount from a previous step.

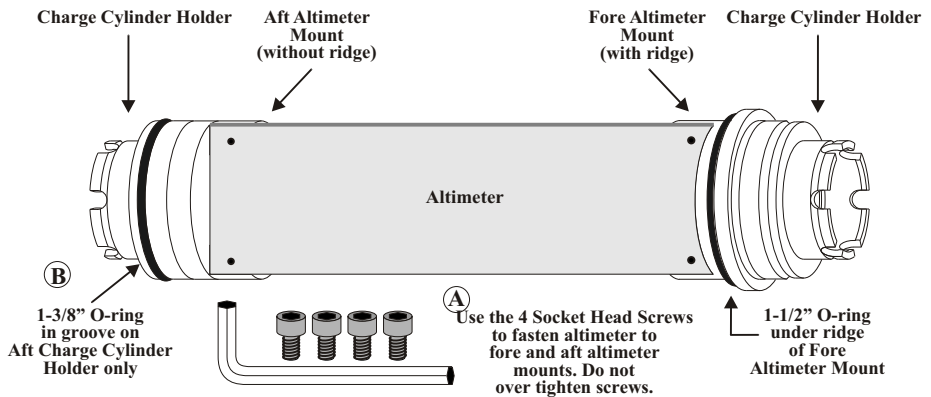

Step 18

In order to properly install the safety switch, you will need to cut a 1/2" x 1/4" opening into the airframe as indicated in the drawing below. **This switch opening must be aligned with the slot in the internal altimeter mounting tube.** First mark out the perimeter of the opening on the airframe, then drill a series of small holes within the marks, starting near the corners, and removing the remaining material with a pointed X-Acto knife. Test fit the switch into the hole to assure a good fit.

Drill a 1/8" hole in the airframe opposite of the safety switch and 5" from the top of the airframe. This hole is for venting the altimeter to the atmosphere.

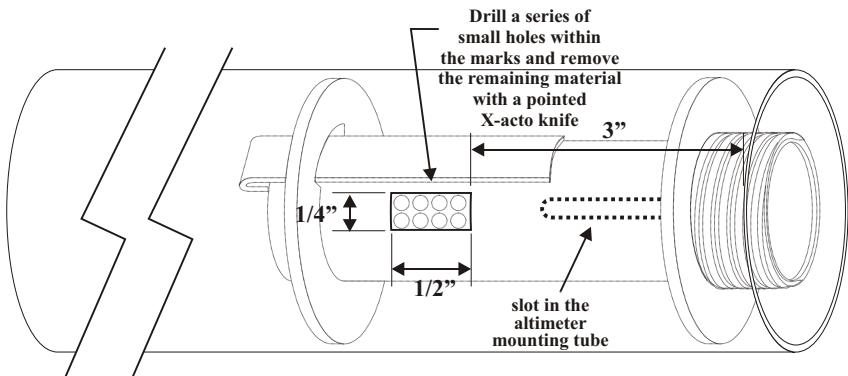

Step 19

Note:

This step is only required for the CPR-3000-2.1 kit. The Switch Stand-Off mentioned in this step is not needed and not provided with larger CPR-3000 kits. For all other kits, skip to the next step.

The switch Stand-Off is necessary to create the clearance needed between the altimeter mounting tube and the exterior of the 2.1" airframe for the lugs and wires on the back of the switch. The backside of the stand-off must be contoured to properly fit the 2.1" airframe you are using.

Simply drape a piece of medium sandpaper over the airframe and hold it in place with one hand. Holding the stand-off with your other hand, move the stand-off back and forth along the sandpaper until the back of the stand-off has the desired contour.

Use CA (super glue) to glue the stand-off over the switch hole you created in the previous step.

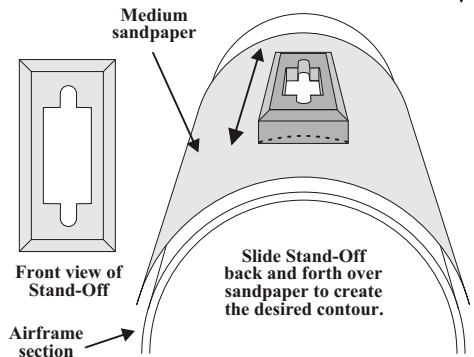

Step 20

Solder one safety switch wire to the center terminal of the switch and the other wire to one of the outside terminals of the switch. Since space between the altimeter tube and the airframe is limited, solder the wires to the terminals from the side as shown in the bottom view below. Polarity does not matter in this application. This switch has two positions; ON-ON, meaning the switch is able to make connections in both positions. Since you are using only two wires (center terminal and one end terminal), the switch position toward the unwired terminal is "off". Moving the switch toward the wired terminal is "on". Be sure to mount the switch into the rocket with the two wired terminals furthest away from the threaded sleeve end of the airframe. In this configuration, "down" will be "on" and "up" will be "off". Mark the airframe for the on-off positions.

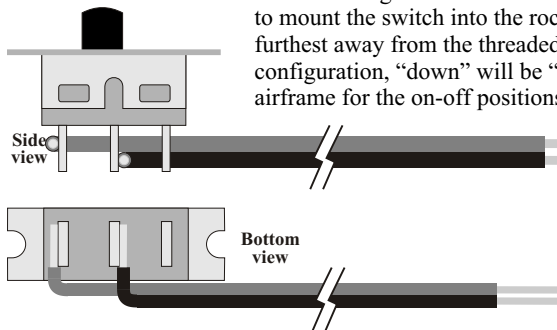

Strip about 1/4" of the insulation from the two wires and "tin" the exposed wires with a bit of solder to stiffen them. These wires will be attached to the power terminals of the altimeter.

Step 21

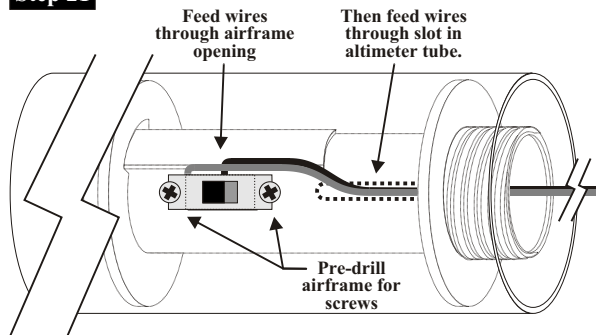

Feed the wire ends into the airframe opening, then through the slot in the altimeter tube and finally out through the end of the altimeter tube. Set the switch into the airframe hole (or stand-off), pre-drill the airframe for the mounting screws, and install the screws. Mark the airframe near the switch for the on-off positions.

The rocket drawn below is generic and may not represent the kit you are building. It is intended to provide a general guideline for mounting launch lugs to this or any PML CPR based rocket.

Sand the entire surface of each launch lug with 100 or 120 grit sandpaper.

The launch lugs must not obstruct or even be near the altimeter vent hole. In fact, the lugs should be mounted on the opposite side of the airframe near but not in direct line with the altimeter power switch.

Epoxy one launch lug in place 1 to 2 inches from the bottom of the rocket and the other launch lug at about the CG (balancing point) of the rocket (without motor installed). If the rocket you are building has a tail cone or boat tail, then mount the first lug just above it. Placement of the lugs is not critical and can be adjusted an inch or so up or down the airframe if necessary. Just be sure the lugs are perfectly in line with each other, parallel to the airframe and not in line with a fin or the altimeter power switch. Apply an epoxy fillet to both sides of each lug. Since with all PML CPR based rocket kits the tail section can be rotated in relation to the aft recovery airframe, be sure both lugs are perfectly aligned when placing the rocket on the launch rod to prevent binding.

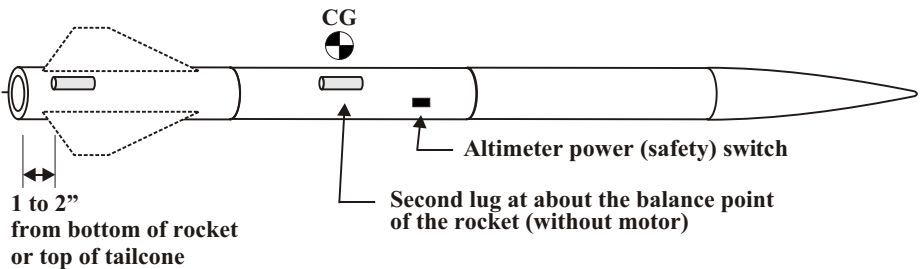

Flight Prep

Congratulations! You have completed the assembly process of the CPR-3000 based Nimbus rocket kit.

The remainder of this booklet is designed to show you how to prep your CPR-3000 based rocket for flight. Please follow the instructions in the order they are written.

When prepping and packing the parachutes, refer to the chute instructions that are packed with each chute.

Instructions for using your particular altimeter, as well as connecting charges and safety switches should have been included with your altimeter. If these instructions are missing or vague, consult your altimeter manufacturer before proceeding.

Step A

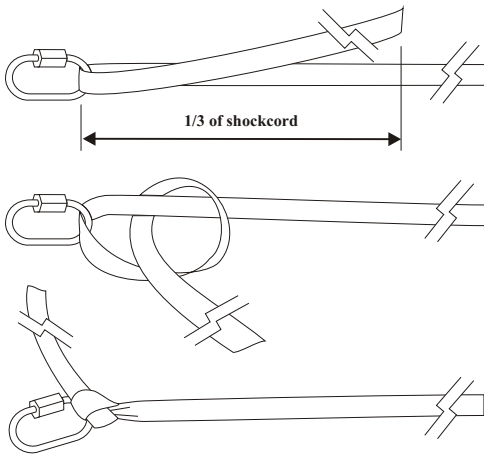

Thread the shock cord through the Kwik-Link and tie it using the knot illustrated on the left. Note that the Kwik-Link should be attached to the shock cord at about the 1/3 point of the shock cord.

Step B

Thread the long end (the 2/3 section) of the shock cord through the "D" ring and tie it using the knot illustrated below. Alternatively, you can tie the shock cord to a "kwik-link" and then attach the "kwik-link" to the "D" ring. Use the same knot to attach the other end of the shock cord to the eye bolt on the payload section.

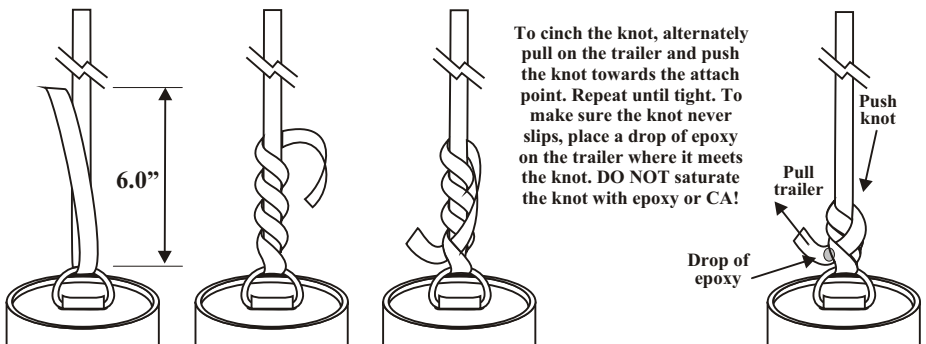

Step C

Using a sharp pointed knife, remove the flash from the eyelet at the base of the nosecone. If necessary, you can enlarge the eyelet by using the knife to extend the opening toward the nosecone body (not toward the edges as this will weaken the eyelet). Thread the shock cord through the eyelet and tie it to the nosecone using the knot illustrated below. Add a drop of epoxy to the trailer at the knot to make sure the knot never slips. **DO NOT** saturate the knot with epoxy or CA. Alternatively, you can tie the shock cord to a “kwik-link” and then attach the “kwik-link” to the nosecone eyelet.

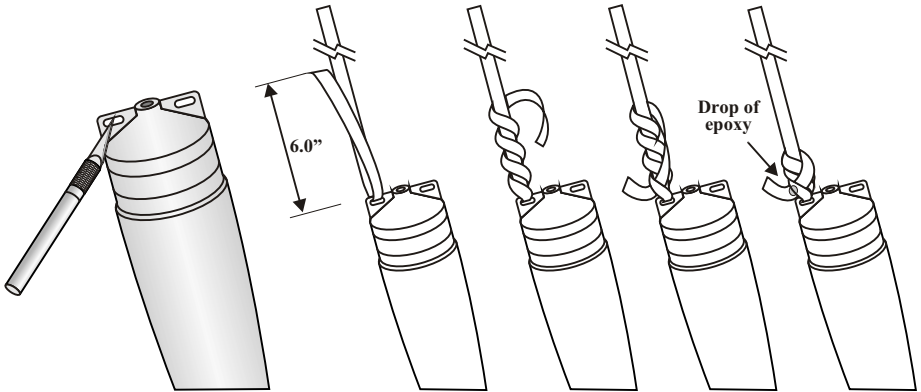

Step D

Below is a diagram illustrating the various shock cord and parachute attachment points.

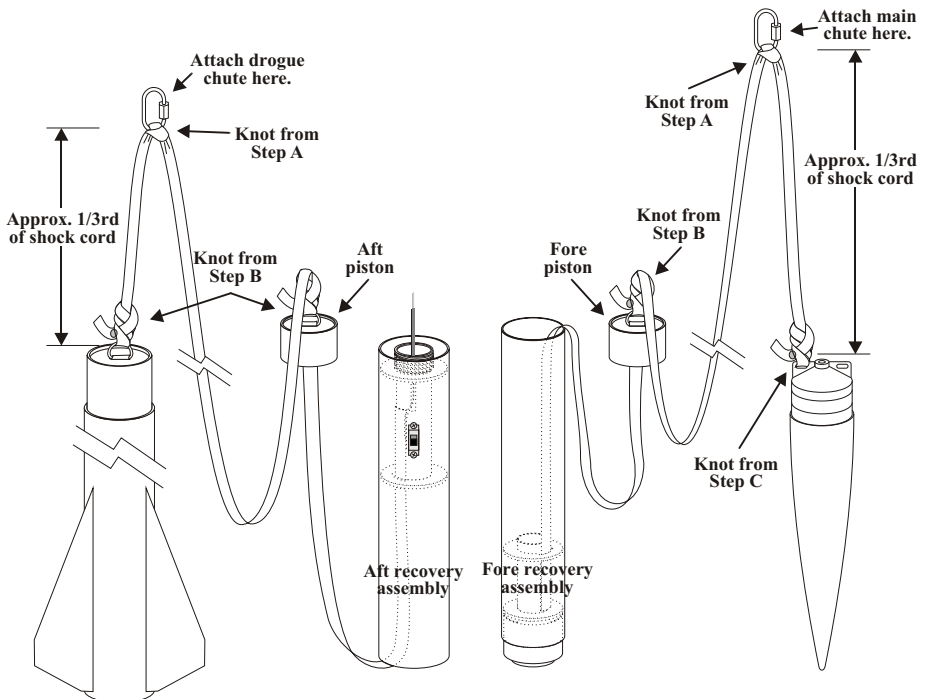

Step E

Push the Fore Piston into the Fore Recovery Airframe as far as it will go without forcing it. Pack the main chute as directed in the parachute packing instructions. Fit the nosecone to the Fore Recovery airframe. The nosecone should fit **tight** (you should be able to lift the entire assembled rocket by the nosecone without it slipping off). Apply masking tape to the nosecone shoulder to make the fit tighter if necessary. Double-check this fit once the rocket is fully assembled.



Push the Aft Piston into the Aft Recovery Airframe as far as it will go without forcing it. Pack the drogue chute as directed in the parachute (or streamer) packing instructions. Fit the fin unit to the Aft Recovery Airframe. The fin unit should fit **snug**, but not tight. Lift this assembly by the Aft Recovery Airframe and shake lightly. The fin unit should just begin to slip off the recovery airframe.

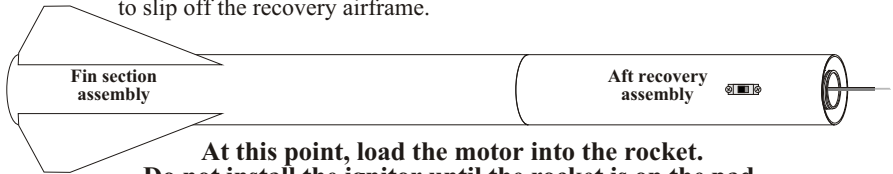

**At this point, load the motor into the rocket.
Do not install the ignitor until the rocket is on the pad.**

Step F

Be safe...

From this point on, wear safety glasses while prepping your altimeter for flight!

NOTE: Charge Cylinders for use with flash bulbs are available as an option through PML.

- A)** The electric match is inserted into this hole and is held horizontal and centered by the internal geometry of the Charge Cylinder.
- B)** The lead is then bent over toward the bottom of the cylinder following the groove.
- C)** Push a small wad of tissue into the hole using a pointed object. This will seal the hole and keep the black powder from leaking out.
- D)** The lead is then threaded into the hole in the bottom center of the Holder and finally through the altimeter mount.
- E)** Push down to snap the Charge Cylinder into the Holder.

This routing method creates a labyrinth that the gasses cannot follow to the altimeter bay. Follow the instructions supplied with your altimeter for connecting the electric match to the altimeter.

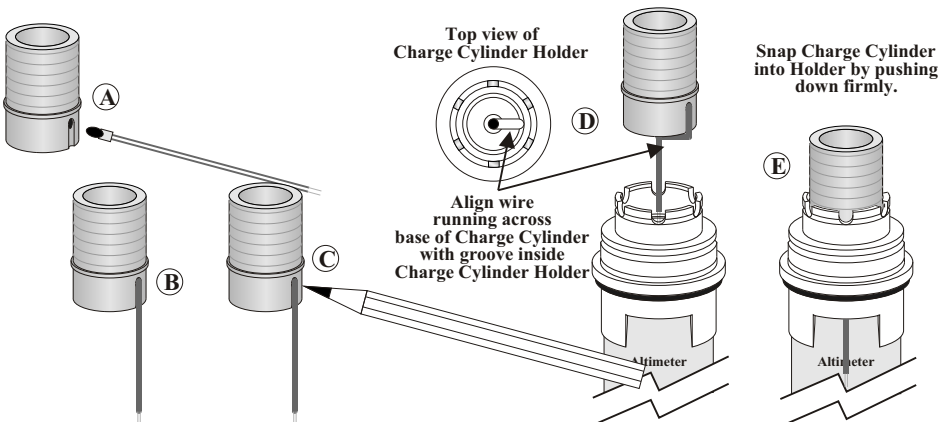

- E) Determine the correct amount of FFFFg Black Powder to use for proper ejection using the chart below. Measure-out the Black Powder and pour it into the Charge Cylinder.
 F) Fill the remainder of the Charge Cylinder with a crumpled piece of flame-proof wadding to keep the Black Powder from moving about.
 G) Place the orange vinyl cap over the Charge Cylinder.

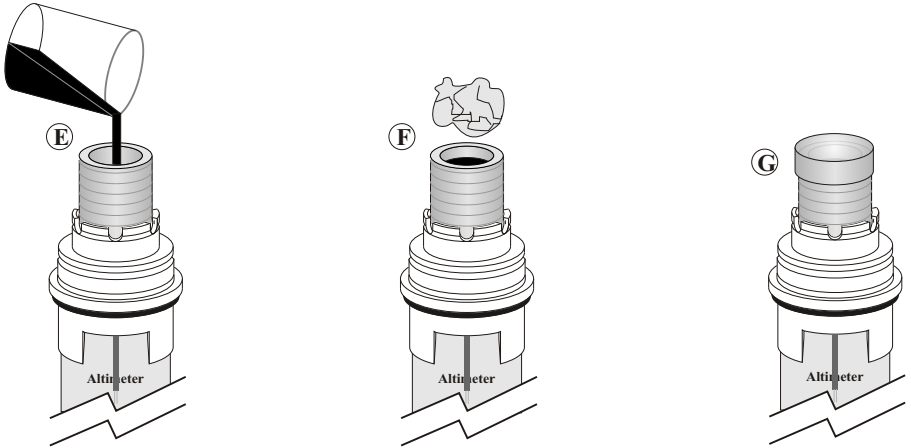

Repeat this step for prepping the Aft Charge Cylinder:

The chart below is intended as a guide for determining the proper amount of ejection powder used with various diameter CPR-3000 rockets using a piston ejection system and an 18" fore or aft recovery airframe.

2.1" dia.	0.2 to 0.3 grams
2.5" dia.	0.3 to 0.4 grams
3.0" dia.	0.4 to 0.5 grams
3.9" dia.	0.5 to 0.6 grams

Step G

"Lubricate" the inside of the altimeter tube using Talcum Powder. This will allow the O-ring on the aft Charge Cylinder Holder to travel smoothly within the tube. Move the Safety Switch wires into the groove at the top of the Threaded Sleeve. This will allow the Aft Charge Cylinder Holder and Aft Altimeter Mount to slip into the Altimeter Tube. Double check that the electric matches are connected to the proper terminals.

Make absolutely sure the Safety Switch is in the OFF position! Begin slipping the altimeter assembly into the Altimeter Tube (aft end first), but stop while the safety switch terminals on the altimeter are still exposed. Attach the Safety Switch wires to the terminals on the altimeter. Continue to push the altimeter assembly into the Altimeter Tube (make sure the safety switch wires are not binding on anything) until the O-ring on the Fore Altimeter Mount is in contact with the Threaded Sleeve.

Make sure switch is in "OFF" position.

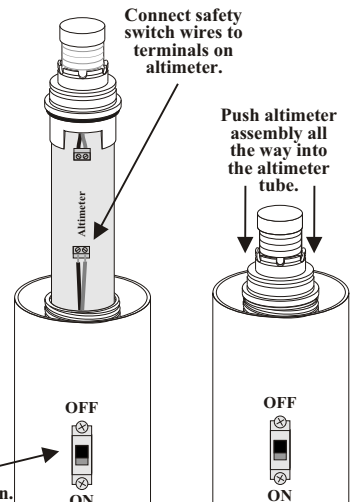

Step H

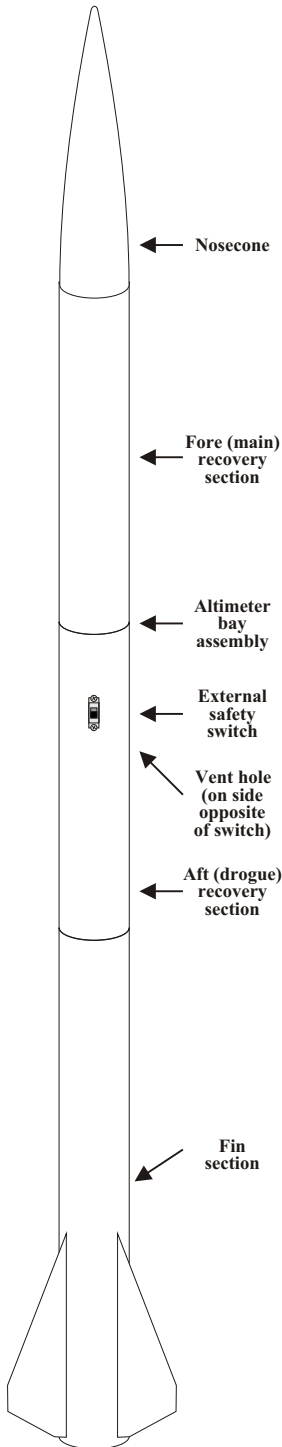

Screw the Fore section of the rocket to the Aft section. Once contact is made between the Fore and Aft sections, give the airframes a little extra turn to snug everything up.

Place the rocket on the launch pad. Install the ignitor into the motor and attach the ignitor leads to the launch controller. Check the launch controller for continuity. Keeping your head away from the rocket, set the safety switch to the "ON" position. Listen (or look for) the altimeter tones or lights to assure the unit is armed and functioning properly. The rocket is now ready for launch.

CPR-3000 system check list:

At the flight prep area...

Make sure all shock cords and parachutes are attached correctly.

Pack the aft recovery system.

Slip the fin section into the aft recovery section.

Pack the Fore recovery system.

Fit the nosecone onto the fore recovery section.

Inspect the 1/8" vent hole opposite the safety switch. Make sure it has no burrs and is free of obstructions.

Install the motor into the rocket.

Insert a fresh battery into the altimeter.

Make sure both O-rings are in place.

Load and connect both ejection charges.

Set the external safety switch to the "OFF" position.

Partially insert altimeter assembly into the altimeter tube.

Connect the safety switch wires to the altimeter.

Finish installing the altimeter assembly into the altimeter tube.

Make sure the large O-ring is in place around the airframe coupler

Screw the fore recovery section to the aft recovery section.

Check nosecone for tight fit (you should be able to lift the entire rocket by the nosecone without it slipping off).

At the launch pad...

Place the rocket on the launch rod.

Install the ignitor into the motor.

Connect ignitor to the launch controller.

Check for continuity.

Set the altimeter safety switch to the "ON" position.

Listen for the altimeter tones to assure the unit is armed and

www.publicmissiles.com

The PML Web Store and Knowledge Base



www.publicmissiles.com

The PML Web Store and Knowledge Base