

MIDGET™

2 Stage Rocket

CLASSIC DESIGN

FUN TO BUILD & FLY

BALSA NOSE CONE & FINS

*Design by
Bill Simon*



FLYING MODEL
ROCKET KIT



SEMROC

Made in the U.S.A by Semroc Astronautics Corporation - Knightdale, N.C. 27545

Midget™ Kit No. KV-68

Specifications	Engine	Approx. Altitude
Body Diameter 0.976" (2.5 cm)	A10-0T, 1/2A3-4T	550'
Length 9.2" (23.4 cm)	A10-0T, A3-4T	800'
Fin Span 5.6" (14.2 cm)		
Net Weight 1.0 oz. (28.4 g)		

STREAMER RECOVERY

About the Midget™

The Astron Midget was released by Estes Industries in the late 1968 catalog. It was designed by Bill Simon in 1968 when he was Vice President of Estes. It was specially designed for the new Series III "Shorty" engines as a small high performance two-stage kit. It was released as Catalog No. 682-K-40 and retailed for \$1.25.

The Retro-Repro™ Midget™ is updated with laser-cut fins. The original parachute is replaced with a bright streamer for easier recovery. The engine mount is replaced with Kevlar thread for better retention. Empty casings the same size as the "Shorties" allows the use of standard "T" mini-engines.

About Estes Industries, Inc.

In July 1958, G. Harry Stine of Model Missiles, Inc. in Denver, Colorado approached Vern Estes about making model rocket engines for them. On January 15, 1959, Vern's automated model rocket engine fabricating machine, "Mabel", produced the first of many millions of Estes model rocket engines. In 1960, Estes was producing more engines than Model Missiles could sell. Vern and his wife Gleda opened a mail order rocket company and introduced the Astron Scout and Astron Mark.

In 1961, a catalog was mimeographed and hand stitched on Gleda's sewing machine. Later that year, Estes Industries had outgrown the confined space in Denver. In December 1961, the entire operation was moved to an old farm in Penrose, Colorado quickly establishing the small town as the "Model Rocket Capital of the World."

Estes Industries was sold to Damon in September 1969. The name Estes is synonymous with model rocketry. Almost everyone remembers growing up firing Estes rockets or knowing someone that did. Estes Industries has introduced millions of youngsters of all ages to model rocketry for over half a century

EXPLODED VIEW

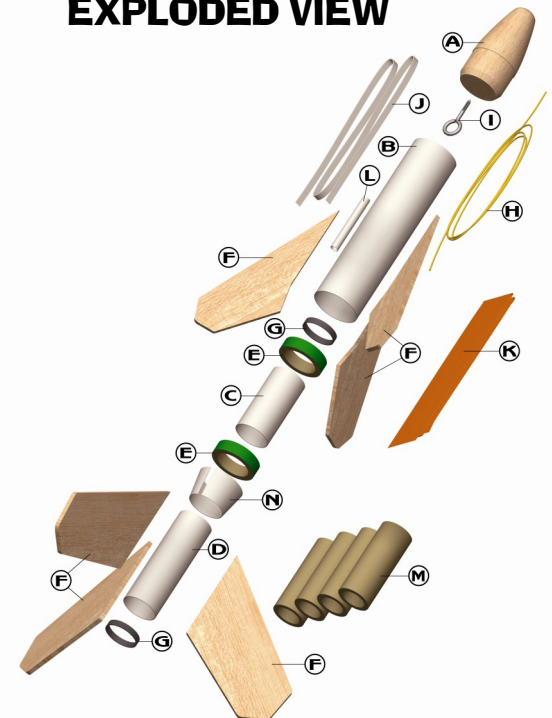

PARTS LIST

A	1	Balsa Nose Cone	BNC-50J
B	1	Body Tube	BT-50S
C	1	Body Tube	BT-20AE
D	1	Body Tube	BT-20M
E	2	Centering Rings	AR-2050
F	1	Laser-cut Fin Set	FV-68
G	2	Engine Blocks	EB-20B
H	1	Kevlar Cord	SCK-12
I	1	Screw Eye	SE-1
J	1	Elastic Cord	EC-112
K	1	Streamer	RS-136
L	1	Launch Lug	LL-122
M	4	Empty Casings	MC-717
N	1	Shroud	IKV-68S
O	1	Decal (Not Shown)	DKV-68

July 18, 2012

Copyright © 2012 Semroc Astronautics Corporation
Box 1271 Knightdale, NC 27545 (919) 266-1977

TOOLS

In addition to the parts supplied, you will need the following tools to assemble and finish this kit. Cellophane tape and masking tape are also required.

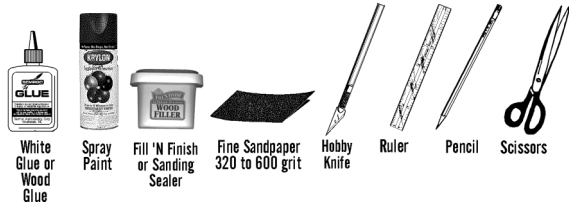

ASSEMBLY

1. These instructions are presented in a logical order to help you put your Midget™ together quickly and efficiently. Check off each step as you complete it and we hope you enjoy putting this kit together.

FIN PREPARATION

2. Lightly sand each side of the laser-cut fin sheet (FV-68). Carefully push the laser-cut fins from their sheet. Start at one point on each fin and slowly and gently work around the fin.

3. Stack all the like fins in sets. Line each set of fins up squarely and sand the fins back and forth over some fine sandpaper to get rid of the hold-in tabs as shown below.

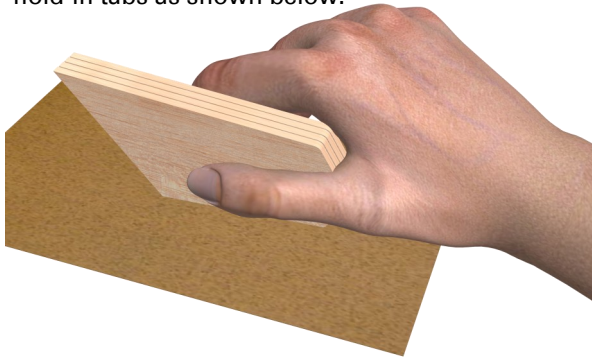

4. Round all the edges of each fin, except the root edges. Leave them flat. Repeat for all eight fins. The root edges will be glued to the body tube.

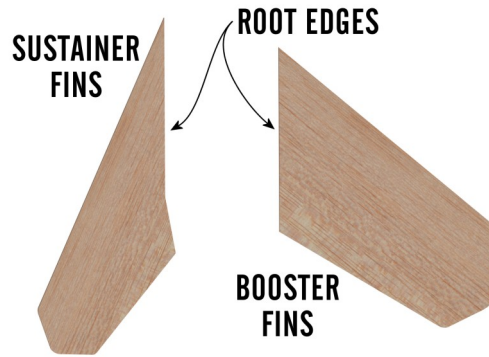

MARK TUBES

5. Stand the large body tube (BT-50S) on the fin guide below on the ring marked BT-50 and make the fin position marks on the sides of the tube. Find a convenient channel or groove such as a partially open drawer, a door jamb (as shown,) or a piece of molding. Using the channel, extend the marks the length of the tube. Stand the second longest tube (BT-20M) on the ring marked BT-20 and mark the booster fin positions on the sides of the tube. Extend those lines the length of the tube as before.

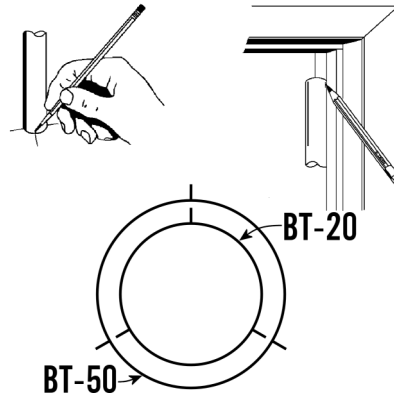

SHROUD

6. Carefully cut out the paper shroud (IKV-68S). Roll the shroud carefully forming it into a cone, being careful to avoid creasing the paper. Apply a thin layer of white glue on the indicated section inside the dotted line. Line up the opposite edge with the dotted line and press together on a flat surface. Hold it in place until the glue sets.

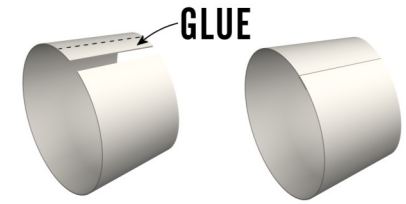

SUSTAINER

7. Tie a small knot in one end of the yellow Kevlar thread (SCK-12). Pass it through one of the centering rings (AR-2050) and slide the ring over the small engine tube (BT-20AE). Align the ring even with the top of the tube and pull the thread until the knot is against the ring. Apply a bead of glue around the bottom of the ring against the engine tube. Keep glue from the outer (green) surface of the ring. Allow to dry.

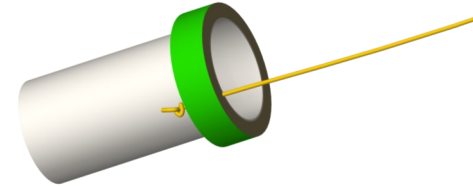

8. Slide the remaining centering ring (AR-2050) until it is exactly 5/8" from the end of the engine tube. Apply a bead of glue around each side against the engine tube. Keep glue from the outer (green) surface of the ring. Allow to dry.

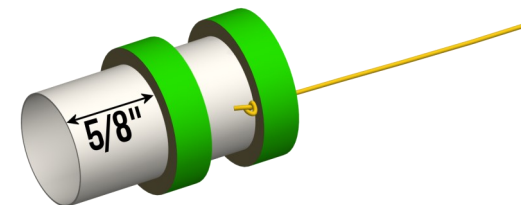

9. Apply a bead of glue on the lower end of the engine tube and around the lower surface of the lower ring just touching the green surface of the ring. Slide the shroud over the end of the engine tube until it touches the centering ring. Clean any excess glue from the green surface.

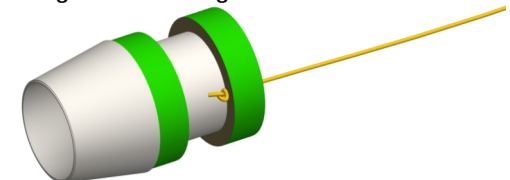

❑ **10.** Apply a bead of glue just inside the top of the engine tube. Insert one of the engine blocks (EB-20B) into the engine tube until it is flush with the end of the tube. Apply a thick bead of glue around the end surfaces of the engine tube, engine block and top centering ring to help protect from hot gasses.

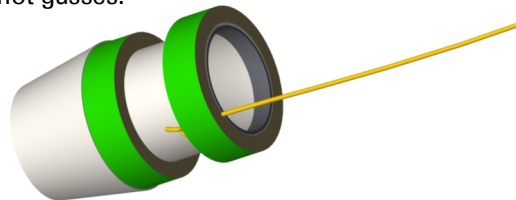

❑ **11.** Apply a heavy bead of glue inside the large sustainer body tube (BT-50S). Pull the yellow Kevlar cord through the top of the engine tube and out the back of the assembly to keep it out of the way. Slide the engine assembly into the sustainer body tube until the shroud is flush with the end of the body tube.

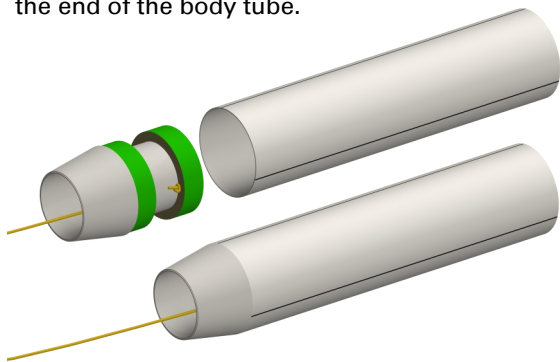

ATTACH FINS

❑ **12.** Apply glue to the root edge of one of the sustainer fins and position it along one of the lines drawn for the fins on the side of the sustainer body tube (BT-50S) and even with the bottom of the shroud. Remove the fin, set it aside and allow it to almost dry, apply additional glue, and reposition. Repeat for the other two fins. If you follow these instructions, the fins will not require much additional work to keep them aligned. Allow the fins to completely dry, checking carefully to make sure they are parallel with the main body tube.

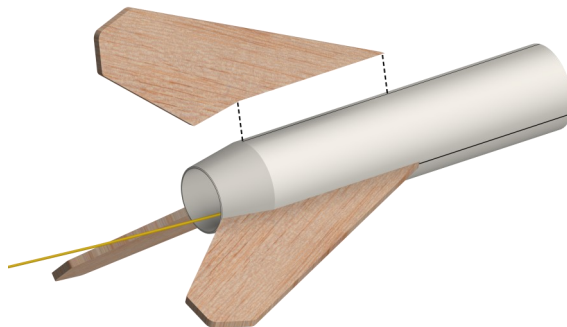

LAUNCH LUG

❑ **13.** Apply a bead of glue to the launch lug (LL-122) and apply it to the main body tube, centered between two fins and even with the bottom of the tube. Sight from one end to make sure it is parallel with the fins.

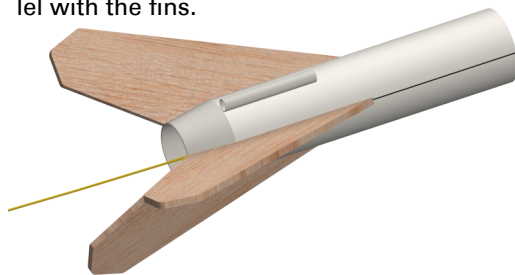

BOOSTER

❑ **14.** Apply a bead of glue to the inside of the bottom 1/8" of the booster body tube (BT-20M). Slide the remaining engine block (EB-20B) in the end of the tube until it is flush. Wipe any excess glue from inside the body tube.

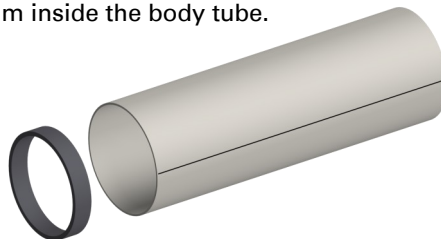

❑ **15.** Apply glue to the root edge of one of the booster fins and position it along one of the lines drawn for the fins on the side of the booster body tube and even with the bottom of the tube. Remove the fin, set it aside and allow it to almost

dry, apply additional glue, and reposition. Repeat for the other two fins. Allow the fins to completely dry, checking carefully to make sure they are parallel with the main body tube.

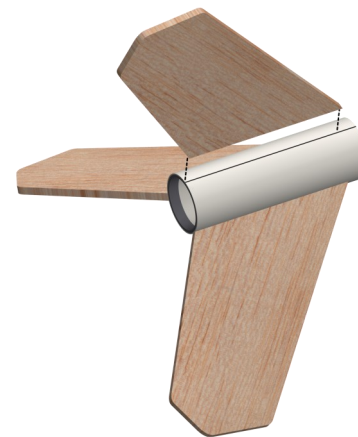

APPLY FILLETS

❑ **16.** After the fins are completely dry, run a small bead of glue along both sides of each fin-body tube joint. Using your forefinger, smooth the glue into fillets. Apply a fillet of glue on each side of the launch lugs. Allow this assembly to dry in a vertical position.

NOSE CONE

❑ **17.** Insert the nose cone (BNC-50J) in the main body tube and check for proper fit. The nose cone should be snug to hold itself in alignment. If it is too loose, add masking tape. If it is too tight, sand the shoulder slightly.

❑ **18.** Screw the screw eye (SE-1) into the base of the nose cone, remove and fill the hole with glue. Reinsert the screw into the nose cone until the eye is flush with the base of the nose cone.

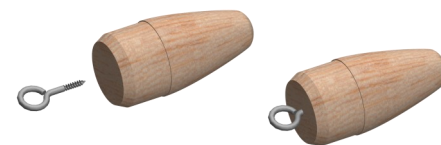

FINAL ASSEMBLY

❑ **19.** Tie the free end of the Kevlar® cord to one end of the elastic cord (EC-112) using an over-hand knot. Pull the elastic cord and Kevlar cord back through the main body tube and out the top of the tube.

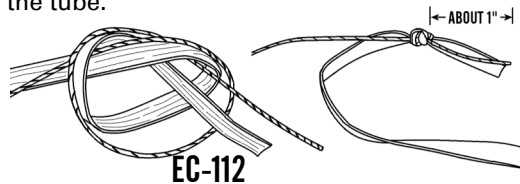

❑ **20.** Attach the free end of the elastic cord to the screw eye. Put a drop of glue on that joint as well. Tie the streamer (RS-136) near its half-way point near the top of the elastic cord.

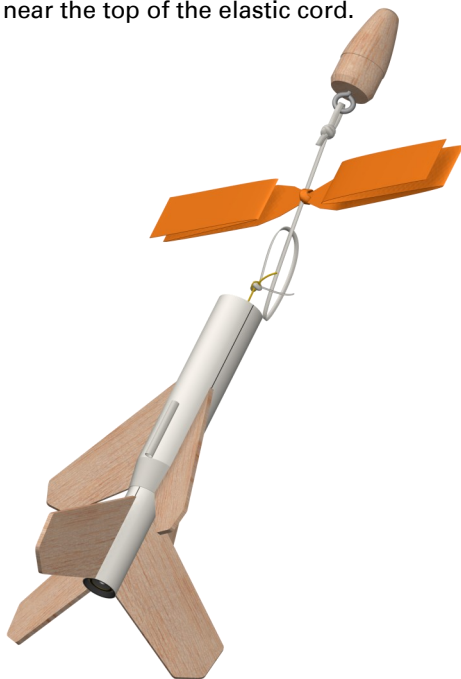

FINISHING

❑ **21.** When the fillets have dried, prepare balsa surfaces for a smooth professional looking finish. Round the edges of the fins, then fill the wood grain with balsa fillercoat or sanding sealer. When dry, sand with fine sandpaper. Repeat until smooth.

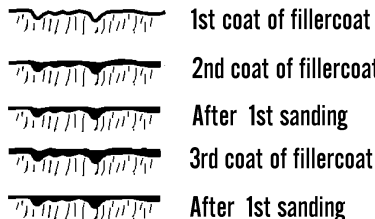

❑ **22.** After all balsa surfaces have been prepared, wipe off all balsa dust with a dry cloth. First spray the model with an enamel primer. Choose high visibility colors like white and blue for the final colors. Spray painting your model with a fast-drying enamel will produce the best results. PATIENCE...is the most important ingredient. Use several thin coats, allowing each coat to completely dry before the next coat. Start each spray a few inches above the model and end a few inches below the model. Keep the can about 12" away and use quick light coats. The final coat can be a little heavier to give the model a glossy wet-looking finish.

❑ **23.** After the paint has dried, decals should be applied. The decals supplied with the Midget™ are waterslide decals. Each decal should be cut separately from the sheet. Use the cover photo for suggested placement. Dip each decal in a small dish of water that has a drop of detergent. It will take about 30 seconds before the decal is loose enough to apply. Slide the decal in place and use the paper backing to work the bubble out. Repeat for all the decals.

FLIGHT PREPPING

❑ **24.** The Midget™ must be flown with "simulated" Shorty engines. Select a booster engine, like A10-0T, for the booster stage. Glue or wedge-fit the engine in one of the empty casings so it is even with both ends of the casing. Mark this one "booster". Select an upper stage engine, like A3-4T, and glue it in one of the empty casings. Mark it "upper stage". Use cellophane tape to attach the booster engine to the upper stage engine. Make sure the nozzle of the booster is at the bottom of the assembly. Add enough masking tape to both engines to make a tight fit in the engine tubes.

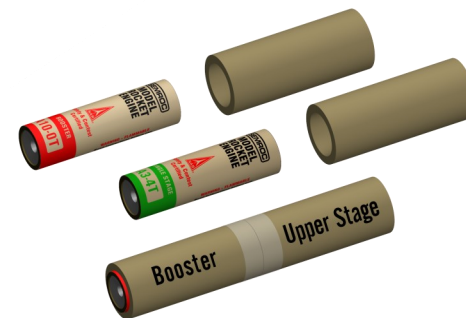

❑ **25.** Insert the "booster" end of the engine assembly into the top of the booster section. Then insert the "upper stage" engine into the bottom of the sustainer section. Apply a few sheets of recovery wadding in the top of the main body tube. Fold the streamer and pack it and the shock cord on top of the recovery wadding. Slide the nose cone into place, making sure it does not pinch the shock cord or streamer.

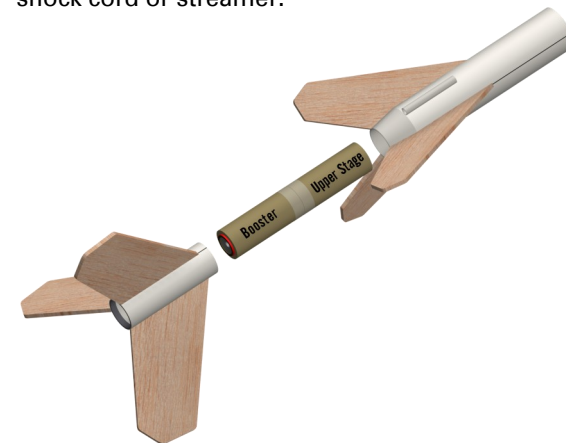

❑ **26.** Refer to the model rocket engine manufacturer's instructions to complete the engine prepping. Different engines have different igniters and methods of hooking them up to the launch controllers.

❑ **27.** Carefully check all parts of your rocket before each flight as a part of your pre-flight checklist. Launch the Midget™ from a 1/8" diameter by 36" long launch rod.

❑ **28.** After each flight, clean any residue from the inside of the tube and make sure the vent hole is clear.