



# Model Rocket Safety Code

- 1. Materials.** I will use only lightweight, non-metal parts for the nose, body, and fins of my rocket.
- 2. Motors.** I will use only certified, commercially-made model rocket motors, and will not tamper with these motors or use them for any purposes except those recommended by the manufacturer.
- 3. Ignition System.** I will launch my rockets with an electrical launch system and electrical motor igniters. My launch system will have a safety interlock in series with the launch switch, and will use a launch switch that returns to the "off" position when released.
- 4. Misfires.** If my rocket does not launch when I press the button of my electrical launch system, I will remove the launcher's safety interlock or disconnect its battery, and will wait 60 seconds after the last launch attempt before allowing anyone to approach the rocket.
- 5. Launch Safety.** I will use a countdown before launch, and will ensure that everyone is paying attention and is a safe distance of at least 15 feet away when I launch rockets with D motors or smaller, and 30 feet when I launch larger rockets. If I am uncertain about the safety or stability of an untested rocket, I will check the stability before flight and will fly it only after warning spectators and clearing them away to a safe distance.
- 6. Launcher.** I will launch my rocket from a launch rod, tower, or rail that is pointed to within 30 degrees of the vertical to ensure that the rocket flies nearly straight up, and I will use a blast deflector to prevent the motor's exhaust from hitting the ground. To prevent accidental eye injury, I will place launchers so that the end of the launch rod is above eye level or will cap the end of the rod when it is not in use.
- 7. Size.** My model rocket will not weigh more than 1,500 grams (53 ounces) at liftoff and will not contain more than 125 grams (4.4 ounces) of propellant or 320 N-sec (71.9 pound-seconds) of total impulse. If my model rocket weighs more than one pound (453 grams) at liftoff or has more than four ounces (113 grams) of propellant, I will check and comply with Federal Aviation Administration regulations before flying.
- 8. Flight Safety.** I will not launch my rocket at targets, into clouds, or near airplanes, and will not put any flammable or explosive payload in my rocket.
- 9. Launch Site.** I will launch my rocket outdoors, in an open area at least as large as shown in the accompanying table, and in safe weather conditions with wind speeds no greater than 20 miles per hour. I will ensure that there is no dry grass close to the launch pad, and that the launch site does not present risk of grass fires.
- 10. Recovery System.** I will use a recovery system such as a streamer or parachute in my rocket so that it returns safely and undamaged and can be flown again, and I will use only flame-resistant or fireproof recovery system wadding in my rocket.
- 11. Recovery Safety.** I will not attempt to recover my rocket from power lines, tall trees, or other dangerous places.

## LAUNCH SITE DIMENSIONS

Installed Total Impulse (N-sec)	Equivalent Motor Type	Minimum Site Dimensions (ft.)
0.00 — 1.25	1/4A	50
1.26 — 2.50	A	100
2.51 — 5.00	B	200
5.01 — 10.00	C	400
10.01 — 20.00	D	500
20.01 — 40.00	E	1000
40.01 — 80.00	F	1000
80.01 — 160.00	G	1000
160.01 — 320.00	2 Gs	1500

**hydra VII™**

1969 AstroRepro

**7 ENGINE POWER!**

**LARGE PAYLOAD SECTION**

**FUTURISTIC DESIGN**

**FLYING MODEL ROCKET KIT**

LASER CUT FINS

MADE IN THE USA

SEMROC

Made in the U.S.A by Semroc Astronautics Corporation - Knightdale, N.C. 27545

## HYDRA VII™ Kit No. KV-29

Specifications	Engine	Approx. Altitude
Body Diameter	C6-3 (1)	250'
Length	C6-5 (3)	950'
Fin Span	C6-7 (7)	1700'
Net Weight		

## PARACHUTE RECOVERY

## What is a Retro-Repro™?

A Retro-Repro™ is a retro reproduction of an out-of-production model rocket kit. It is a close approximation of a full scale model of an early historically significant model rocket kit from one of the many companies that pioneered the hobby over the past half century. A Retro-Repro™ is not a true clone or identical copy of the original. It incorporates improvements using modern technology, while keeping the flavor and build appeal of the early kits.

---

### About Semroc Astronautics Corporation

Semroc Astronautics Corporation was started by Carl McLawhorn in his college dorm at North Carolina State University in November, 1967. Convincing a small group of investors in his home town of Ayden, North Carolina to invest in a small corporation, the company was re-incorporated as Semroc Astronautics Corporation on December 31, 1969.

Semroc produced a full line of model rocket kits and engines. At its peak, Semroc had twenty-five full time employees working at two facilities. One was for research and development, printing, shipping, and administration. The other was outside town and handled all production and model rocket engine manufacturing. For several years, Semroc was successful selling model rocket kits, supplies, and engines by mail-order and in hobby shops. In early 1971, Semroc became insolvent and had to close its doors.

After 31 years of dreams and preparations, Semroc Astronautics Corporation was reincorporated on April 2, 2002 with a strong commitment to helping put the fun back into model rocketry.

---

January 1, 2004

Copyright © 2008 Semroc Astronautics Corporation  
Box 1271 Knightdale, NC 27545 (919) 266-1977

## LIMITATION OF LIABILITY

Model rockets are not toys, but are functional rockets made of lightweight materials and are launched with NAR or Tripoli safety certified model rocket motors, electrically ignited and flown in accordance with the NAR Model Rocket Safety Code. If misused, model rockets can cause serious injury and property damage. Semroc certifies that it has exercised reasonable diligence in the design and manufacture of its products. Semroc cannot assume any liability for the storage, transportation, or usage of its products. Semroc shall not be held responsible for any personal injury or property damage whatsoever arising out of the handling, storage, use, or misuse of our products. The buyer assumes all risks and liabilities therefrom and accepts and uses Semroc products on these conditions.

Your purchase and use of any Semroc products is construed as your agreement to and acceptance of these terms. If you do not agree to these terms and conditions, you must return the product, unused, for refund or credit.

## 100% SATISFACTION GUARANTEE

If you are not 100% satisfied with your Semroc product, we will make it right by providing whatever you consider fair, from refund to replacement.

Contact us at:

**Semroc Astronautics Corporation**  
Customer Service Department  
P.O. Box 1271  
Knightdale, North Carolina 27545

## JOIN THE NAR!

Sign up online at [www.nar.org](http://www.nar.org) to join the premier model rocketry organization. Semroc fully supports the National Association of Rocketry and recognizes it as the sport's official voice. The NAR is the oldest and largest sport rocketry organization in the world. Since 1957 over 80,000 serious sport rocket modelers have joined the NAR to take advantage of the fun and excitement of organized rocketry. It is always more fun if you fly with friends. The *Sport Rocketry* magazine is one of the best ways to keep informed of new developments in the hobby. Check online at [www.semroc.com/nar](http://www.semroc.com/nar) for promotions just for NAR members.



**52.** Mounting the engine: Whether the flight will have one engine or seven engines, all must be securely mounted. Masking tape will be required to keep the engines from kicking out at ejection time.

**53.** Refer to the model rocket engine manufacturer's instructions to complete the engine prepping. Different engines have different igniters and methods of hooking them up to the launch controllers. When firing more than one engine, always make sure you have at least a 12 volt car battery in top condition. The lead wire should be at least 16 gauge or less and no more than 20 feet in length. Make sure all connections are tight and the electrical system is in perfect order.

Hook up the igniters using bus bar as shown below or use "Clip Whips" designed for clusters.

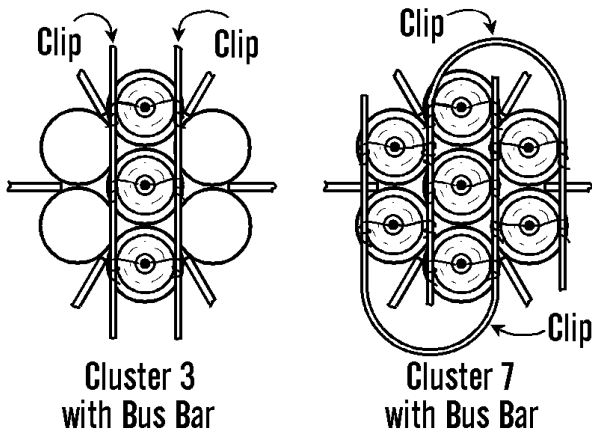

A full tutorial on clustering is outside the scope of these instructions. If you are not experienced with clustering, a search online will yield many tutorials to get you started on one of the most challenging propulsion methods for model rocketry.

**54.** Pack the recovery wadding from the top of the body tube. Use a sufficient quantity to protect the parachute, but not too much that it will interfere with the proper deployment of the parachutes.

**55.** Fold the parachutes and pack them and the shock cord on top of the recovery wadding. Slide the payload section into place, making sure it does not pinch the shock cord or parachute.

**56.** Carefully check all parts of your rocket before each flight as a part of your pre-flight checklist. Launch the Hydra VII from a 1/8" diameter by 36" long launch rod. A longer rod will result in better flight control and stability.

## About the Hydra VII™

The Semroc Hydra VII™ was designed in 1969 as the seventh Semroc-Kit. Designed to be a high performance large cluster payload rocket, the Hydra VII™ was the most complex kit Semroc introduced. Named after a multi-headed monster in Greek mythology, the Hydra was a monster of a rocket with seven C engines! Construction was much more challenging than most other model rockets of the time. Igniting all seven engines was a major accomplishment, but rewarding flights were still possible. In small fields, a single C engine provided a great low altitude demonstration flight. The Hydra VII™ was stock number KB-7 and retailed for \$5.98 when it was first introduced.

The Retro-Repro™ Hydra VII™ is updated by using laser-cut balsa fins and a Kevlar® shock cord attachment. The original paper augments shroud has been replaced by a much sturdier spiral tube. The original balsa nose cones and body tubes are still used. The original two 12" parachutes have been increased to three to give more options for different flight profiles.

### BEFORE YOU START!

Make sure you have all the parts included in this kit that are listed in the Parts List in the center of these instructions. In addition to the parts included in this kit, you will also need the tools and materials listed below. Read the entire instructions before beginning to assemble your rocket. When you are thoroughly familiar with these instructions, begin construction. Read each step and study the accompanying drawings. Check off each step as it is completed. In each step, test-fit the parts together before applying any glue. It is sometimes necessary to sand lightly or build-up some parts to obtain a precision fit. If you are uncertain of the location of some parts, refer to the exploded view in the center of these instructions. It is important that you always ensure that you have adequate glue joints.

**TOOLS:** In addition to the parts supplied, you will need the following tools to assemble and finish this kit.

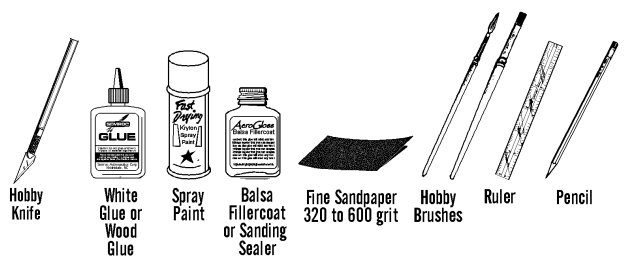

# ASSEMBLY

❑ **1.** These instructions are presented in a logical order to help you put your Hydra VII together quickly and efficiently. Check off each step as you complete it and we hope you enjoy putting this kit together and flying it.

## FIN PREPARATION

❑ **2.** Lightly sand each side of all four sheets of the laser-cut fins. Carefully push the laser-cut fins from their sheet. Start at one point on each fin and slowly and gently work around the fin.

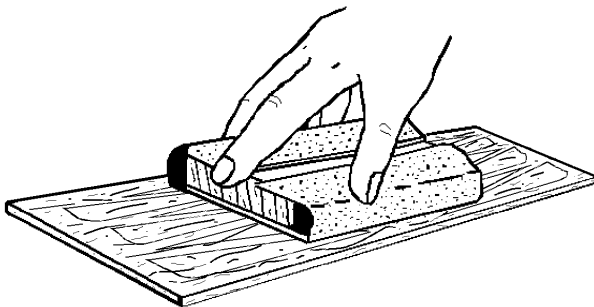

❑ **3.** Stack all the fins in groups of three fins each. Line each group up squarely and sand the fins back and forth over some fine sandpaper to get rid of the hold-in tabs as shown below.

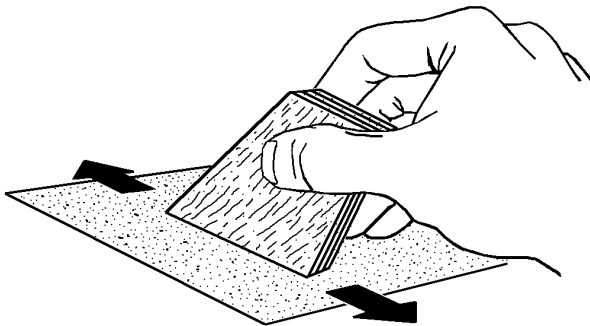

❑ **4.** Repeat for all three sets of fins. Round all leading edges. Round or taper all trailing edges. Leave the tip and root edges flat. Use the diagram to identify edges and fin types.

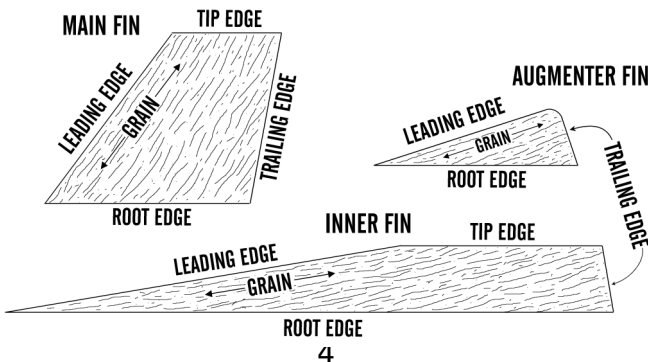

❑ **49.** Spray painting your model with a fast-drying enamel will produce the best results. PATIENCE...is the most important ingredient. Use several thin coats, allowing each coat to completely dry before the next coat. Start each spray a few inches above the model and end a few inches below the model. Keep the can about 12" away and use quick light coats. The final coat can be a little heavier to give the model a glossy wet-looking finish.

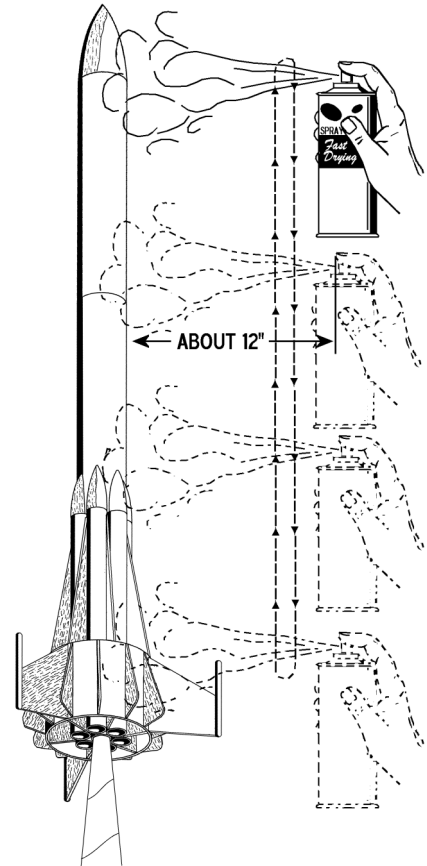

❑ **50.** After the paint has dried, decals should be applied. The decals supplied with the Hydra VII are waterslide decals. Each decal should be cut separately from the sheet. Completely apply one of the decals before starting the next. Think about where you want to apply each decal and check for fit before wetting the decal. There is no set place for each decal. Use your imagination.

## LAUNCH PREPARATION

❑ **51.** The recommended engine for your first flight is a single C6-3 in the central engine tube. Remember to always have an engine with a delay in the central engine tube. All the outer engines should be booster types with -0 delay.

- ❑ **44.** Check the nose block for fit. It may be necessary to sand it gently if the fit is too tight or build it up with masking tape if too loose. Mark the nose block 3/4" from one end. Apply glue to the inside the remaining body tube at a distance of 1/4" from one end.



- ❑ **45.** Slide the nose block, with screw eye pointing out, into the body tube until the mark is even with the end of the body tube. Do not stop until the nose block is in place or the glue may set prematurely.



- ❑ **46.** Insert the nose cone in the body tube and check for proper fit. The nose cone should be snug to hold itself in alignment. If it is too loose, add masking tape. If it is too tight, sand the shoulder slightly. Do not glue the nose cone so you can access the payload area.



- ❑ **47.** Finish the payload assembly by tying one end of the other elastic cord to the screw eye. Tie a 1" loop in the other end and attach the final chute through the loop as was done for the main chutes.

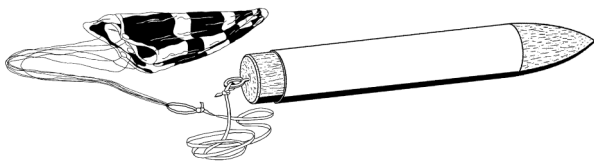

## FINISHING

- ❑ **48.** If you have not sealed the fins and nose cone, now is the time to complete this part of the assembly. After all balsa surfaces have been prepared, wipe off all balsa dust with a dry cloth. First spray the model with an enamel primer. Choose a high visibility color combination like white and red for the final color.

- ❑ **5.** Since the fins are so close together after they are glued to the body tubes, it is easier to fill the balsa fins now instead of after they are glued in place. For a smooth professional looking finish, fill the wood grain with balsa fillercoat or sanding sealer. When dry, sand with fine sandpaper. Repeat until smooth.

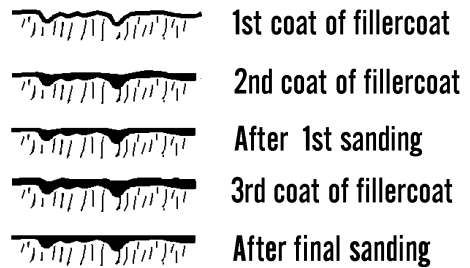
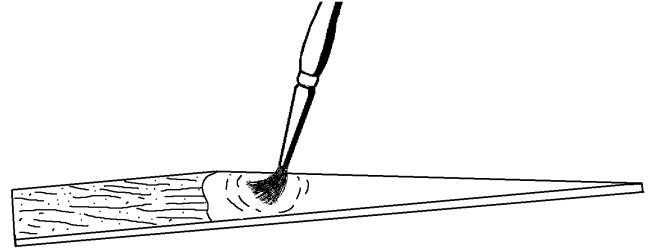

## ENGINE MOUNT

- ❑ **6.** Find a convenient channel or groove such as a partially open drawer, a door jamb (as shown), or a piece of molding. Using the channel, mark the full length of one of the small body tubes to provide a line for applying a bead of glue.

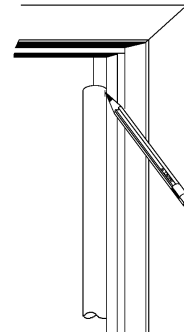

- ❑ **7.** Place the tube on a flat, smooth surface with the bead of glue as shown.



❑ **8.** Glue the second tube to the first by aligning it along the bead of glue. A single sheet of newspaper or wax paper under the tubes will keep glue off your work surface.

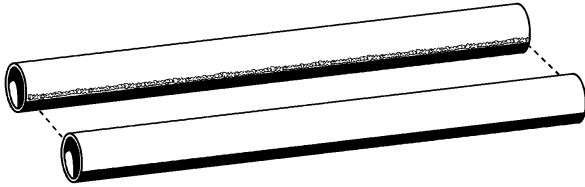

❑ **9.** Make sure both tubes touch and are laying flat on the work surface. Both ends should also be even. Getting these first two tubes aligned properly is very important. They form the foundation for the rest of the tubes. In each step, make sure the ends are even and the tubes are in good parallel alignment. Allow these first two tubes to dry.



❑ **10.** Test fit the third tube on the first two tubes. Using a pencil, mark the intersection of the third (top) tube with each of the two bottom tubes.

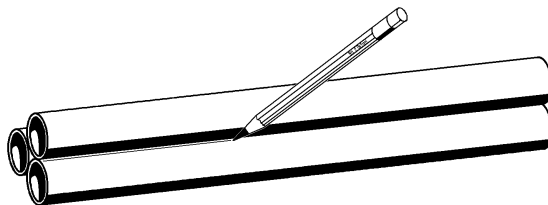

❑ **11.** Apply two beads of glue along each of the lines marked on the bottom tubes. Place the third tube on the first two. Rotate it slightly to smooth the glue and make a tight fit.



❑ **41.** Assemble all three chutes using instructions printed on canopy. Attach one chute by passing the lines through the loop in the elastic cord and then passing the chute through the shroud line loop as shown. If you are flying in low winds or with more than one engine. Attach a second chute through the same loop in the elastic cord.

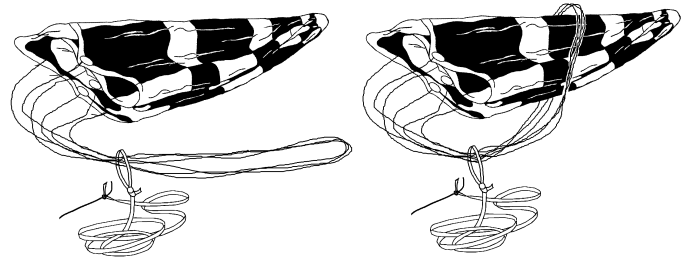

❑ **42.** Glue the launch lug at one of the inner fin-to-engine tube joints just above the augments shroud. This completes the assembly of the main section.

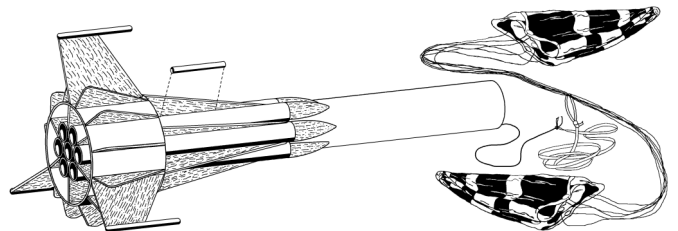

## PAYLOAD SECTION

❑ **43.** Turn the screw eye into the center of the base of the nose block. Unscrew it and squirt glue into the hole. Reinstall the screw eye and wipe off any excess glue.

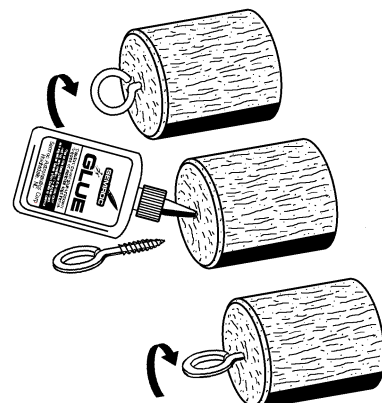

# MAIN FINAL ASSEMBLY

- ❑ **38.** Prepare the main shock cord as follows. Line up one end of the elastic shock cord with the free end of the Kevlar cord and tie an overhand knot at the end of the two cords. Pull the knot tight and place a small drop of white glue on the knot to prevent it from loosening.

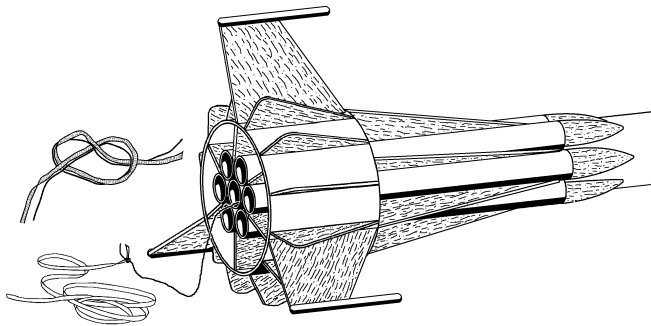

- ❑ **39.** Feed the shock cord and yellow Kevlar® cord back through the center engine mount tube until they come out the opposite end. Make sure they are pulled all the way through the engine mount. It may be necessary to shake the tube or pull the shock cord through with a coat hanger or long, thin wood dowel.

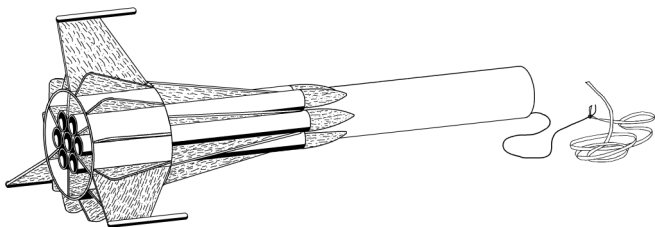

- ❑ **40.** Place a loop about 1" in diameter in the free end of the elastic cord. The main chute or chutes will be attached to this loop.

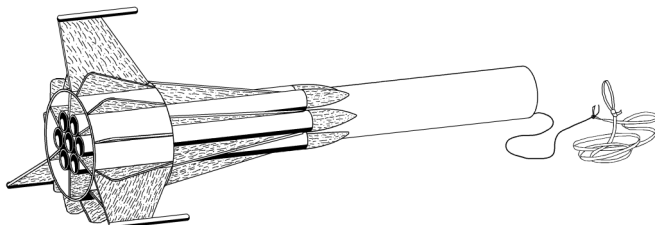

- ❑ **12.** You now have three of the seven tubes glued in place. Check from the end to make sure they are all in proper alignment. Allow to dry thoroughly.



- ❑ **13.** Test fit the fourth tube and mark the third and second tube as in step 10. Run two beads of glue along the pencil lines. Place the fourth tube on the beads of glue. Rotate it slightly to smooth the glue. Prop the assembly so the last tube does not roll off.

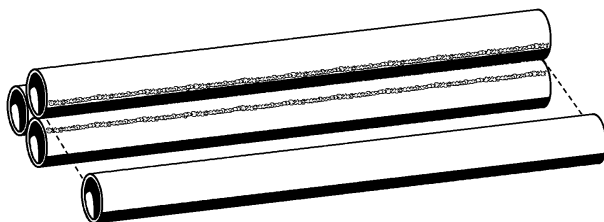

- ❑ **14.** Four of the seven tubes are now glued. When this assembly has dried completely, place a thin fillet of glue along each of the exposed joints and smooth with your finger.

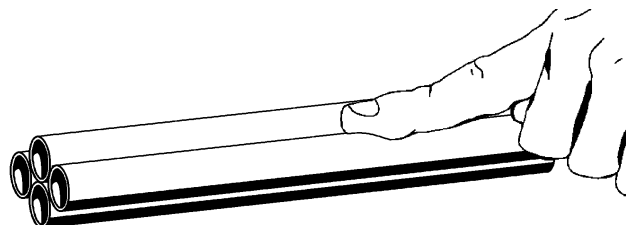

- ❑ **15.** Test fit the fifth tube and mark the third and fourth as in step 10. Run two beads of glue along the pencil lines. Place the fifth tube on the beads of glue. Rotate it slightly to smooth the glue.

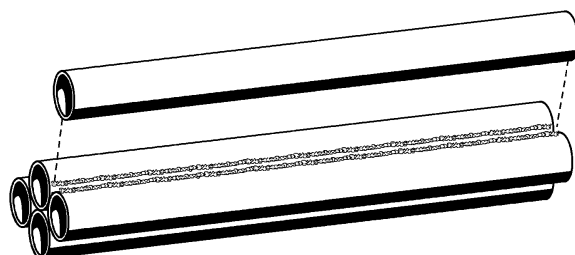

- ❑ **16.** Allow the glue to dry thoroughly. Rotate the assembly as shown for attaching the final two tubes.

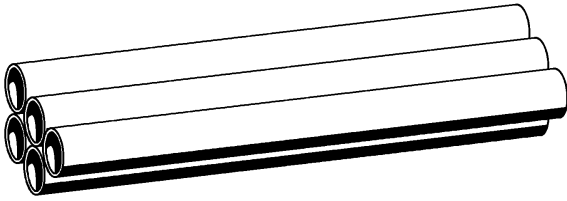

- ❑ **17.** Test fit the sixth tube and mark the underlying tubes. Run two beads of glue along the pencil lines. Place the sixth tube on the beads of glue. Rotate it slightly to smooth the glue.

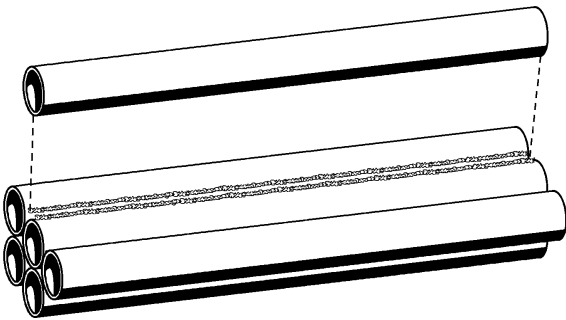

- ❑ **18.** Check the alignment from the end. Allow the glue to dry thoroughly. You now have only one more engine tube to attach.

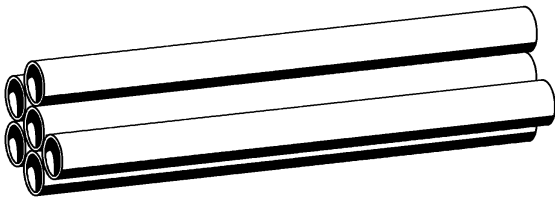

- ❑ **19.** Test fit the last tube and mark the tubes under it. Run a bead of glue along each pencil line. Since the last tube contacts three tubes, run an additional bead on the middle tube. See diagram for exact location. Place the seventh and last tube on the beads of glue. Rotate it slightly to smooth the glue.

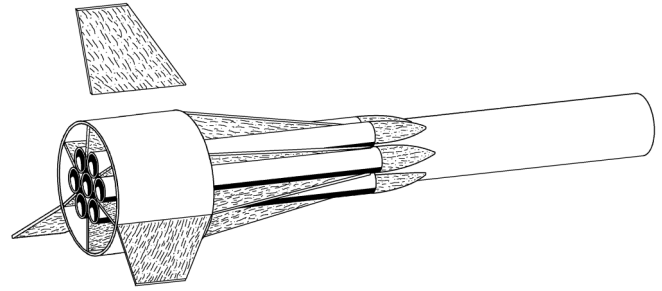
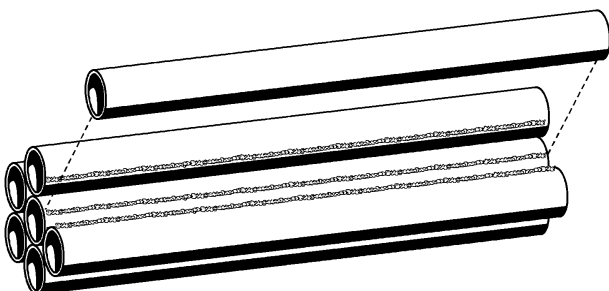

## AUGMENTER FINS

- ❑ **36.** Space all twelve augments fins on the lines previously marked on the shroud. There should be four augments fins between each pair of main fins. Allow them to dry and run a fillet of glue along each joint.

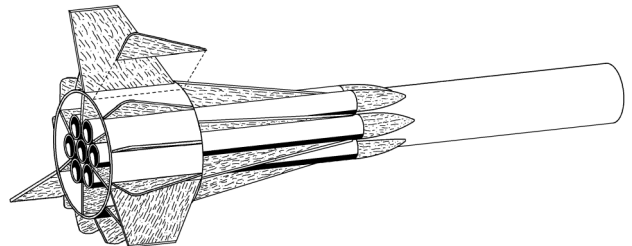

## FIN PODS

- ❑ **37.** Cut the 3/16" wood dowel into three pieces, each 3" in length. A razor saw works best, but a hobby knife rolled back and forth over the mark will work with patience. Round all the ends with sandpaper. Glue one dowel on the tip edge of each of the three main fins so the bottom of the dowel is even with the trailing edge of the fin. Make sure the dowel is in line with the fin. Allow to dry and run a fillet of glue along each joint to form a smooth transition.

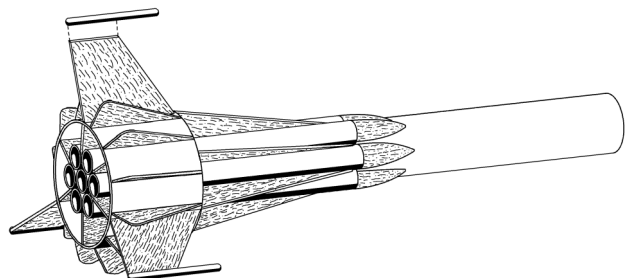



**33.** Place the sanded nose cones inside the top of the six outer body tubes in the engine assembly. They should form a circle on the inside. One of the large body tubes should fit down inside the ring formed by the nose cones. If the main body tube does not fit all the way down in the engine assembly, some of the nose cones will have to be sanded more. When the correct fit is achieved, all the nose cones should be glued in position. Before the glue sets, apply a layer of glue on the inside surfaces of all six nose cone halves where they will make contact with the main body tube.

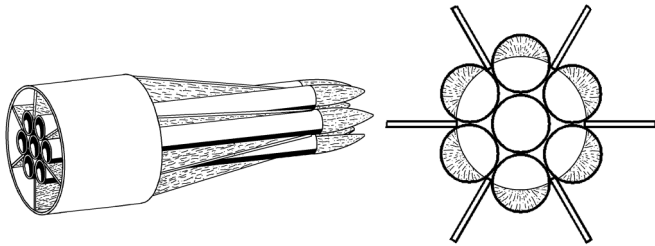

## MAIN BODY TUBE

**34.** Insert the main body tube, making sure it is all the way down inside the nose cones and resting on the outer engine tubes. Hold the nose cones tight against the main body tube until the glue has set. Allow to dry thoroughly. After the assembly is dry, run a fillet of glue along each nose cone-body tube joint for maximum strength and streamlining.

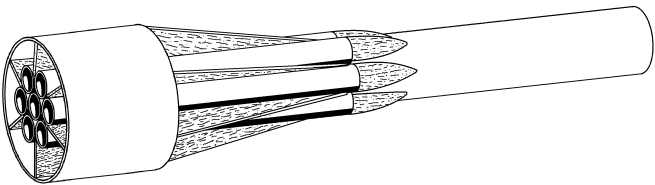

## MAIN FINS

**35.** Glue one of the main fins on the aug-  
menter shroud directly over one of the inner fins. Sight the fin from the top. It should look like an extension of the inner fin. Allow the glue to set. Skip one inner fin and glue the second fin directly over the next one. Repeat for the third main fin. There should be a main fin aligned with every other inner fin as shown. Allow all the joints to dry, then run a good fillet of glue along each fin joint.

**20.** All seven engine tubes are now glued. Allow all glue to dry. Apply small fillets of glue to all the exposed joints that have not been done yet.

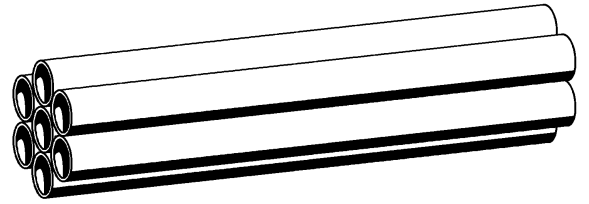

## INNER FINS

**21.** Glue the first inner fin in between two of the engine tubes as shown below. Make sure the trailing edge is even with the bottom of the engine tubes.

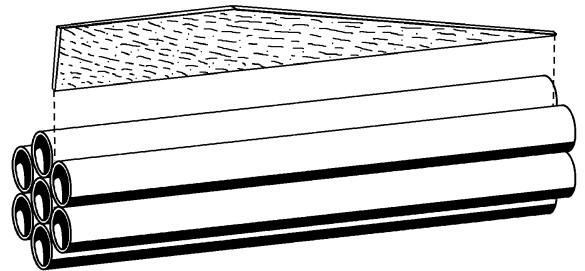

**22.** Glue the remaining five inner fins using the end view below as a guide for proper alignment.

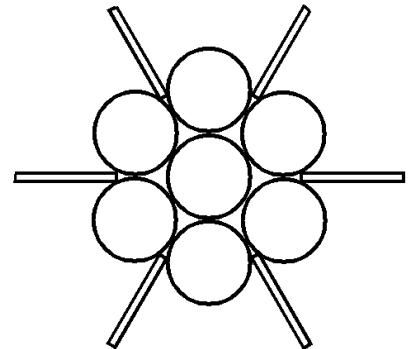

**23.** When all six inner fins are attached, wait for all glue to dry. Stand the assembly on end and watch closely for runs.

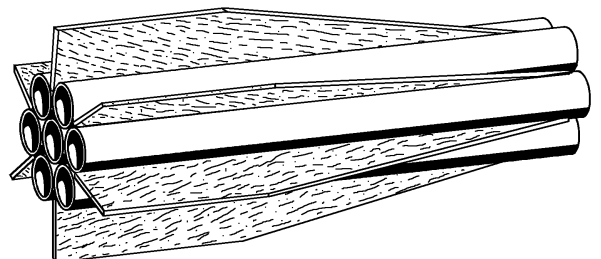

# AUGMENTER SHROUD

❑ **24.** Using the fin alignment guide, mark the largest body tube. Each of the twelve marks on the outside of the tube will align the augmentor fins. Mark the six inner points that will align the inner fins. Using a convenient channel, mark a line the full length of tube for each fin.



❑ **25.** Check the augmentor shroud for fit. It might be necessary to sand a small amount off the tip edge of the inner fins to get a snug fit. Align the marks on the inside of the tube with the inner fins. Line up the shroud with each end of the inner fins. Run a fillet of glue along each joint of the inner fins to the shroud. Stand on end and allow to dry.

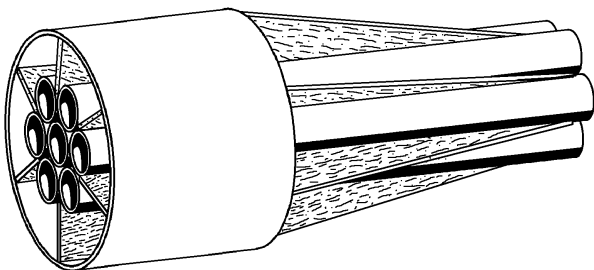

❑ **31.** Now mount the final thrust ring in the center. Apply a bead of glue inside the center engine tube at a depth of about 2 1/4". Insert the free end of the Kevlar® Thread through the engine spacing tube and pull back to keep it clear of the spacing tube. Push the ring and thread forward until the mark on the engine spacing tube is even with the end of the engine tube. Remove the engine spacing tube immediately allowing the thread to pass back through the tube. Leave the thread hanging from the end of the tube for now.

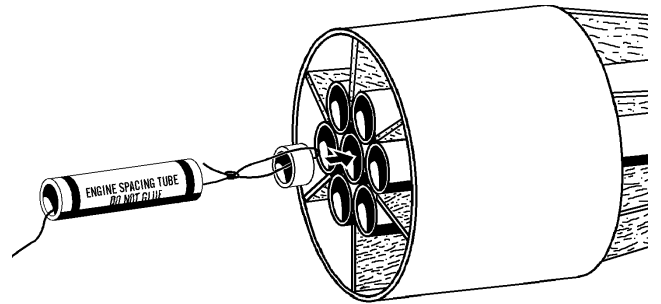

# INTERSTAGE SHROUDS

❑ **32.** The three small nose cones will be split in half to make the six interstage shrouds. Carefully cut one nose cone in half, forming two identical pieces. The best method involves the use of a small micro-saw, but a hobby knife or single edge razor blade will work as well. Follow the same procedure until you have six identical nose cone halves. Using medium sandpaper, wrap a piece around one of the large (ST-1690) body tubes with the sanding surface outward. Sand the nose cones up and down the length of the tube until they have the shape indicated below. Sand with care to obtain the exact shape. Do not take off too much balsa.

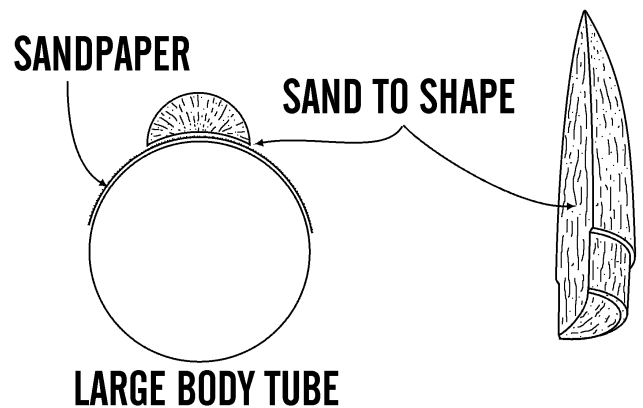

LARGE BODY TUBE

- ❑ **28.** Tie one end of the yellow Kevlar® cord to the remaining thrust ring by forming a loop around the ring and tying an overhand knot in the two ends. Pull the knot tight and place a drop of white glue on the knot.

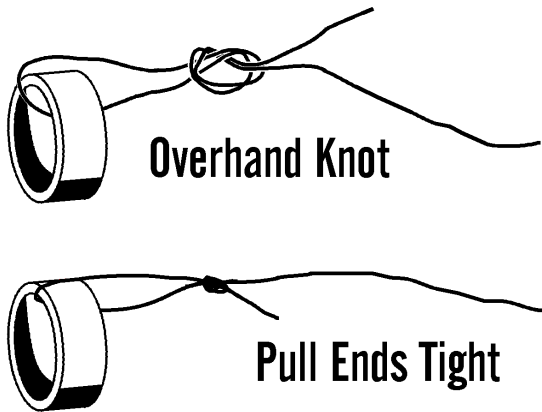

- ❑ **29.** Using the supplied glue applicator, apply a bead of glue inside one of the outside engine tubes at a depth of about 2 1/4". Try to avoid getting any glue less than 2 1/4" or the engine may be difficult to insert and remove.

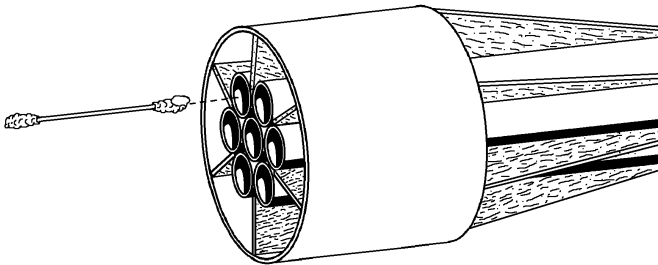

- ❑ **30.** Apply the first engine plug next. Insert one plug assembly in the engine tube that you just applied glue and push it forward until the mark on the engine spacing tube is even with the end of the engine tube. Don't push the plug in too far. Remove the engine spacing tube immediately or it will possibly set in place. Repeat with all the other five outer engine tubes. Leave the center tube for later.

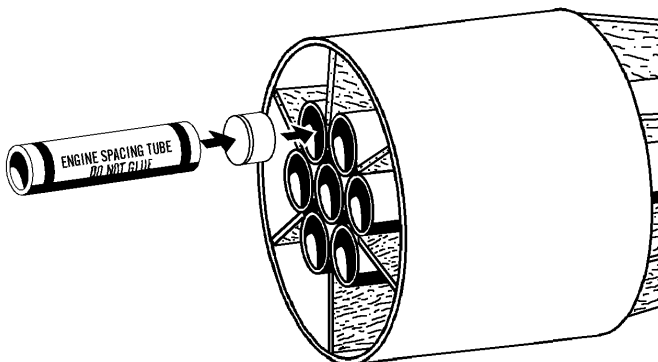

# THRUST RINGS

- ❑ **26.** Mark the empty engine casing 3/8" from one end to use for spacing the thrust rings in the engine tubes.

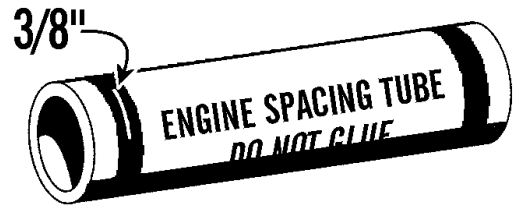

- ❑ **27.** Plug six of the thrust rings using the discs on the laser-cut fiberboard sheet. Begin with the first ring by checking the ring and plug for fit. Apply a bead of glue around the top edge of one of the thrust rings. Center the plug on the ring. Wipe any excess glue on the outside of the assembly. When dry, turn the ring upside down and apply a generous fillet around the inside joint. Repeat for the other five assemblies.

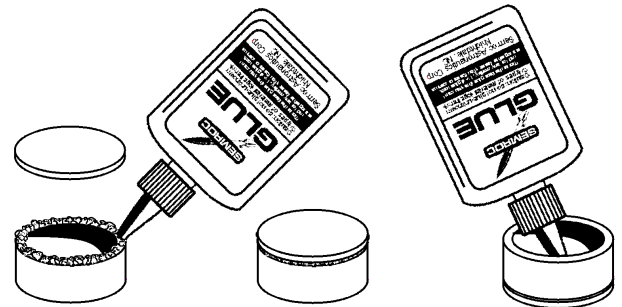

**NOTE:** Some builders prefer to leave more engine mounts open to increase the odds that in case all engines do not ignite, there is a backup.

If you do decide to leave more engine channels open, make sure engines with delays are used in all the open channels. Make sure all the engines are the same type with the same delay.

Add some recovery wadding inside the top of each engine that is exposed so it will not "top fire". Make sure each tube is plugged either with an engine or a block. If there is an opening, the recovery system will probably fail.

## Parts List

A	2	Body Tubes	.....	ST-1690
B	7	Body Tubes	.....	ST-790
C	1	Body Tube	.....	ST-3630
D	1	Balsa Nose Cone	.....	BC-1631
E	3	Balsa Nose Cones	.....	BC-714
F	1	Laser Cut Fin Set	.....	FV-29
G	1	Balsa Tube Coupler	.....	BTC-16
H	1	Launch Lug	.....	LL-122
I	1	Screw Eye	.....	SE-10
J	2	Elastic Cord	.....	EC-124
K	1	Kevlar Thread	.....	SCK-24
L	3	Plastic Parachutes	.....	RC-12
M	3	Tape Discs	.....	TD-6
N	3	Shroud Lines	.....	SLT-6
O	1	Wood Dowel	.....	WD-39
P	7	Thrust Rings	.....	TR-7
Q	1	Plug Set	.....	IKV-29P
R	1	Decal	.....	DKV-29
S	1	Empty Casing	.....	MC-727
T	1	Glue Applicator	.....	GA-1

## EXPLODED VIEW

