



Model Rocket Safety Code

- 1. Materials.** I will use only lightweight, non-metal parts for the nose, body, and fins of my rocket.
- 2. Motors.** I will use only certified, commercially-made model rocket motors, and will not tamper with these motors or use them for any purposes except those recommended by the manufacturer.
- 3. Ignition System.** I will launch my rockets with an electrical launch system and electrical motor igniters. My launch system will have a safety interlock in series with the launch switch, and will use a launch switch that returns to the "off" position when released.
- 4. Misfires.** If my rocket does not launch when I press the button of my electrical launch system, I will remove the launcher's safety interlock or disconnect its battery, and will wait 60 seconds after the last launch attempt before allowing anyone to approach the rocket.
- 5. Launch Safety.** I will use a countdown before launch, and will ensure that everyone is paying attention and is a safe distance of at least 15 feet away when I launch rockets with D motors or smaller, and 30 feet when I launch larger rockets. If I am uncertain about the safety or stability of an untested rocket, I will check the stability before flight and will fly it only after warning spectators and clearing them away to a safe distance.
- 6. Launcher.** I will launch my rocket from a launch rod, tower, or rail that is pointed to within 30 degrees of the vertical to ensure that the rocket flies nearly straight up, and I will use a blast deflector to prevent the motor's exhaust from hitting the ground. To prevent accidental eye injury, I will place launchers so that the end of the launch rod is above eye level or will cap the end of the rod when it is not in use.
- 7. Size.** My model rocket will not weigh more than 1,500 grams (53 ounces) at liftoff and will not contain more than 125 grams (4.4 ounces) of propellant or 320 N-sec (71.9 pound-seconds) of total impulse. If my model rocket weighs more than one pound (453 grams) at liftoff or has more than four ounces (113 grams) of propellant, I will check and comply with Federal Aviation Administration regulations before flying.
- 8. Flight Safety.** I will not launch my rocket at targets, into clouds, or near airplanes, and will not put any flammable or explosive payload in my rocket.
- 9. Launch Site.** I will launch my rocket outdoors, in an open area at least as large as shown in the accompanying table, and in safe weather conditions with wind speeds no greater than 20 miles per hour. I will ensure that there is no dry grass close to the launch pad, and that the launch site does not present risk of grass fires.
- 10. Recovery System.** I will use a recovery system such as a streamer or parachute in my rocket so that it returns safely and undamaged and can be flown again, and I will use only flame-resistant or fireproof recovery system wadding in my rocket.
- 11. Recovery Safety.** I will not attempt to recover my rocket from power lines, tall trees, or other dangerous places.

LAUNCH SITE DIMENSIONS

Installed Total Impulse (N-sec)	Equivalent Motor Type	Minimum Site Dimensions (ft.)
0.00 — 1.25	1/4A	50
1.26 — 2.50	A	100
2.51 — 5.00	B	200
5.01 — 10.00	C	400
10.01 — 20.00	D	500
20.01 — 40.00	E	1000
40.01 — 80.00	F	1000
80.01 — 160.00	G	1000
160.01 — 320.00	2 Gs	1500

Orbital Transport™

NASA INSPIRED

EASY AND FUN TO BUILD

EXCITING FLIGHTS

BALSA NOSE CONES

FLYING MODEL ROCKET KIT

1968 AstroRepro

Designed by: Wayne Kellner

LASER CUT FINS

MADE IN THE USA

SEMROC

Made in the U.S.A by Semroc Astronautics Corporation - Knightdale, N.C. 27545

Orbital Transport™ Kit No. KV-66

Specifications	Booster	Glider	Engines
Body Diameter	0.976" (2.5 cm)	0.736" (1.9 cm)	B6-4
Length	23.0" (58.4 cm)	8.6" (21.8 cm)	C6-5
Fin Span	8.1" (20.6 cm)	5.4" (13.7 cm)	
Net Weight	1.8 oz. (51.1 g)	0.5 oz. (14.2 g)	

Glide/Parachute Recovery

What is a Retro-Repro?

A Retro-Repro™ is a reproduction of an out-of-production model rocket kit. It is a close approximation of a full scale model of an early historically significant model rocket kit from one of the many companies that pioneered the hobby over the past half century. A Retro-Repro™ is not a true clone or identical copy of the original. It incorporates improvements using modern technology, while keeping the flavor and build appeal of the early kits.

About Estes Industries, Inc.

In July 1958, G. Harry Stine of Model Missiles, Inc. in Denver, Colorado approached Vern Estes about making model rocket engines for them. On January 15, 1959, Vern's automated model rocket engine fabricating machine, "Mabel", produced the first of many millions of Estes model rocket engines. In 1960, Estes was producing more engines than Model Missiles could sell. Vern and his wife Gleda opened a mail order rocket company and introduced the Astron Scout and Astron Mark.

In 1961, a catalog was mimeographed and hand stitched on Gleda's sewing machine. Later that year, Estes Industries had outgrown the confined space in Denver. In December 1961, the entire operation was moved to an old farm in Penrose, Colorado quickly establishing the small town as the "Model Rocket Capital of the World."

Estes Industries was sold to Damon in September 1969. The name Estes is synonymous with model rocketry. Almost everyone remembers growing up firing Estes rockets or knowing someone that did. Estes Industries has introduced millions of youngsters of all ages to model rocketry for almost half a century.

September 28, 2008

Copyright © 2008 Semroc Astronautics Corporation
Box 1271 Knightdale, NC 27545 (919) 266-1977

LIMITATION OF LIABILITY

Model rockets are not toys, but are functional rockets made of lightweight materials and are launched with NAR or Tripoli safety certified model rocket motors, electrically ignited and flown in accordance with the NAR Model Rocket Safety Code. If misused, model rockets can cause serious injury and property damage. Semroc certifies that it has exercised reasonable diligence in the design and manufacture of its products. Semroc cannot assume any liability for the storage, transportation, or usage of its products. Semroc shall not be held responsible for any personal injury or property damage whatsoever arising out of the handling, storage, use, or misuse of our products. The buyer assumes all risks and liabilities therefrom and accepts and uses Semroc products on these conditions.

Your purchase and use of any Semroc products is construed as your agreement to and acceptance of these terms. If you do not agree to these terms and conditions, you must return the product, unused, for refund or credit.

100% SATISFACTION GUARANTEE

If you are not 100% satisfied with your Semroc product, we will make it right by providing whatever you consider fair, from refund to replacement.

Contact us at:

Semroc Astronautics Corporation
Customer Service Department
P.O. Box 1271
Knightdale, North Carolina 27545

JOIN THE NAR!

Sign up online at www.nar.org to join the premier model rocketry organization. Semroc fully supports the National Association of Rocketry and recognizes it as the sport's official voice. The NAR is the oldest and largest sport rocketry organization in the world. Since 1957 over 80,000 serious sport rocket modelers have joined the NAR to take advantage of the fun and excitement of organized rocketry. It is always more fun if you fly with friends. The *Sport Rocketry* magazine is one of the best ways to keep informed of new developments in the hobby. Check online at www.semroc.com/nar for promotions just for NAR members.



FLIGHT PREPPING

❑ **53.** The B4-4 and C6-5 are the two recommended engines for the Orbital Transport™. Insert it into the booster and make sure the engine hook will retain it.

❑ **54.** Pack the recovery wadding from the top of the body tube. Use a sufficient quantity to protect the parachute, but not too much that there is no room left.

❑ **55.** Fold the parachute and pack it and the shock cord on top of the recovery wadding. Slide the nose cone into place, making sure it does not pinch the shock cord or parachute.

❑ **56.** Attach the glider to the booster by hooking the hold-down support on the bottom of the glider into the launch lug on the top of the booster. The glider should rest on the glider supports when held in a vertical position.

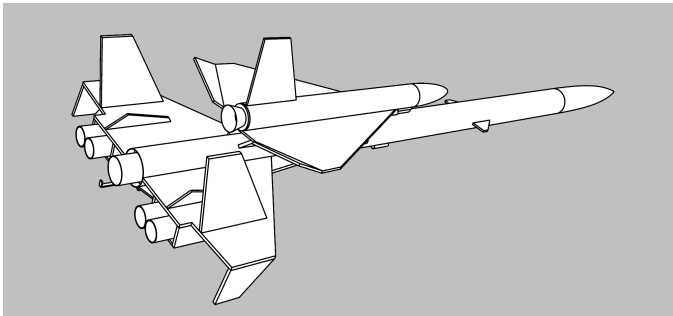

❑ **57.** Refer to the model rocket engine manufacturer's instructions to complete the engine prepping. Different engines have different igniters and methods of hooking them up to the launch controllers.

❑ **58.** Carefully check all parts of your rocket before each flight as a part of your pre-flight checklist. Launch the Orbital Transport™ from a 1/8" diameter by 36" long launch rod. Always launch in a vertical position in calm winds. Use the smaller engine for the first flights.

About the Orbital Transport™

The Estes Orbital Transport was introduced in Catalog #683 in late 1968. It was designed by Wayne Kellner, one of the most prolific and innovative designers at Estes Industries. The Orbital Transport was based on an early NASA scramjet design for the Space Shuttle. It featured a parasite glider that deployed at ejection and parachute recovery for the booster. The Orbital Transport was released as Cat. No. K-42 and had an introductory price of \$2.50.

The Semroc Retro-Repro™ Orbital Transport™ is very close to the original with some modern changes. The original balsa nose cones are kept. All fins are precision laser-cut balsa. A Kevlar shock cord mount is added for better retention. The original rubber shock cord is replaced with elastic. The 18" parachute is reduced to 12" for less drift.

BEFORE YOU START!

Make sure you have all the parts included in this kit that are listed in the Parts List in the center of these instructions. In addition to the parts included in this kit, you will also need the tools and materials listed below. Read the entire instructions before beginning to assemble your rocket. When you are thoroughly familiar with these instructions, begin construction. Read each step and study the accompanying drawings. Check off each step as it is completed. In each step, test-fit the parts together before applying any glue. It is sometimes necessary to sand lightly or build-up some parts to obtain a precision fit. If you are uncertain of the location of some parts, refer to the exploded view in the center of these instructions. It is important that you always ensure that you have adequate glue joints.

TOOLS: In addition to the parts supplied, you will need the following tools to assemble and finish this kit. Masking tape and wax paper are also required.

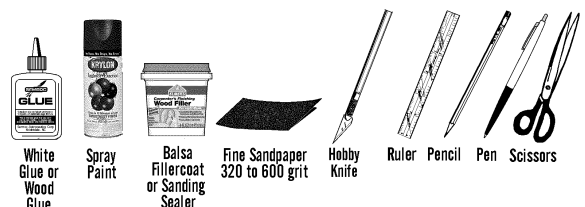

ASSEMBLY

❑ **1.** These instructions are presented in a logical order to help you put your Orbital Transport™ together quickly and efficiently. Check off each step as you complete it and we hope you enjoy putting this kit together.

PARTS IDENTIFICATION

❑ **2.** There are many different balsa parts included in this kit. Use the guide below to identify the parts that are called out in these instructions. Some of the parts are similar, but will not work if exchanged. Sheet A and Sheet B are similar, except the main wing parts (1) and (2) are mirror images for left and right. The balsa parts will be referred as (#) in these instructions.

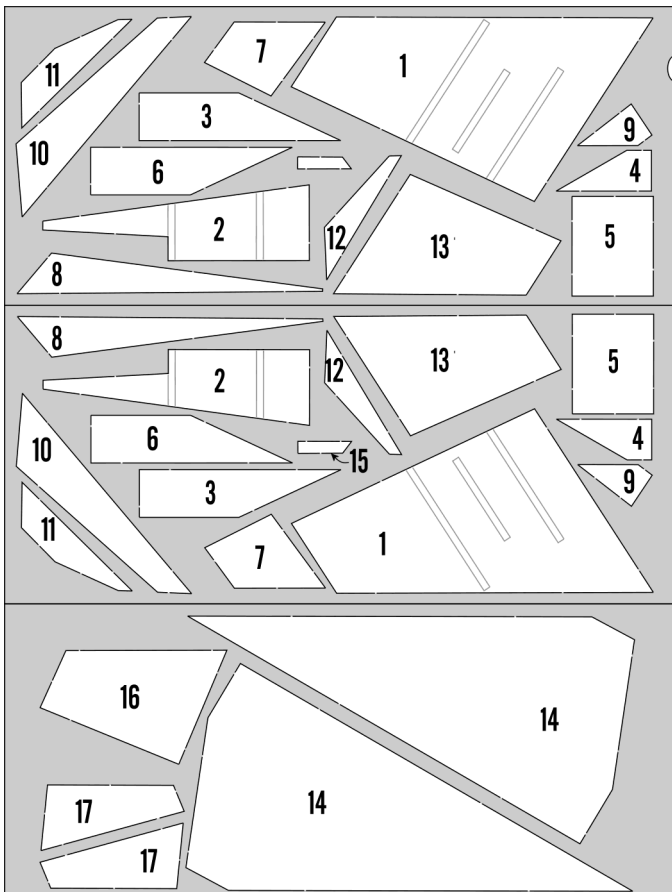

BALSA PREPARATIONS

❑ **3.** Lightly sand each side of the laser-cut balsa fin sheet. Carefully push the laser-cut fins from the sheet. Start at one point on each fin and slowly and gently work around the fin.

❑ **51.** After the paint has dried, decals should be applied. The decals supplied with the Orbital Transport™ are waterslide decals. Refer to the photo on the front and the diagram below for decal placement. Check for fit before wetting the decal. A drop of detergent in the water will allow for more movement before the decal sets.

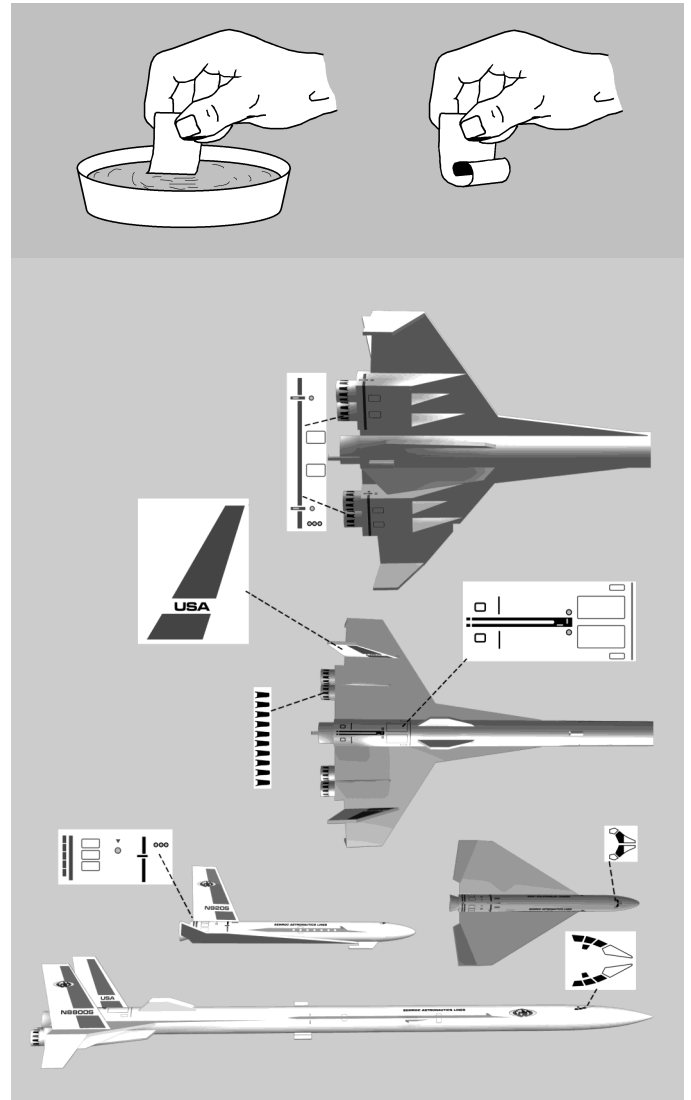

GLIDE TRIMMING

❑ **52.** Locate a clear grassy area free of objects that will damage your glider. Face the wind and gently toss the glider with a slight angle of attack upward. The elevons may be adjusted with a little heat applied to the glue joint using a light bulb or hair dryer on low heat. If the glider stalls, lower both flaps and try again. If it dives, raise the elevons slightly and retry. If it dives, lower them slightly. If it turns in flight, lower the elevon on the side that turns until it glides straight. If you have a very small field, you may want the glider to turn to stay in the area.

FINISHING

48. When the fillets have dried, prepare balsa for a smooth professional looking finish. Fill the wood grain with Fill'n'Finish, balsa fillercoat, or sanding sealer. When dry, sand with fine sandpaper. Repeat until smooth. Don't overdo it! Layers of unsanded filler can add much weight!



1st coat of fillercoat



2nd coat of fillercoat



After 1st sanding



3rd coat of fillercoat



After 1st sanding

49. After all balsa surfaces have been prepared, wipe off all wood dust with a dry cloth. First spray the model with an enamel primer, then spray both the booster and glider gloss white.

50. Spray painting your model with a fast-drying enamel will produce the best results. PATIENCE...is the most important ingredient. Use several thin coats, allowing each coat to completely dry before the next coat. Start each spray a few inches above the model and end a few inches below the model. Keep the can about 12" away and use quick light coats. The final coat can be a little heavier to give the model a glossy wet-looking finish.

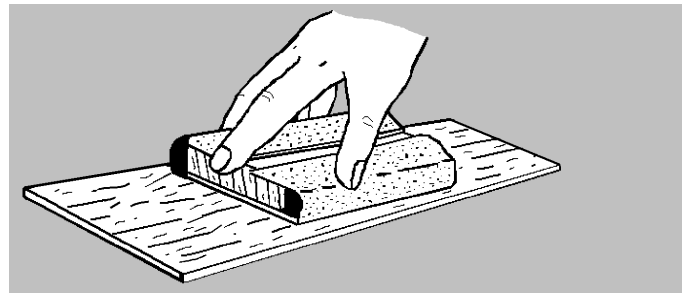
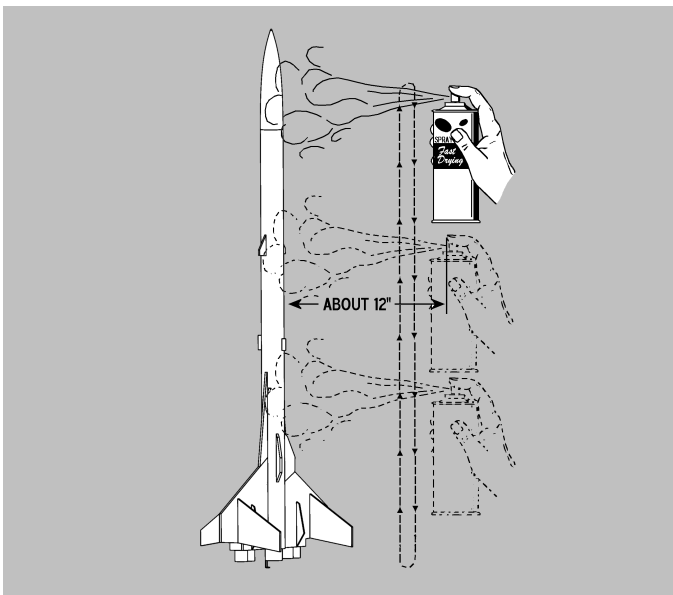

4. Stack all the like fins in groups. Line each group up squarely and sand the fins back and forth over some fine sandpaper to get rid of the hold-in tabs as shown below.

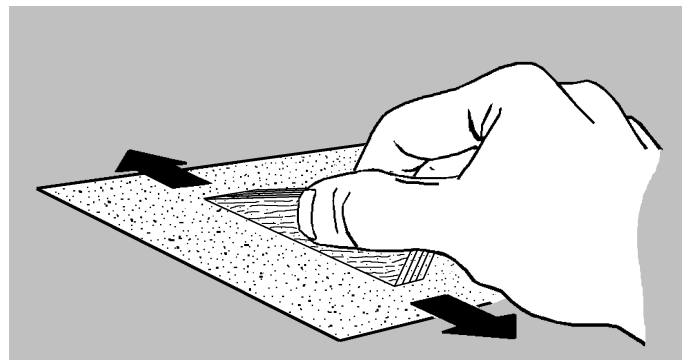

BOOSTER ASSEMBLY

5. Glue the main wing sections (1) and (2) together from one sheet with the etched lines to the top. Align section 2 so it achieves a square fit with section 1. Use wax paper over a flat surface to keep it from sticking. Repeat for the other wing and allow the main wing assemblies to dry completely.

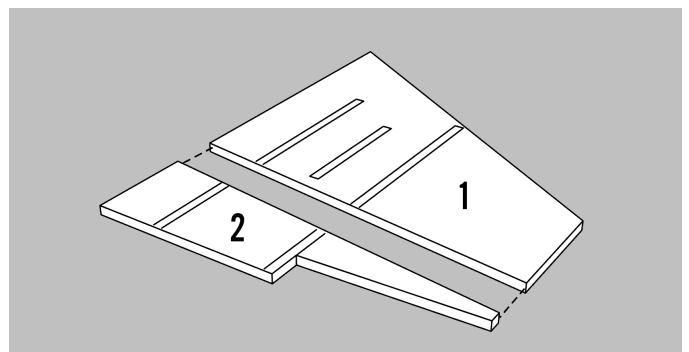

6. Apply a bead of glue along one side of one of the BT-5T body tubes. Attach a second BT-5T to the glue line. Align the ends and allow to dry on a flat surface. Repeat with the other pair of BT-5T body tubes and allow both assemblies to dry.

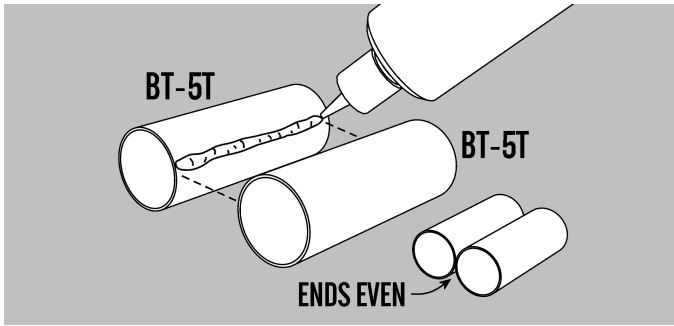

- ❑ **7.** Locate the scramjet outboard housing (3) and sand the leading edge to a round shape. Note that Part (3) and part (6) are identical. Apply a bead of glue along the outermost line on one of the wing assemblies. Align the housing so it is even with the trailing edge of the main wing and perpendicular to the surface.

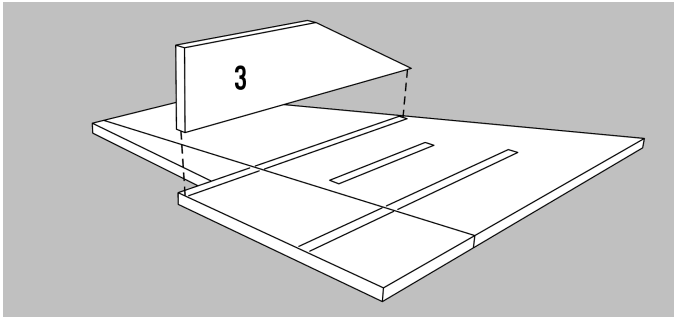

- ❑ **8.** Mark one pair of the scramjet tube assemblies 1/2" from one end. Glue the long (forward) ends of the tubes to the main wing with 1/2" overhanging and one side against the outboard housing. Check that the mark is even with the trailing edge of the wing and allow to dry.

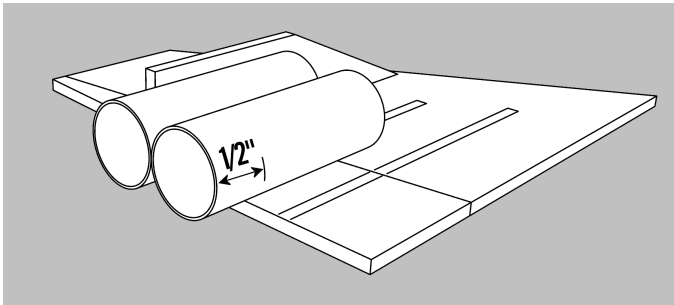

- ❑ **9.** Sand the leading edge of the intake vane (4) round and glue it in front of the scramjet tubes and on the lines provided on the main wing and allow to dry.

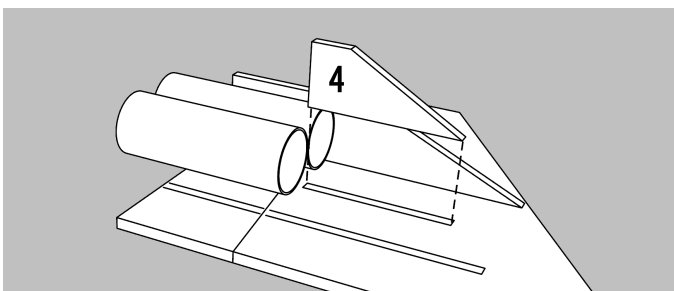

6

- ❑ **45.** Apply a thin bead of glue around the small end of the shroud and attach it to the center of the paper nose block on the end of the glider. When it is dry, run a heavier bead around the inside of the ring at the joint. Using a small amount of thin CA to stiffen the shroud will increase its durability.

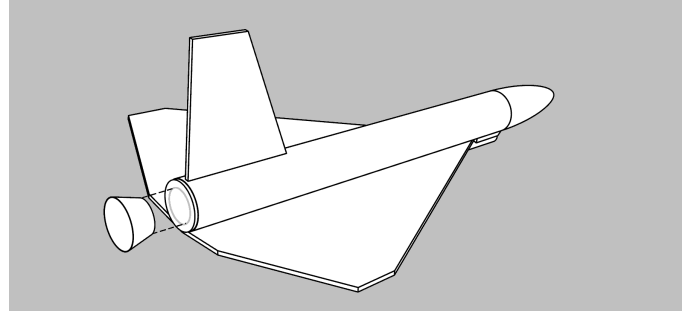

- ❑ **46.** Attach the elevons (17) to the trailing edges of the glider wings. Use the Elevon Guide to get the correct angle as shown.

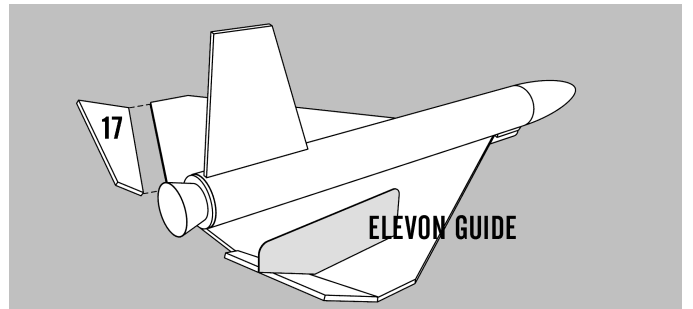

- ❑ **47.** Apply a bead of glue along the lower wing joint. Do not use any more glue than necessary.

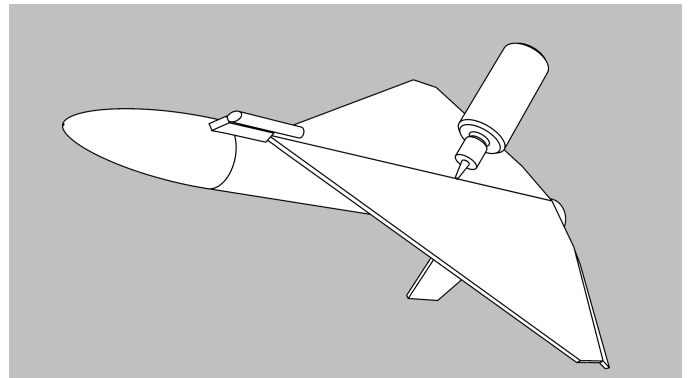

- ❑ **41.** Attach the hold-down assembly to the bottom of the glider even with the leading edge of the wing and perpendicular to the body tube. It will project slightly over the nose cone.

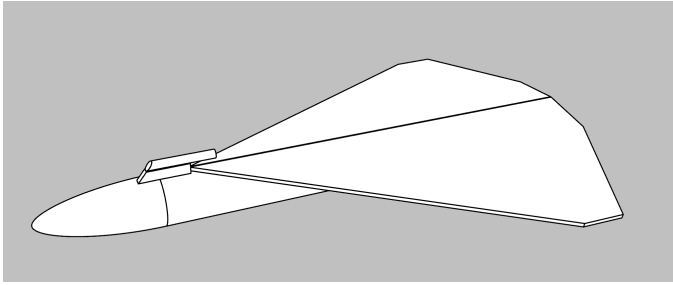

- ❑ **42.** Cut out the nozzle shroud from the pattern sheet. Form it into a cone and apply a small amount of glue to the tab on one end as denoted by the dotted line. Attach the free end over the glue so its end is even with the dotted line and hold in place until the glue sets.

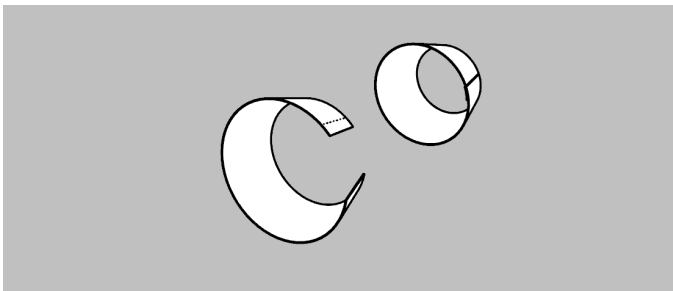

- ❑ **43.** Apply a small bead of glue around the outside edge of the paper nose block (NB-20P) and attach it to the end of the glider body tube. Align it carefully and wipe away any excess glue.

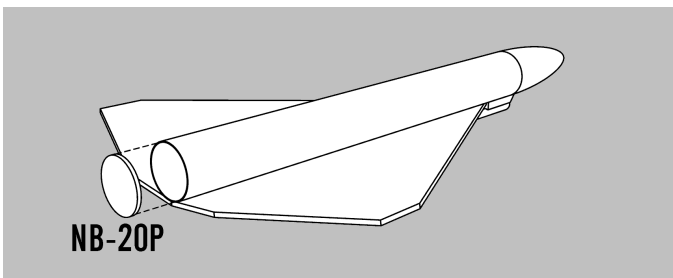

- ❑ **44.** Attach the glider rudder(16) on Line N on the top of the glider body tube. Make sure it is perpendicular to the body tube and allow to dry.

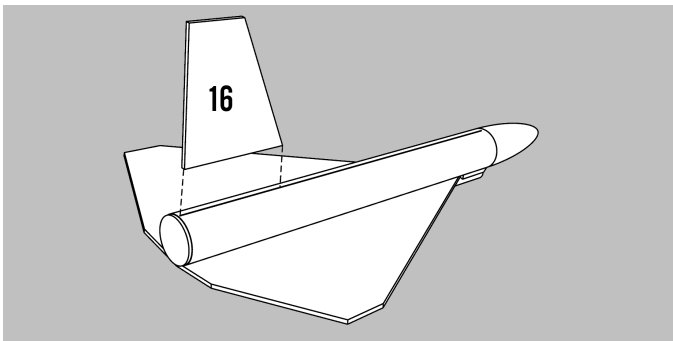

- ❑ **10.** Test the scramjet lower housing (5) for fit against the scramjet engines and the housing parts. Apply glue to the tops of the scramjet engines and the outboard housing and the intake vane and fit the lower housing in place. The back edge should be even with the trailing edge of the main fin.

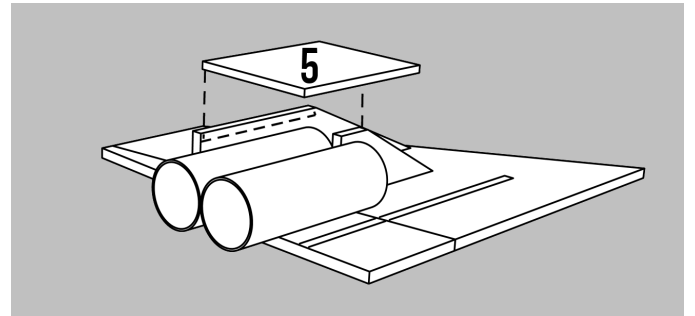

- ❑ **11.** Sand the leading edge of the inboard housing (6) round. Apply a bead of glue along the etched line on the main wing and along the edge of the lower housing and the edge of the scramjet engine and fit the inboard housing into place. All these parts should make a rectangular box around the two scramjet engines. Allow to dry.

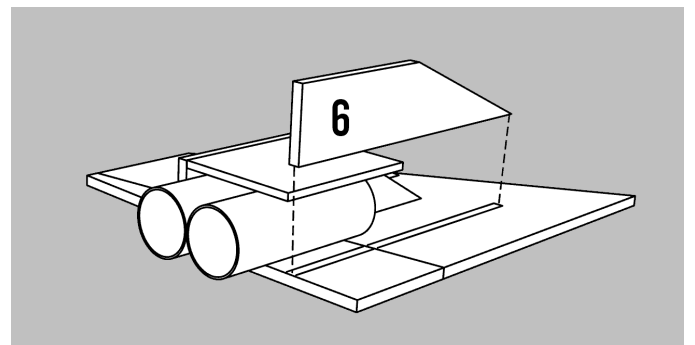

- ❑ **12.** Round the leading and trailing edges of the wingtip (7). Glue the wingtip even with the tip edge of the main wing on the same side as the scramjet engine housing. Make sure it is perpendicular and even with the edge. Allow the assembly to completely dry. Repeat this assembly with the second set of parts for the other main wing assembly and allow it to dry while assembling the engine mount.

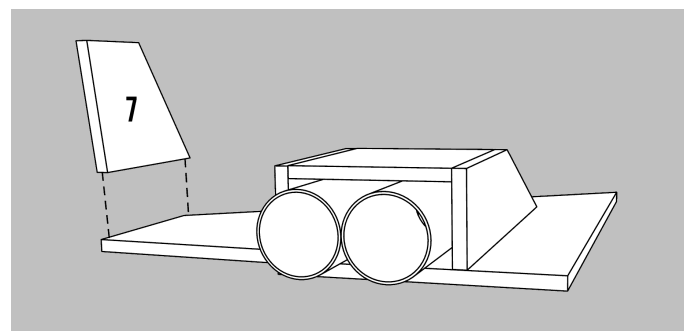

ENGINE MOUNT ASSEMBLY

- ❑ **13.** Using a hobby knife, punch a small 1/8" wide slit on the engine tube (BT-20J) 1/4" from one end. The BT-20J is 2-3/4" long. Insert one end of the engine hook (EH-28) in the slit.

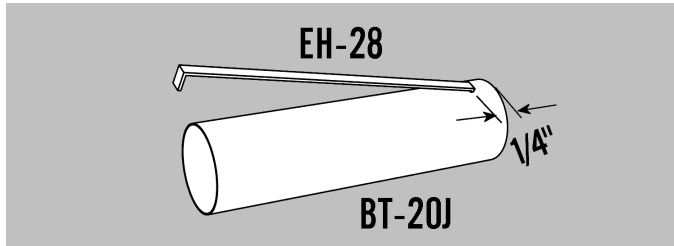

- ❑ **14.** Slide the Retaining Ring (HR-20) over the front of the engine tube and position it about 3/4" from the punched end of the engine tube.

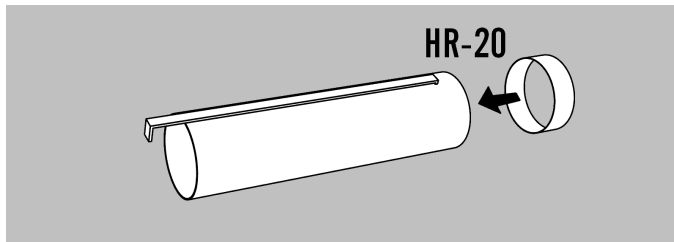

- ❑ **15.** Cut a notch 1/32" deep and 3/32" wide on the inside of one of the centering rings (AR-2050). This will allow the ring to clear the engine hook.

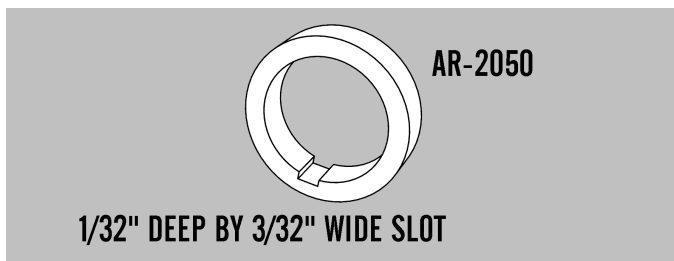

- ❑ **16.** Tie a knot in one end of the Kevlar® thread and pass it through the uncut centering ring. Slide the ring onto the top of the engine tube until it is even with the end of the tube. Slide the slotted centering ring with the slot over the engine hook until it is 3/4" from the bottom of the engine tube.

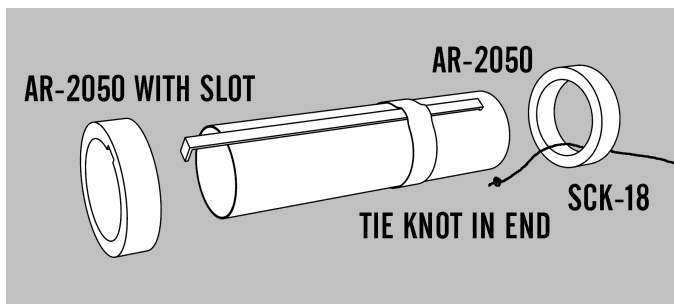

- ❑ **37.** Cut out the Glider Marking Guide from the pattern sheet. Wrap it around the glider body tube about 1/4" from one end. Hold it in place with a small piece of tape. Place a mark at both arrows and write the corresponding letter near each mark. Extend a line from each mark as you did with the main body tube.

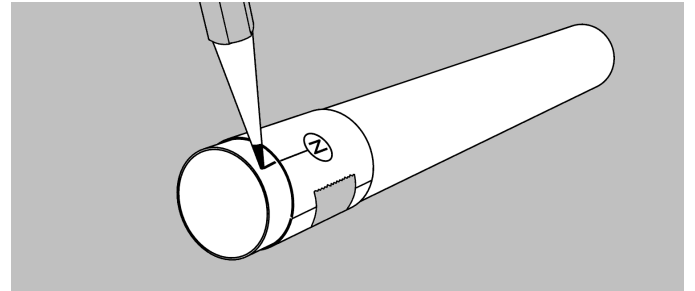

- ❑ **38.** Check the glider nose cone (BNC-20B) for fit, sanding if necessary. Apply a bead of glue inside one end of the glider body tube and insert the nose cone.

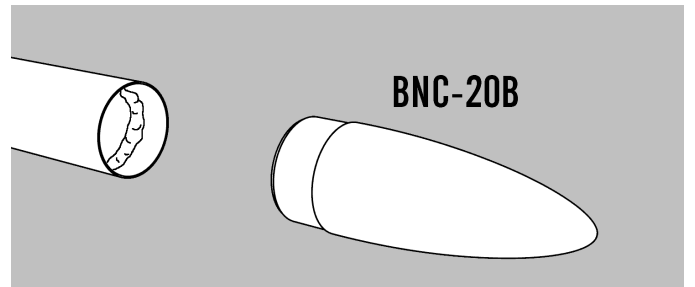

- ❑ **39.** Apply a bead of glue along the glider wing assembly joint. Attach the glider body tube with the end of the tube even with the trailing edge of the glider wings.

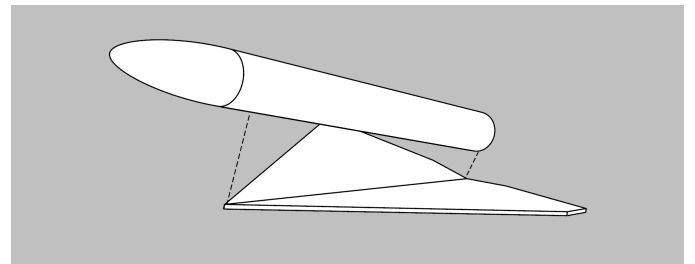

- ❑ **40.** Sand one end of the thick dowel (WD-201) so it has the same angle as the leading edge of the glider hold-down support (15). Glue the dowel so the front edges are aligned. Allow to dry.

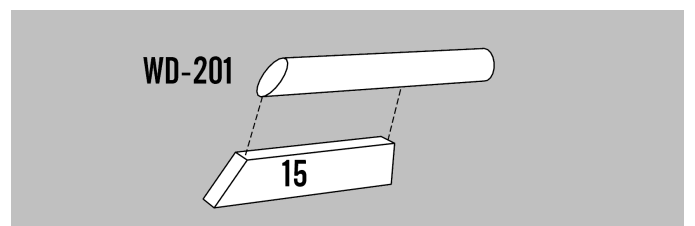

- ❑ **34.** Assemble chute using instructions printed on the canopy. Attach the chute to the screw eye.

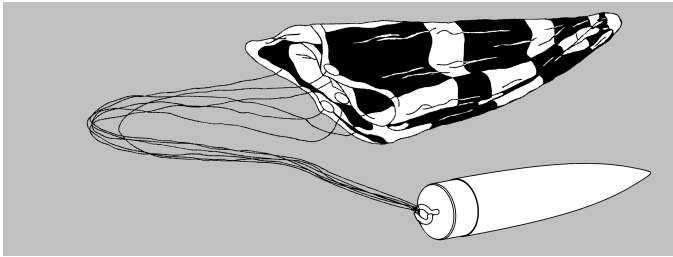

- ❑ **35.** Pull the Kevlar® thread out of the top of the main body tube. Tie the loose end to one end of the elastic cord. Tie the other end of the elastic cord to the screw eye. Put a drop of glue on both knots to keep them from untying.

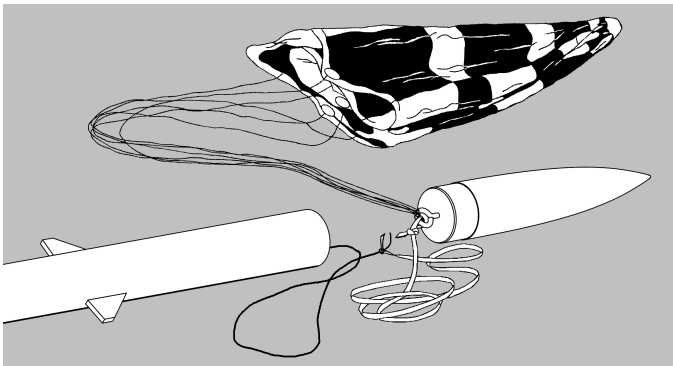

GLIDER ASSEMBLY

- ❑ **36.** Lay the glider body tube (BT-20D) on a flat surface. Place a sheet of wax paper over it to prevent the glue from sticking while the fins dry. Place a bead of glue on the root edge of one of the glider wings (14) and attach it to the other wing. As the joint starts to set, drape the assembly over the body tube and wax paper and support the ends while it dries.

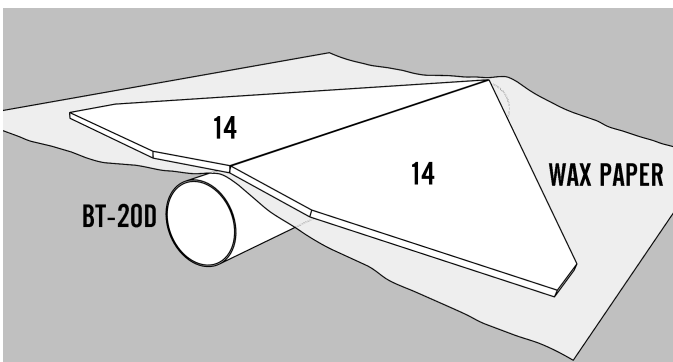

- ❑ **17.** When all the rings are in place and the knot is pulled up against the top ring, apply a fillet of glue around all the joints, being careful to keep the outside surfaces of both rings free of glue. Apply a bead of glue along the engine hook between the two rings. Allow to dry. Store the Kevlar® thread inside the engine tube until needed later.

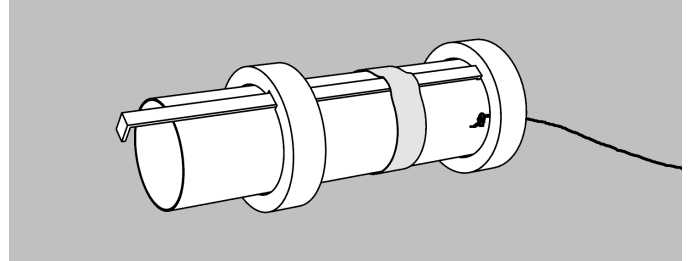

- ❑ **18.** Mark the engine mount 1/2" from the bottom end. Apply a bead of glue inside one end of the largest body tube (BT-50) about 1" from the end.

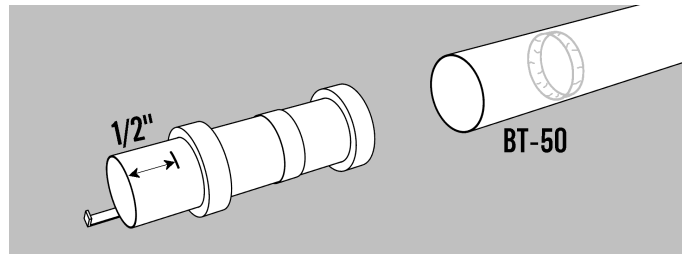

- ❑ **19.** Insert the top of the engine mount into the BT-50 and slide it forward until the mark is even with the end of the BT-50. Do not stop or the mount will "freeze" in the wrong place.

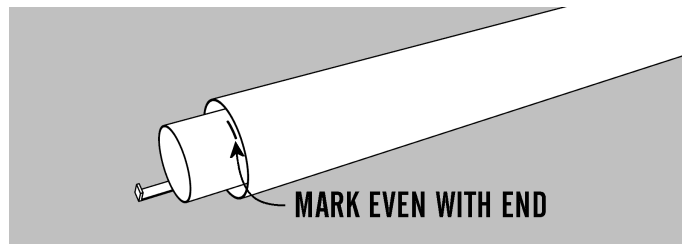

- ❑ **20.** Cut out the Booster Marking Guide from the pattern sheet. Wrap it around the body tube about 1/4" from the end nearest the engine mount. Align it so Arrow H points to the engine hook. Hold it in place with a small piece of tape. Place a mark at each arrow and write the corresponding letter near each mark for future reference.

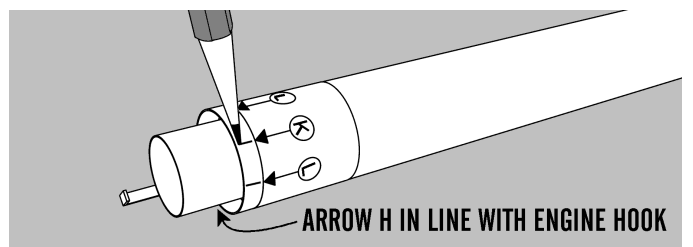

21. Using a door facing, drawer, or piece of angle molding, draw a line from each mark. Lines J, K, and L need to be 9" from the engine end and lines G and H need to be drawn for the entire length. Make sure the lines are parallel to the body tube.

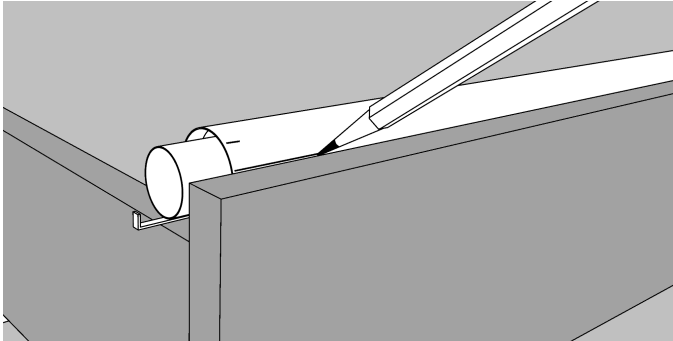

22. On line H (which is in line with the engine hook) place a mark 8-1/2" from the end and another mark 1/4" from the end. Cut two pieces from the launch lug (LL-122) and two pieces of the thin wood dowel (WD-103) to 5/8" each. Apply a bead of glue along one side of one of the launch lug pieces and glue one of the dowels in line with the launch lug. Repeat for the other assembly. When they are both dry, glue one assembly along Line H, with the dowel towards the tube and even with the 1/4" mark and one even with the 8-1/2" mark. Sight down the tube to make sure they are aligned with each other.

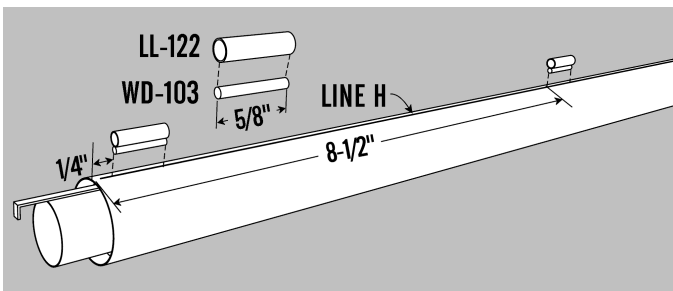

23. Attach one of the wing assemblies to Line G with the scramjet housing toward the engine hook as shown and even with the end of the body tube. Before the glue completely sets, attach the other wing assembly along the opposite Line G. Support the body tube vertically while the glue dries, checking for alignment.

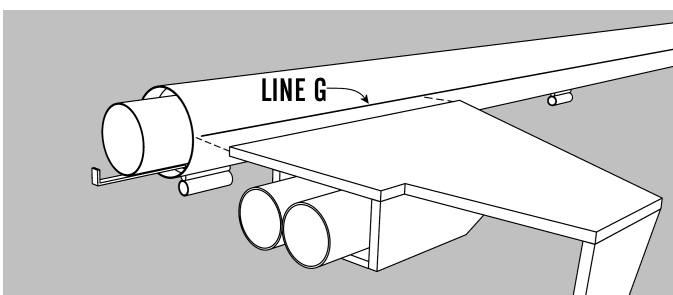

31. Apply glue to the root edge of one of the rudders (13) and attach it to the line corresponding to 13 drawn on the top of the wing even with the trailing edge. It should be perpendicular to the main wing. Repeat with the other rudder.

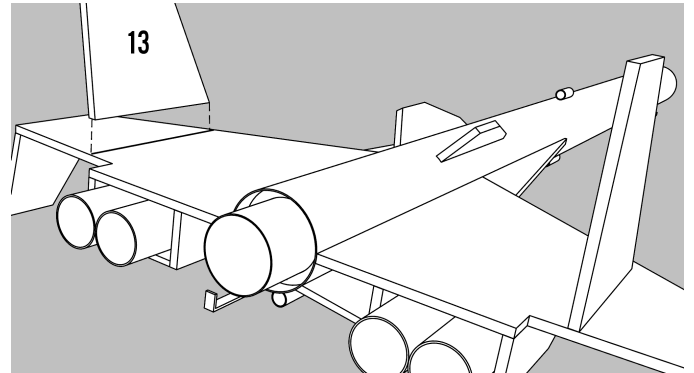

32. Apply glue to the root edge of one of the wing fences (12) and attach it to the line corresponding to 12 drawn on the top of the wing and even with the trailing edge. Note the orientation. It should be perpendicular to the main wing. Repeat with the other wing fence.

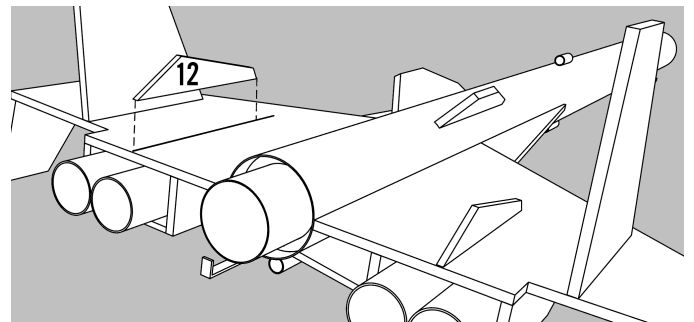

33. Insert the large nose cone (BNC-50Y) in the main body tube and check for proper fit. The nose cone should be snug to hold itself in alignment. If it is too loose, add masking tape. If it is too tight, sand the shoulder slightly. Twist the screw eye into the center of the base of the nose cone. Unscrew it and squirt glue into the hole. Reinstall the screw eye and wipe off any excess glue.

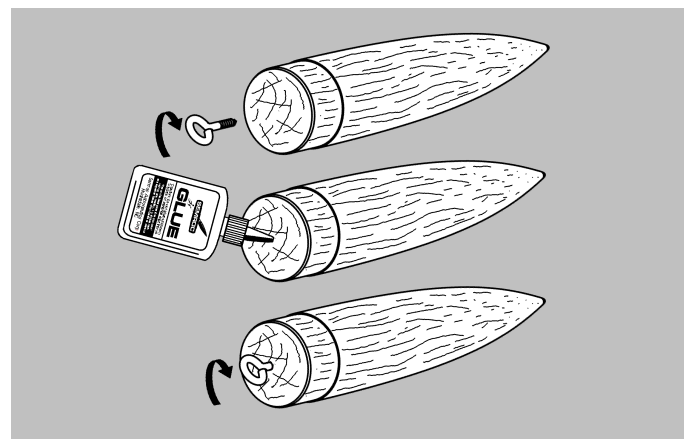

- ❑ **28.** Apply glue to the root edge of one of the ventral fins (10) and attach it to Line J and even with the end of the main body tube. It should be perpendicular to the body tube. Repeat with the other ventral fin.

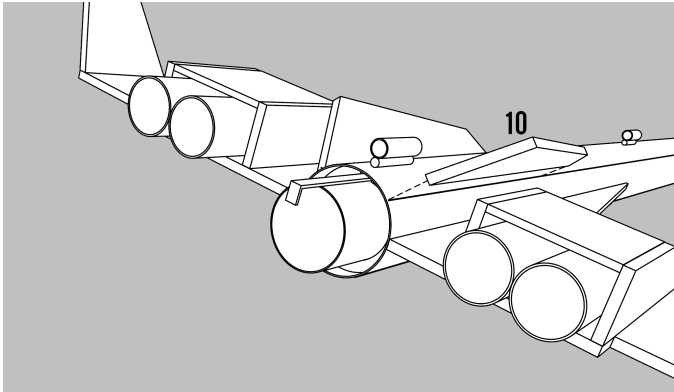

- ❑ **29.** Apply glue to the root edge of one of the glider supports (11) and attach it to Line L and 2-7/8" from the bottom end of the main body tube. It should be perpendicular to the body tube. Repeat with the other glider support.

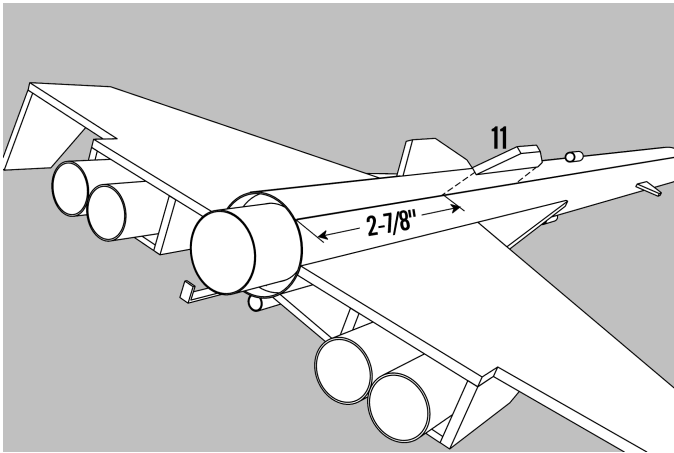

- ❑ **30.** Using the Booster Alignment Template, place a mark at the four arrows labeled 12 and 13 on the leading and trailing edge of each of the main fins. Using a ruler, connect the lines to use as attachment guides.

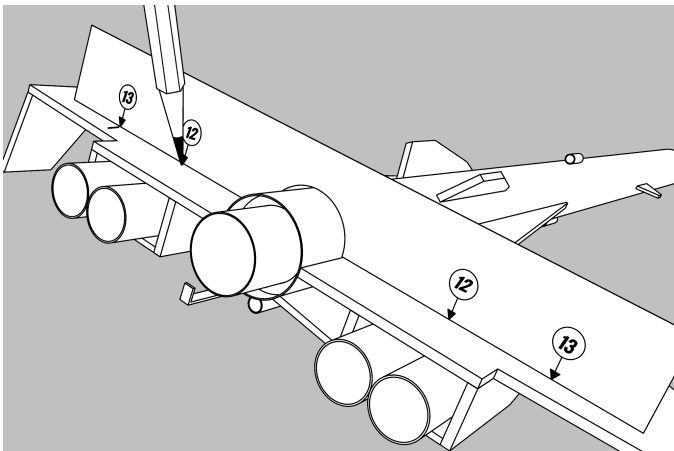

- ❑ **24.** While the glue is setting on the wings, cut out the Booster Wing Alignment Template from the pattern sheet. Use it as a guide to check for proper wing alignment.

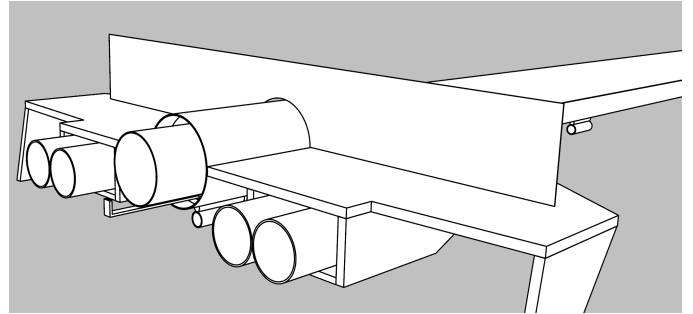

- ❑ **25.** Attach one of the wing fairings (8) to the leading edge of one of the wing assemblies and aligned on Line G. Round the leading edge of the main wing and fairing. Repeat with the other wing fairing.

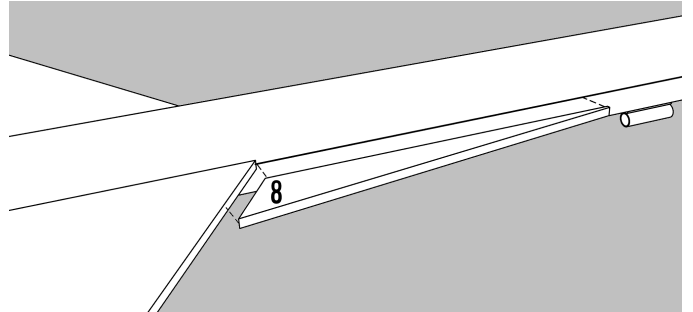

- ❑ **26.** Mark the booster body tube 4-1/2" from the top on Line G on both sides. Attach the canards on Line G with the top edge on the mark. Repeat for the other canard.

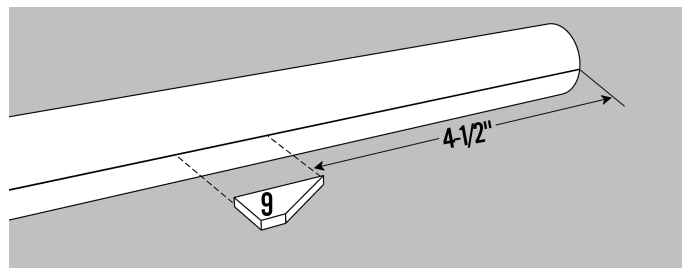

- ❑ **27.** Cut a piece of the launch lug (LL-122) to 1/2" long. Attach it to the top of the main body tube 9" from the top end along Line K. This launch lug does not need the wood dowel.

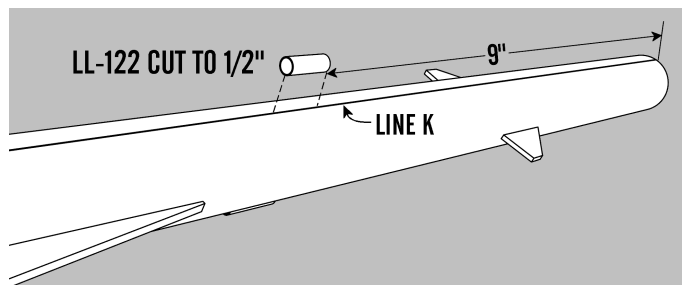

EXPLODED VIEW

Parts List

- A 1 Body Tube..... BT-50
- B 1 Body Tube..... BT-20D
- C 1 Body Tube..... BT-20J
- D 4 Body Tubes BT-5T
- E 1 Balsa Nose Cone..... BNC-50Y
- F 1 Balsa Nose Cone..... BNC-20B
- G 2 Adapter Rings AR-2050
- H 1 Paper Nose Block..... NB-20P
- I 1 Retaining Ring..... HR-20
- J 1 Wood Dowel WD-201
- K 1 Wood Dowel WD-103
- L 1 Screw Eye..... SE-2
- M 1 Elastic Cord EC-124
- N 1 Kevlar Cord SCK-18
- O 1 Launch Lug LL-122
- P 1 Engine Hook EH-28
- Q 1 Chute Pak..... CP-12RW
- R 1 Laser cut Fins (1-17) FV-66
- S 1 Decal (not shown)..... DKV-66
- T 1 Pattern Sheet (not shown) .. IKV-66P

