

About Centuri Engineering Company

Centuri Engineering Company was started in 1961 by Leroy (Lee) Piester in his garage while he was still in college in Phoenix, Arizona. With his wife, Betty, they built Centuri into one of the largest model rocket companies ever.

Centuri was known for its unusual and innovative designs, producing over 140 different kits with something for every model rocketeer. They also produced model rocket engines and pioneered the modern composite high powered engines with their Enerjet line.

Centuri Engineering was sold to Damon in the late 1960's and shared the same parent corporation with Estes Industries, the largest model rocket company in the world. The Centuri product line was kept separate from the Estes line until 1983. A few of the old kits have been reissued by Estes since then, but for the most part, Centuri Engineering Company lives today only in the dreams of the senior members of the model rocket community.

About the Satellite Killer™

The Satellite Killer was released in 1980 by Centuri Engineering Company along with the Red-Eye as its enemy satellite. Both of these models were a part of their "War in Space" series. Since these were done in the final days of Centuri as a separate company from Estes Industries, there were no later entries. Inspired by the cold war "Star Wars" proposal, the "War in Space" never happened, but the designers at Centuri were dreaming of what it would be like if it did. It was released as Catalog Number 5345 and had an introductory price of \$7.00.

The Retro-Repro™ Satellite Killer™ is updated with laser-cut fiber fins. The original foil decals are changed to waterslide for ease of use and durability. A Kevlar cord is added for a more reliable shock mount. Most of the rest of the model is faithful to the original design.

What is a Retro-Repro?

A Retro-Repro™ is a retro reproduction of an out-of-production model rocket kit. It is a close approximation of a full scale model of an early historically significant model rocket kit from one of the many companies that pioneered the hobby over the past half century. A Retro-Repro™ is not a true clone or identical copy of the original. It incorporates improvements using modern technology, while keeping the flavor and build appeal of the early kits.

July 18, 2013

Copyright © 2013 Semroc Astronautics Corporation
Box 1271 Knightdale, NC 27545 (919) 266-1977

SATELLITE KILLER™

1980
Retro-Repro

CLASSIC DESIGN

EASY TO BUILD

**COLORFUL
WATERSLIDE DECAL**

**WAR
IN SPACE™**

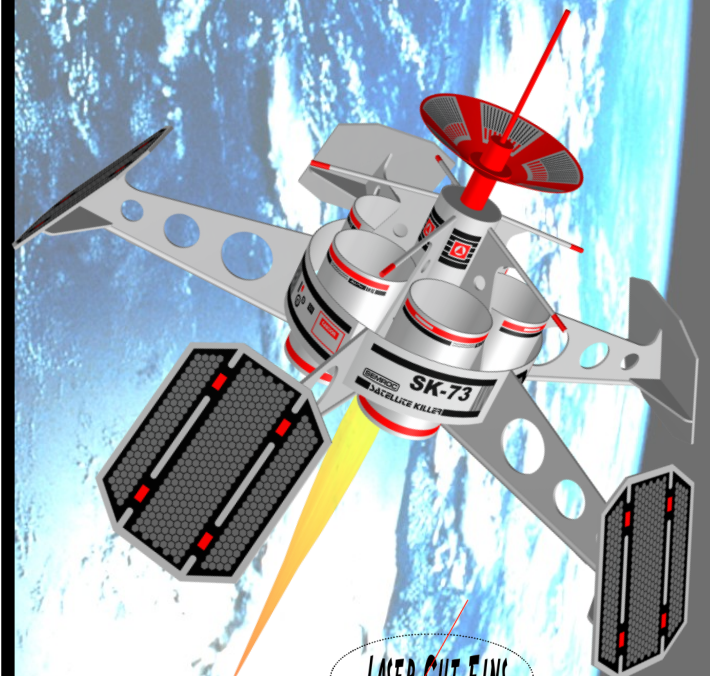

**FLYING MODEL
ROCKET KIT**



Made in the U.S.A by Semroc Astronautics Corporation - Knightdale, N.C. 27545

SATELLITE KILLER™ Kit No. KV-73

Specifications	Engine	Approx. Altitude
Body Diameter .998" (2.5 cm)	C6-3	125'
Length 6.5" (16.5 cm)		
Fin Span 12.3" (31.1 cm)		
Net Weight 3.1 oz. (88.0 g)		

PARACHUTE RECOVERY

Parts List

EXPLODED VIEW

- A 1 Body Tube.....ST-930
- B 1 Body Tube.....BT-101A
- C 5 Body TubesST-1320
- D 1 Body Tube.....BT-3XW
- E 1 Body TubesST-730E
- F 1 Laser Cut Set.....FV-73
- G 1 Ring Set.....CR-79EH2
- H 1 Engine Hook.....EH-28
- I 1 Thrust Ring.....TR-7
- J 1 Elastic CordEC-124
- K 1 Kevlar® Thread.....SCK-12
- L 1 Launch Lug.....LL-120
- M 5 Wood Dowels.....WD-1020
- N 1 Wood DowelWD-1040
- O 5 Wood Dowels.....WD-2048
- P 1 Chute PakCP-14
- Q 1 Ring Set.....CR-KV-73
- R 1 Centering RingCR-79
- S 1 Antenna Shroud....IKV-73S
- T 1 Tyvek® StripIKV-73T
- U 1 Decal Set
(Not Shown).....DKV-73

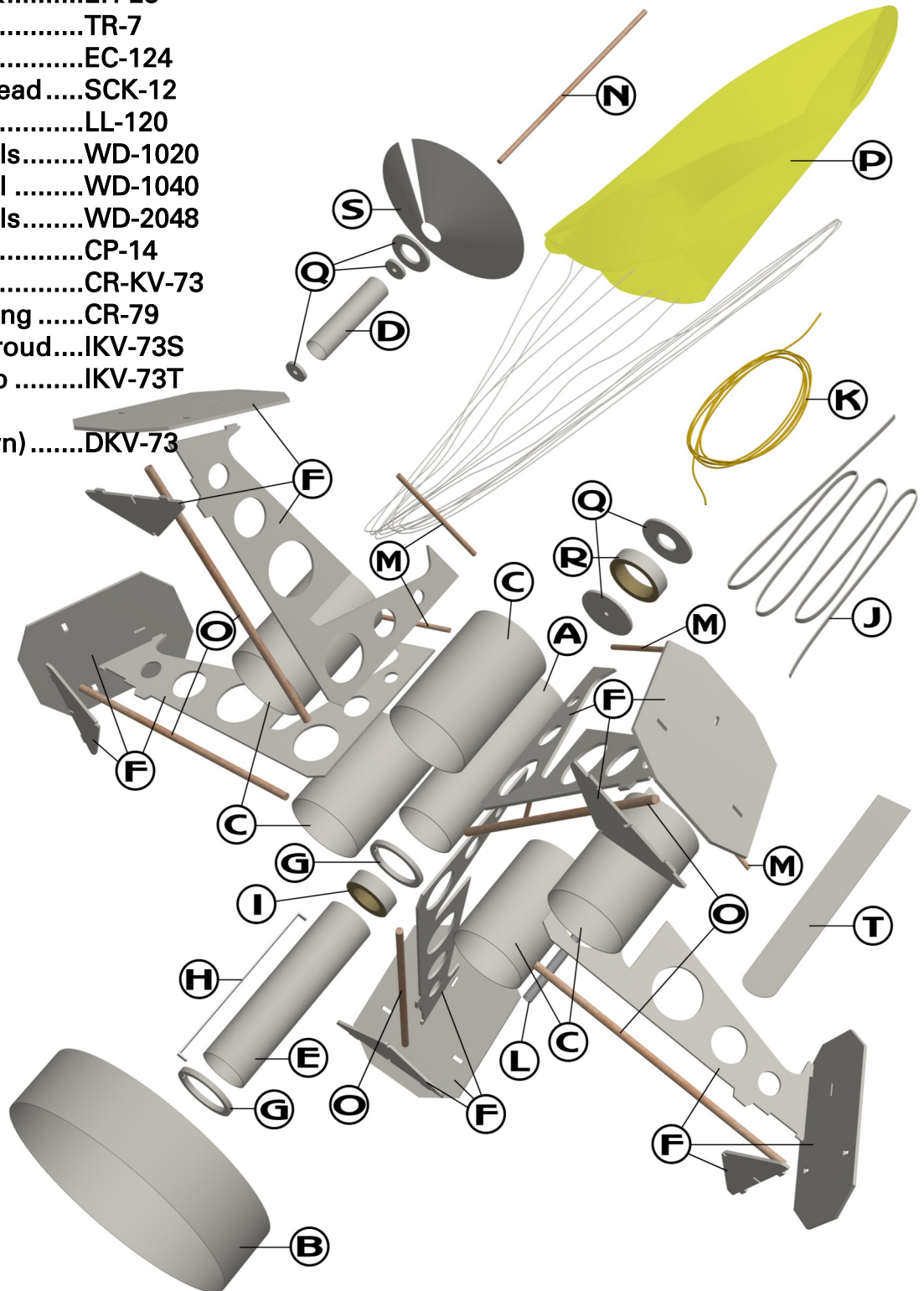

BEFORE YOU START!

Make sure you have all the parts included in this kit that are listed in the Parts List in these instructions. In addition to the parts included in this kit, you will also need the tools and materials listed below. Read the entire instructions before beginning to assemble your rocket. When you are thoroughly familiar with these instructions, begin construction. Read each step and study the accompanying drawings. Check off each step as it is completed. In each step, test-fit the parts together before applying any glue. It is sometimes necessary to sand lightly or build-up some parts to obtain a precision fit. If you are uncertain of the location of some parts, refer to the exploded view to the left. It is important that you always ensure that you have adequate glue joints.

TOOLS

In addition to the parts supplied, you will need the following tools to assemble and finish this kit. Masking tape and wax paper are also required.



ASSEMBLY

❑ 1. These instructions are presented in a logical order to help you put your Satellite Killer™ together quickly and efficiently. Check off each step as you complete it and we hope you enjoy putting this kit together.

ENGINE MOUNT

❑ 2. Bend the engine hook (EH-28) slightly so it forms a slight bow in the direction shown.



❑ 3. Mark the engine tube (ST-730E) 3/4" from the end opposite the pre-punched slit.

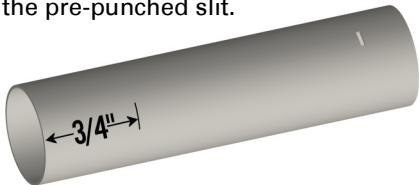

❑ 4. Insert one end of the engine hook into the slit in the engine tube.

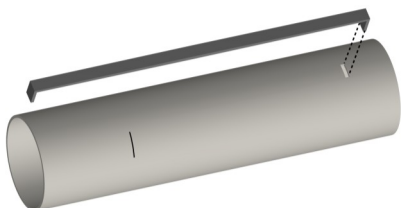

❑ 5. Slide one of the two thin centering rings (CR-79EH2) over the bottom of the engine tube, with the small flat notch aligned with the engine hook and even with the mark on the tube. Slide the other thin centering ring over the top of the tube and just over the end of the engine hook.

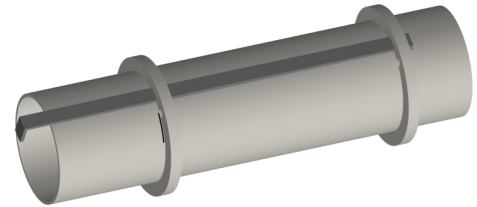

❑ 6. Insert one end of the Kevlar Cord (SCK-12) into the small notch in the lower centering ring. Pull the thread through and along the side of the engine hook until it almost reaches the top ring. Apply a bead of glue around the joint formed at the intersection of both rings with the engine tube and along the portion of the cord between the two rings..

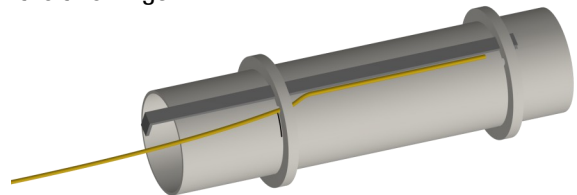

❑ 7. Wrap masking tape around the engine tube centered along its length. Run a bead of glue over the masking tape. Allow to dry.

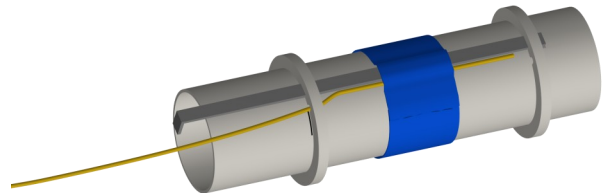

❑ 8. Glue the thrust ring (TR-7) into the top of the engine tube and against the top of the engine hook. Allow to dry.

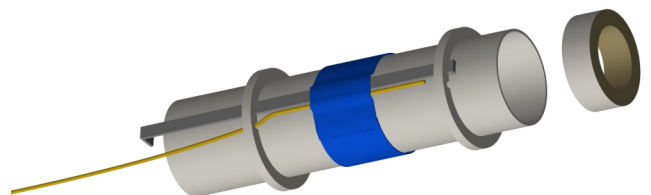

MAIN BODY TUBE

❑ 9. Carefully remove the two largest rings from the ring set (CR-KV-73). Glue one to each side of the centering ring (CR-79). Allow to dry.

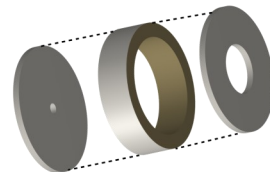

- ❑ 10. Place a bead of glue inside the main body tube (ST-930). Insert the ring assembly into the body tube with the small hole first until the top ring is even with the top of the main body tube.

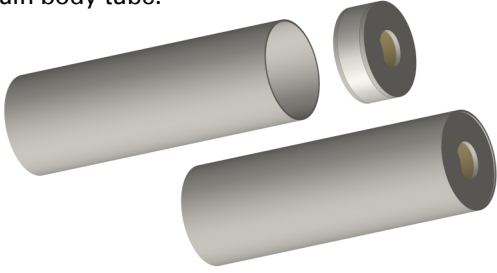

MARK TUBES

- ❑ 11. Stand the main body tube assembly on the small circle and make the five position marks on the sides of the tube designated by the marks. Find a convenient channel or groove such as a partially open drawer, a door jamb (as shown,) or a piece of molding. Using the channel, extend all lines the entire length of the tube. Mark the large outer support ring using the large circle with the five positions. Extend all five lines the length of the ring.

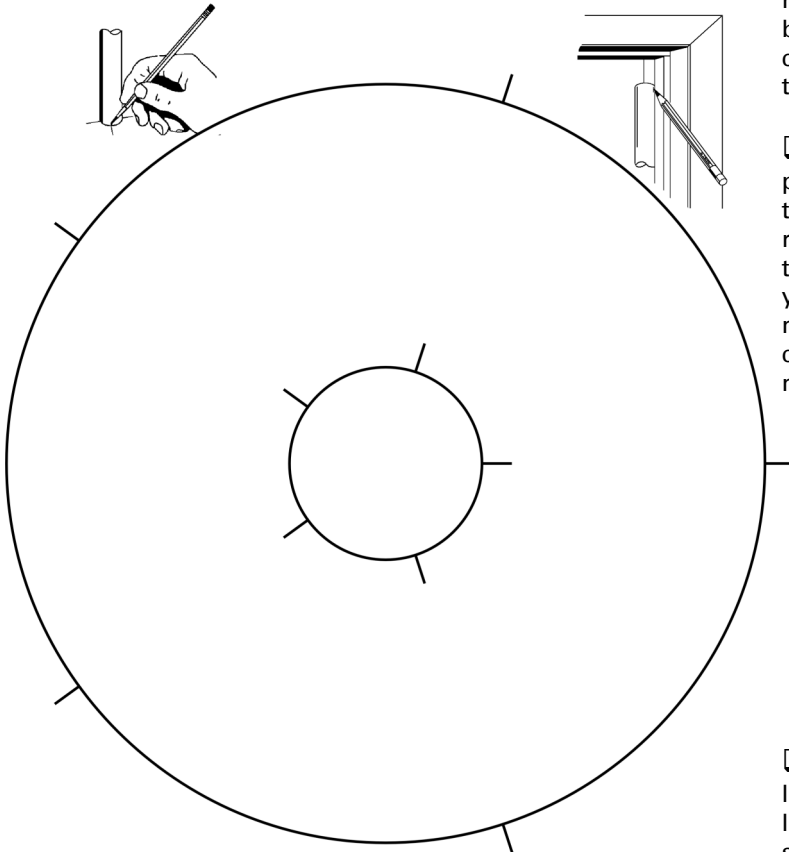

ELASTIC CORD

- ❑ 12. Locate one of the five canister tubes (ST-1320). Cut two 1/4" wide slits, one 1/2" from the top of the tube and another 1/4" below the first slit. Push the section between the slits in slightly and insert one end of the elastic cord (EC-124) through the top of the tube and then through the

slot formed. Pull the cord about 1/2" through the slot. Press from the inside of the tube and push the area as flat as possible. Apply a bead of glue on both sides of the slotted area along the elastic cord. Smooth the glue on both sides of the tube. Store the cord inside the tube for now.

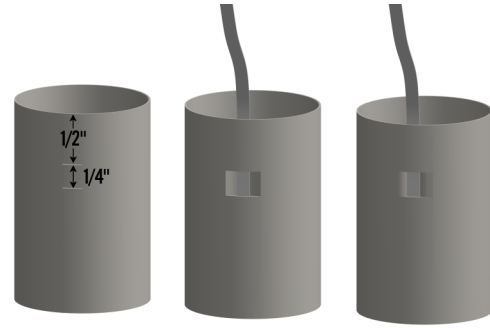

LEGS

- ❑ 13. Carefully remove all the laser-cut parts from the five fiber sheets (FV-73). If necessary, use your hobby knife to help remove the parts. Punch out all the inner circles from the five legs. They will not be used. Do not remove the small "foot" from the bottom of each leg. For best results, lightly sand each edge and then apply a thin coat of cyanoacrylate (CA) glue along each edge to seal the laminations. Allow to dry.

- ❑ 14. Apply glue to the root edge of one of the legs and position it along one of the lines drawn on the main body tube and even with the bottom of the tube opposite the ring assembly. Remove the leg, set it aside and allow it to almost dry, apply additional glue, and reposition. If you follow these instructions, the legs will not require much additional work to keep them aligned. Allow to set, checking carefully to make sure it is parallel with the main body tube.

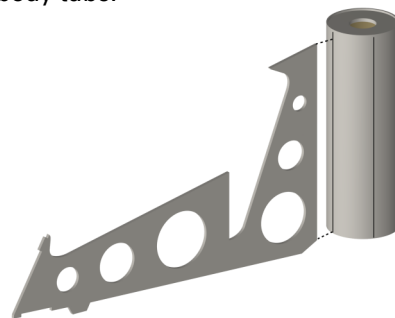

- ❑ 15. Repeat with the other four legs. Make sure each leg is straight out from the main body tube and on the line drawn. As the legs dry, stand the assembly on a flat surface and make sure each leg touches at the point nearest the bottom of the main body and that the "foot" near the tip of the leg is flat on the surface.

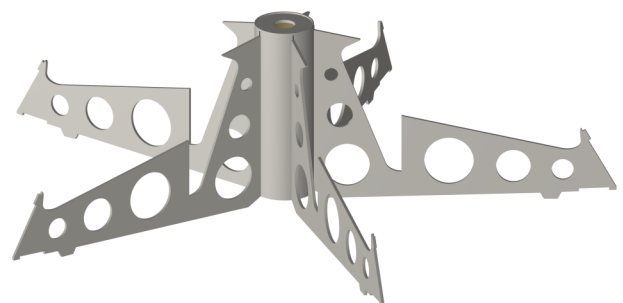

□ 16. Insert the outer support ring (BT-101A) over the assembly and touching the outer root edge of each leg. Line up the legs and the lines drawn on the ring. Add a fillet of glue along each leg at the intersection with the ring.

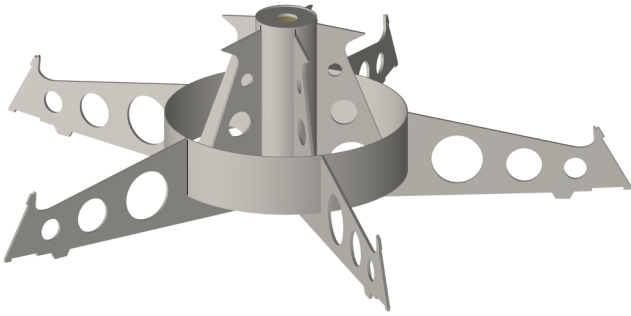

□ 17. Place wax paper under the assembly and make sure it is still flat. Locate the five canister tubes (ST-1320), including the one that has the elastic cord installed. Check for fit of one of the canister tubes, between two legs and against the main central body tube. Note where they touch and add a bead of glue to each area that they contact. Replace the canister tube against the legs and main body tube and flush with the flat surface. Place the slot of the tube containing the elastic cord towards the main body tube so it does not show.

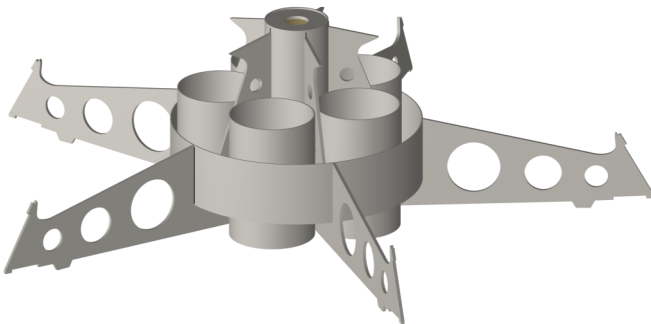

□ 18. After the assembly is completely dry, turn it over and break off each of the five "feet" from the legs. Sand lightly if the area left is not flat.

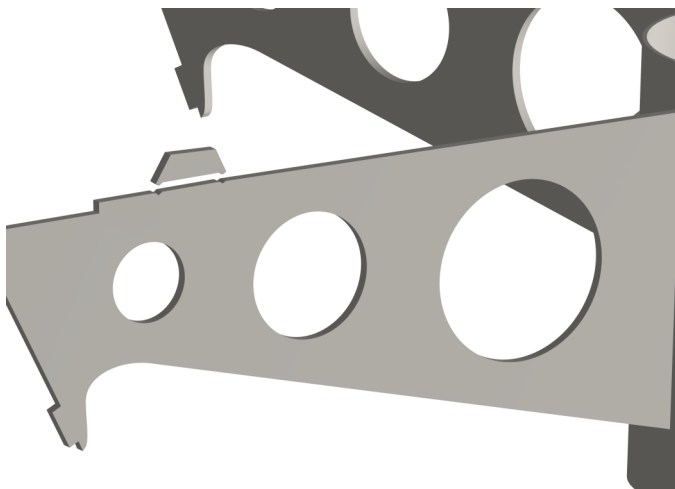

□ 19. Locate one of the panel braces removed from the fiber sheet (FV-73). Apply a line of glue at its center and between the two central notches. Glue it in place on one of the legs as shown. Allow to dry and repeat with the other four panel braces.

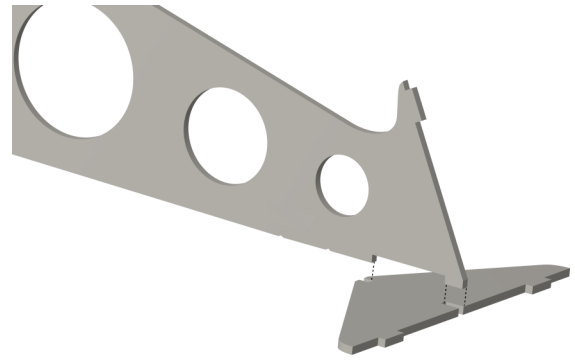

□ 20. Locate one of the flat solar panels removed from the fiber sheet (FV-73). Apply a line of glue to the tabs on the leg and panel braces and along the point they will contact the panels. Glue the panel in place with the three tabs aligned with the three corresponding slots. Allow the assembly to dry and repeat with the other four panels.

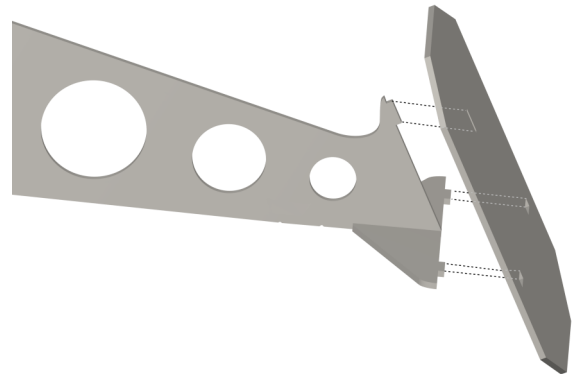

□ 21. Turn the assembly upside down and wait for all the joints to completely dry.

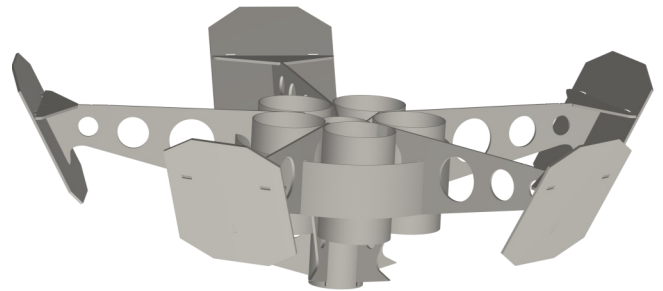

□ 22. Locate the five longest dowels (WD-2048). Apply a bead of glue along the bottom of one of the legs. Glue the dowel to the edge of the leg, butted against the solar panel. Repeat with the other four dowels.

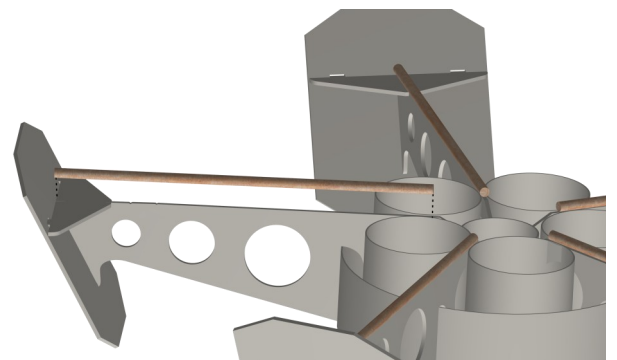

- ❑ **23.** Locate the five shortest dowels (WD-1020). Apply a bead of glue along the top edge of one of the legs. Glue the dowel to the edge of the leg, butted against the main body tube. Repeat with the other four dowels.

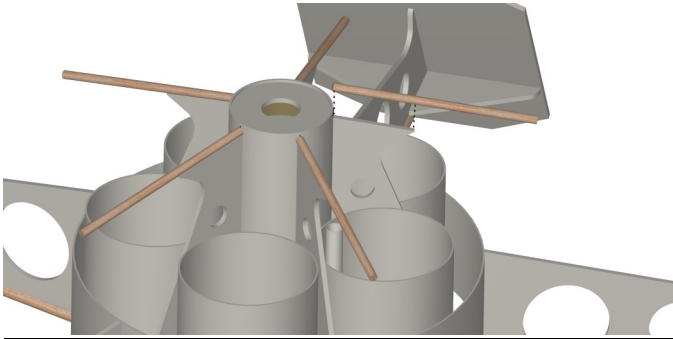

LAUNCH LUG

- ❑ **24.** Apply a bead of glue to the launch lug (LL-120) and glue it inside one of the canisters that does not have the elastic cord on the side closest to the main body tube and parallel with the canister tube. Allow to dry.

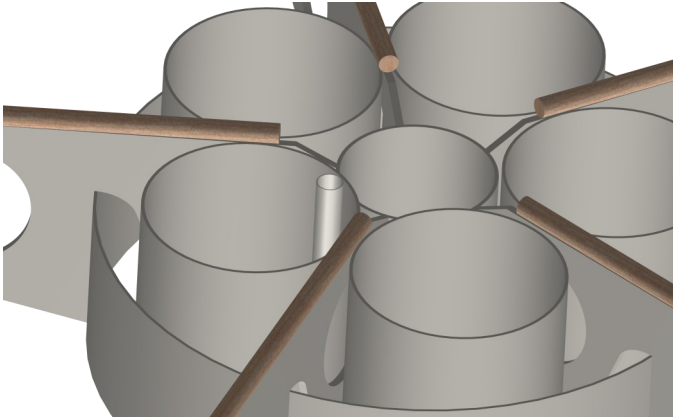

PARACHUTE RETAINER

- ❑ **25.** Apply a bead of glue to one end of the Tyvek strip (IKV-73T) for a distance of about 1/2". Glue it inside the canister tube containing the elastic cord away from the main body tube as shown. The rest of the strip will hang below the canister tube. Run a fillet of glue all around the strip where it contacts the canister tube. This will have some high force at ejection time. Allow it to dry.

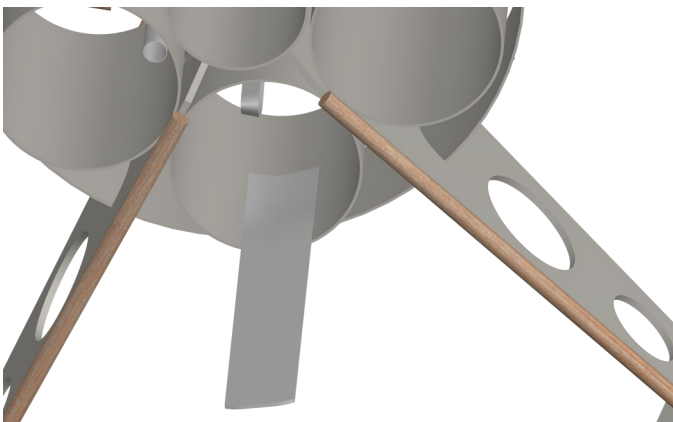

DECORATIVE ANTENNA

- ❑ **26.** Cut out the antenna dish from the shroud sheet (IKV-73S). Apply a thin coat of glue to the tab. Form the shroud into a cone, overlapping the opposite end over the tab. Hold in place until the glue sets.

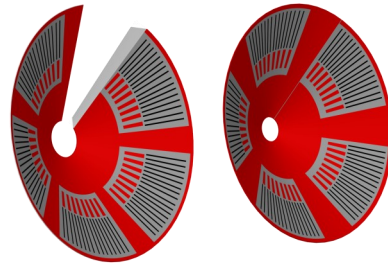

- ❑ **27.** Carefully remove the remaining rings from the ring set (CR-KV-73). Apply a small bead of glue inside each end of the antenna tube (BT-3XW). Place one of the small rings inside each end of the tube. Use the remaining dowel or a pencil to help position the rings. Allow to dry.

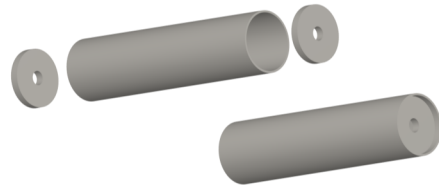

- ❑ **28.** Insert the remaining dowel (WD-1040) through both holes until about 1/2" is exposed on the bottom end. Run a fillet of glue around the dowel and ring at each end.

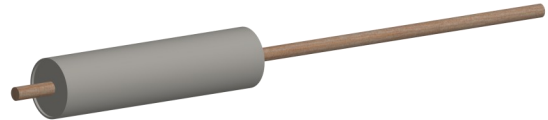

- ❑ **29.** Apply a bead of glue around the antenna tube 1/2" from the top end. Push the antenna shroud from the bottom until it contacts the glue.

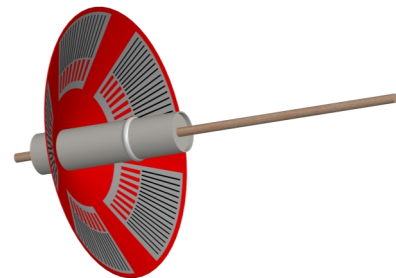

- ❑ **30.** Slide the remaining disk over the top of the antenna tube and against the antenna shroud. Run a bead of glue around the disc and tube joint.

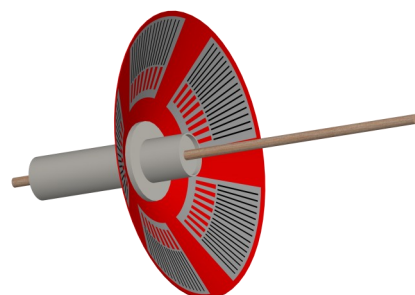

APPLY FILLETS

□ 31. After all joints are completely dry, run a small bead of glue along both sides of each joint formed between the legs and body tubes, legs and panels and panel braces, and along the 10 wood dowel-leg joints. Using your forefinger, smooth the glue into fillets. Allow this assembly to dry in a vertical position.

FINAL ASSEMBLY

□ 32. Tie the free end of the Kevlar® cord to one end of the elastic cord (EC-124) using an overhand knot.

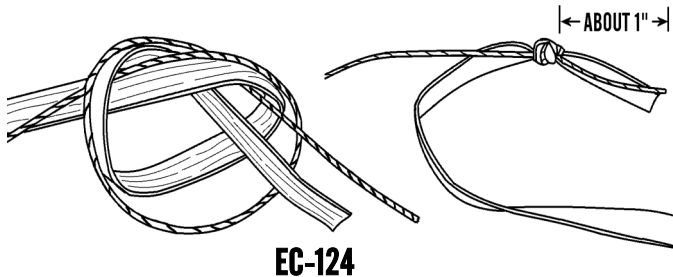

□ 33. Assemble the chute (CP-14) using the instructions provided with it. Pull the lines tight on the chute and make sure they are all of equal length. Attach the chute to the elastic cord near the knot just formed with the Kevlar® cord. Put a drop of glue on the joint to keep the lines from moving.

FINISHING

□ 34. Prepare the wood surfaces for a smooth professional looking finish. Fill the wood grain with balsa fillercoat or sanding sealer. When dry, sand with fine sandpaper. Repeat until smooth.

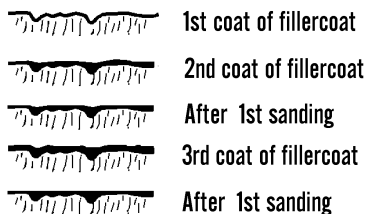

□ 35. Spray the model with an enamel primer. Paint the model (except the decorative antenna) with a light gray final color. Spray painting your model with a fast-drying enamel will produce the best results. PATIENCE...is the most important ingredient. Use several thin coats, allowing each coat to completely dry before the next coat. Start each spray a few inches above the model and end a few inches below the model. Keep the can about 12" away and use quick light coats. The final coat can be a little heavier to give the model a glossy wet-looking finish.

□ 36. The decorative antenna should be painted by hand. Everything except the inner printed area of the shroud should be painted with gloss red enamel. Paint the tips of each of the five dowels at the top of each leg should also be painted gloss red 1/2" from the end.

□ 37. After the paint has dried, decals should be applied. The decals supplied with the Satellite Killer™ are water-slide decals. Each decal should be cut separately from the sheet. Use the photos below for suggested placement. Dip each decal in a small dish of water that has a drop of detergent. It will take about 30 seconds before the decal is loose enough to apply. Slide the decal in place and use the paper backing to work the bubbles out. Repeat for all the decals.

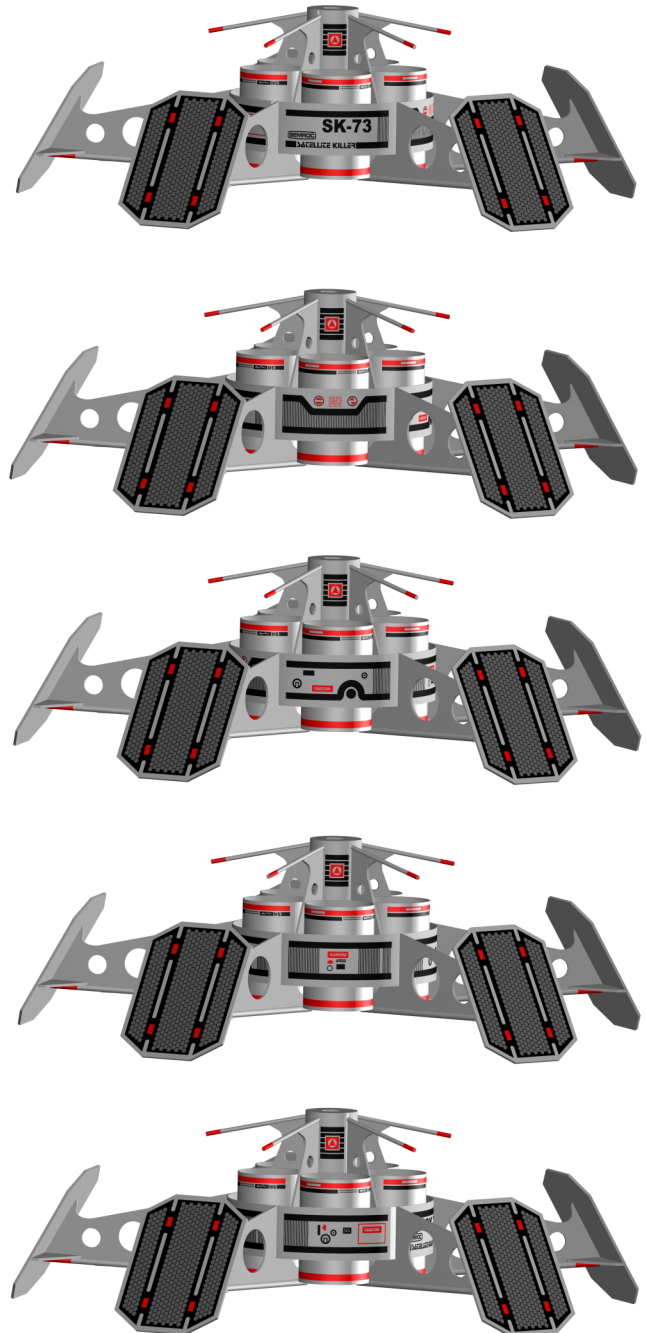

FLIGHT PREPPING

❑ **38.** The Satellite Killer™ takes a little more preparation than most standard rockets. Fold the parachute and roll the elastic cord and Kevlar® cord around the chute. Leave about 4" of the cord free between the chute and engine mount. Insert the parachute and cords into the canister tube with the Tyvek strip hanging outward. Then fold the Tyvek strip into the main central body tube (ST-930) as far as possible.

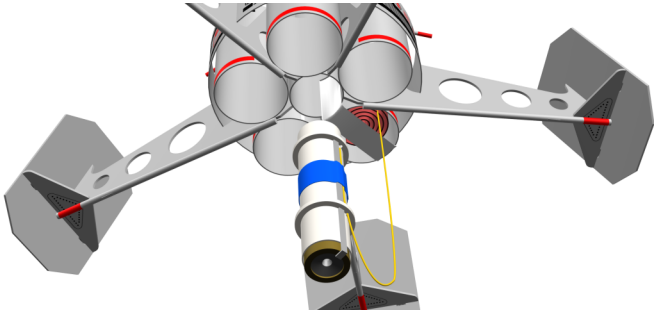

❑ **39.** Insert the engine mount into the main body tube, capturing the Tyvek strip with the centering rings. This will keep the parachute from deploying during launch and will allow the parachute to pull free when the engine mount is ejected. Tuck the remaining Kevlar® cord into the canister. If the engine mount is loose, apply one or more strips of masking tape along the end of the Tyvek strip that goes inside the main body tube.

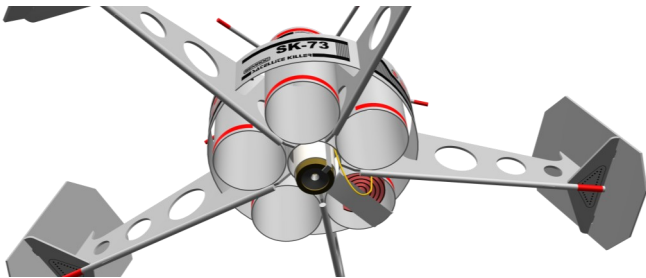

❑ **40.** Do not launch the Satellite Killer™ with the decorative antenna in place!

❑ **41.** Mounting the engine: Insert the engine and make sure the engine hook keeps the engine in snugly. **The only currently approved engine is the C6-3.** The hook may be slightly bent to make sure the engine is retained.

❑ **42.** Refer to the model rocket engine manufacturer's instructions to complete the engine prepping. Different engines have different igniters and methods of hooking them up to the launch controllers.

❑ **43.** Carefully check all parts of your rocket before each flight as a part of your pre-flight checklist. Launch the Satellite Killer™ from a 1/8" diameter by 36" long launch rod. **As with all similar high drag, short models, do not launch unless it is calm and only in a vertical position.**

❑ **44.** After each flight, promptly remove the spent engine casing and dispose of properly.