

# DER V-1.5™

**DOWNSCALE OF A CLASSIC DESIGN**

**FUN TO BUILD & FLY**

**BALSA NOSE CONE & FINS**

FLYING MODEL ROCKET KIT



Made in the U.S.A by Semroc Astronautics Corporation - Knightdale, N.C. 27545

## DER V-1.5™ Kit No. KA-36

Specifications	Engine	Approx. Altitude
Body Diameter 1.325" (3.4 cm)	A8-3	300'
Length 12.1" (30.9 cm)	B6-4	600'
Fin Span 5.3" (13.5 cm)	C6-5	1150'
Net Weight 0.8 oz. (23.0 g)		

### PARACHUTE RECOVERY

## About the Der V-1.5™

The classic Der V-3 was released by Estes Industries in their 1987 catalog. It was most likely designed by Wayne Kellner as a larger takeoff of his highly popular Der Red Max done a few years earlier based on the BT-60. This version is a half scale model of the original BT-80 based Der V-3, so it is, naturally, the Der V-1.5.

The Der V-1.5™ includes laser-cut balsa fins and a balsa nose cone. It has a standard 18mm engine mount for popular engines. The engine mount uses Kevlar thread for better retention. A waterslide decal is provided to decorate it with some of the original zany pseudo-German markings. A two color parachute is included for recovery.

## About Semroc Astronautics

Semroc Astronautics Corporation was started by Carl McLawhorn in his college dorm at North Carolina State University in November, 1967. Convincing a small group of investors in his home town of Ayden, North Carolina to invest in a small corporation, the company was re-incorporated as Semroc Astronautics Corporation on December 31, 1969.

Semroc produced a full line of model rocket kits and engines. At its peak, Semroc had twenty-five full time employees working at two facilities. One was for research and development, printing, shipping, and administration. The other was outside town and handled all production and model rocket engine manufacturing. For several years, Semroc was successful selling model rocket kits, supplies, and engines by mail-order and in hobby shops. In early 1971, Semroc became insolvent and had to close its doors.

After 31 years of dreams and preparations, Semroc Astronautics Corporation was reincorporated on April 2, 2002 with a strong commitment to helping put the fun back into model rocketry.

## EXPLODED VIEW

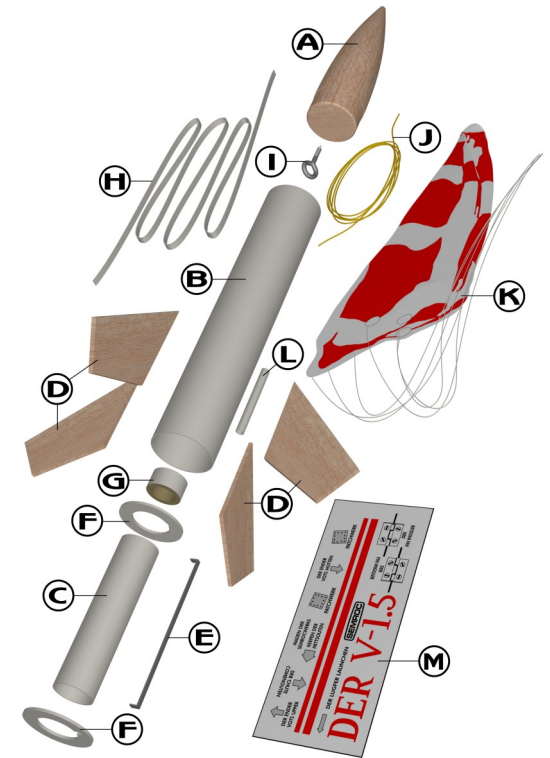

## PARTS LIST

A	1	Balsa Nose Cone .....	BNC-55KP
B	1	Body Tube .....	BT-55K
C	1	Body Tube .....	ST-730E
D	1	Laser-cut Fin Set.....	FA-36
E	1	Engine Hook .....	EH-28
F	1	Centering Ring Set.....	CR-7-55EH
G	1	Thrust Ring .....	TR-7
H	1	Elastic Cord .....	EC-124
I	1	Screw Eye .....	SE-1
J	1	Kevlar Cord .....	SCK-12
K	1	Chute Pak.....	CP-12RW
L	1	Launch Lug .....	LL-115
M	1	Decal .....	DKA-36

October 15, 2012

Copyright © 2012 Semroc Astronautics Corporation  
Box 1271 Knightdale, NC 27545 (919) 266-1977

## TOOLS

In addition to the parts supplied, you will need the following tools to assemble and finish this kit. Masking tape is also required.



## ASSEMBLY

❑ 1. These instructions are presented in a logical order to help you put your Der V-1.5™ together quickly and efficiently. Check off each step as you complete it and we hope you enjoy putting this kit together.

## FIN PREPARATION

❑ 2. Lightly sand each side of the laser-cut fin sheet (FA-36). Carefully push the laser-cut fins from their sheet. Start at one point on each fin and slowly and gently work around the fin.

❑ 3. Stack all the fins in a set. Line the set of fins up squarely and sand the fins back and forth over some fine sandpaper to get rid of the hold-in tabs as shown below.

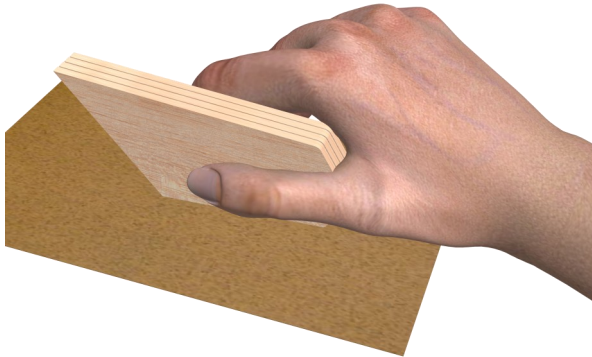

❑ 4. Round all the edges of each fin, except the root edges. Leave them flat. Repeat for all four fins. The root edges will be glued to the body tube.

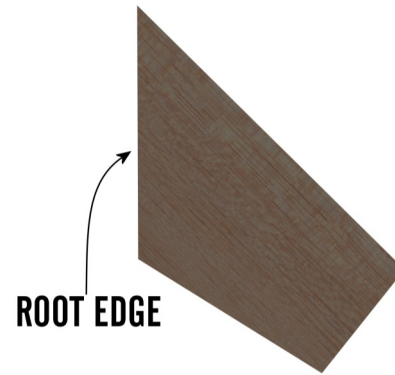

## MARK TUBE

❑ 5. Stand the large body tube (BT-55K) on the fin guide below and make the fin position marks on the sides of the tube. Find a convenient channel or groove such as a partially open drawer, a door jamb (as shown,) or a piece of molding. Using the channel, extend the marks 3" from the bottom of the tube.

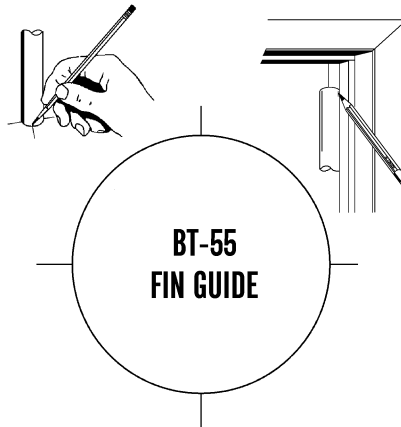

## ENGINE MOUNT

❑ 6. Bend the engine hook (EH-28) slightly so it forms a slight bow in the direction shown.



❑ 7. Tie a loop in one end of the yellow Kevlar® cord (SCK-12). Pull knot tight.



❑ 8. Insert one end of the engine hook (EH-28) through the loop in the Kevlar cord and into the pre-punched engine tube (ST-730E).

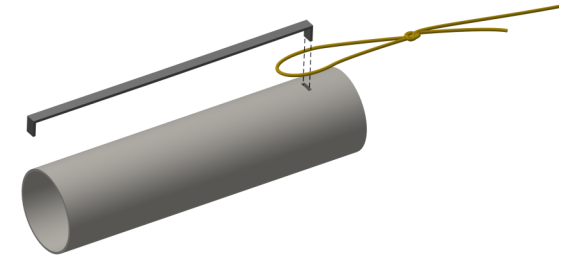

❑ 9. Carefully remove the two centering rings from the laser-cut set (CR-7-55EH). Select the one with the small notch and align the notch over the engine hook. Slide it from the bottom of the engine tube until it is against the end of the engine hook and against the yellow Kevlar® cord.

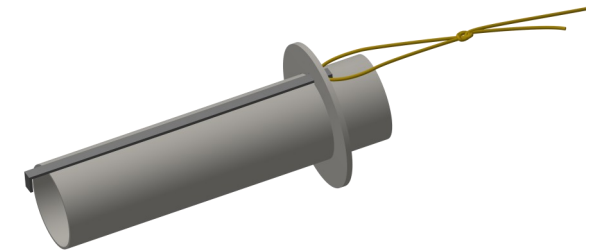

❑ 10. Wrap masking tape around the center of the engine tube to hold the engine hook in place and centered along its length. Run a bead of glue over the masking tape and along the engine hook between the tape and the ring. Allow to dry.

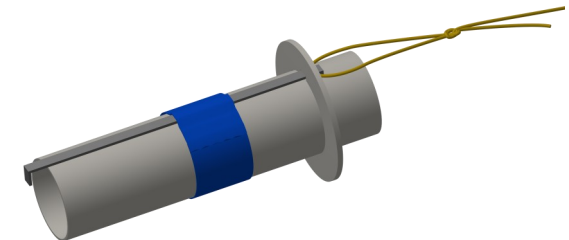

❑ 11. Select the remaining centering ring that has the wider notch. Align the notch over the engine hook and slide it from the bottom of the engine tube until it is 1/2" from the bottom of the engine tube. Apply a bead of glue around both sides of both centering rings and against the engine tube. Keep glue away from the outer edges of both rings and from the notch in the lower ring. Make sure the engine hook moves freely. Allow to dry in an upright position.

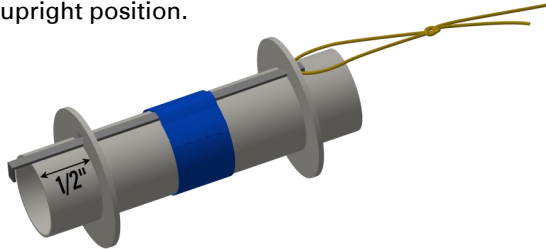

❑ 12. Glue the thrust ring (TR-7) in place inside the top of the engine tube and against the top of the engine hook. When completely dry, pull the yellow shock cord back through the engine tube and out the back of the engine mount.

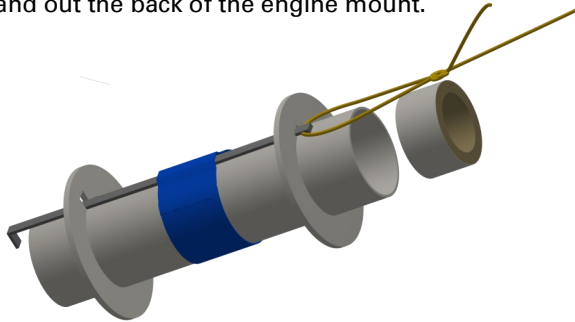

## ATTACH FINS

❑ 13. Apply glue to the root edge of one of the fins and position it along one of the lines drawn for the fins on the side of the main body tube (BT-55K) and even from the bottom. Remove the fin, set it aside and allow it to almost dry, apply additional glue, and reposition. Repeat for the other three fins. If you follow these instructions, the fins will not require much additional work to keep them aligned. Allow the fins to completely dry, checking carefully to make sure they are parallel with the main body tube.

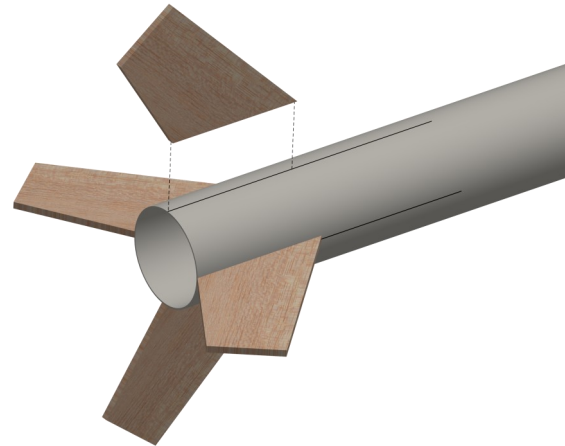

## ATTACH MOUNT

❑ 14. Apply a thick bead of glue inside the aft end of the main body tube and on the top side of the bottom ring, keeping glue away from the engine hook slot. Insert the engine mount assembly with the thrust ring end first into the main body tube until the lower ring is recessed slightly in the main tube and the engine hook is centered between two of the fins. Do not stop until it is in the correct place. Allow to dry completely in a vertical position.

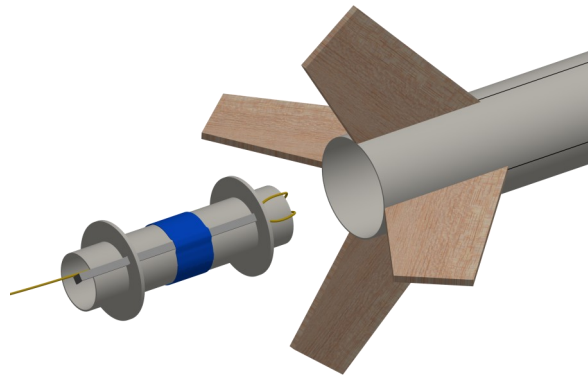

## LAUNCH LUG

❑ 15. Apply a bead of glue to the launch lug (LL-115) and apply it to the main body tube, centered between two fins and even with the bottom of the tube. Sight from one end to make sure it is parallel with the fins.

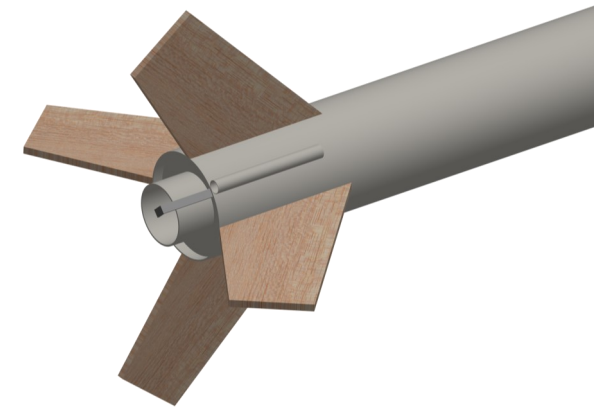

## APPLY FILLETS

❑ 16. After the fins are completely dry, run a small bead of glue along both sides of each fin-body tube joint. Using your forefinger, smooth the glue into fillets. Apply a fillet of glue on each side of the launch lugs. Allow this assembly to dry in a vertical position.

## NOSE CONE

❑ 17. Insert the nose cone (BNC-55KP) in the main body tube and check for proper fit. The nose cone should be snug to hold itself in alignment. If it is too loose, add masking tape. If it is too tight, sand the shoulder slightly.

❑ 18. Screw the screw eye (SE-1) into the base of the nose cone, remove and fill the hole with glue. Reinsert the screw into the nose cone until the eye is flush with the base of the nose cone.

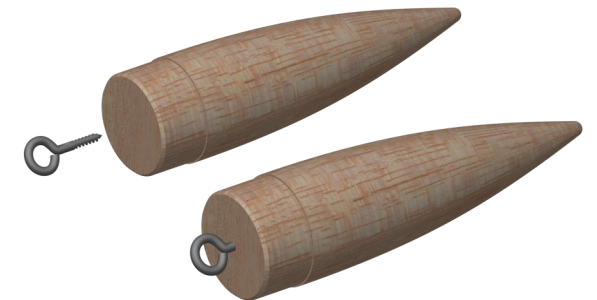

## FINAL ASSEMBLY

- ❑ **19.** Tie the free end of the Kevlar® cord to one end of the elastic cord (**EC-124**) using an overhand knot. Pull the elastic cord and Kevlar cord back through the main body tube and out the top of the tube.

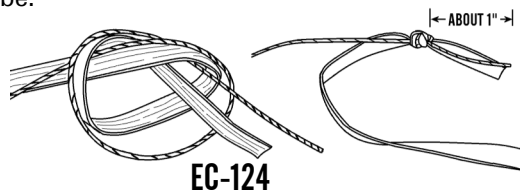

- ❑ **20.** Assemble the chute (**CP-12**) using the instructions provided with it. Pull the lines tight on the chute and make sure they are all of equal length. Attach the chute by tying them to the screw eye. Put a drop of glue on the joint to keep the lines from moving. Attach the free end of the elastic cord to the screw eye. Put a drop of glue on that joint as well.

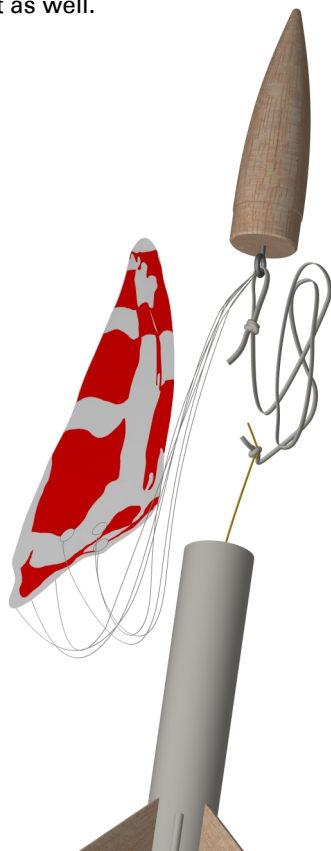

## FINISHING

- ❑ **21.** When all the fillets have dried, prepare balsa surfaces for a smooth professional looking finish. Round the edges of the fins, then fill the wood grain with balsa fillercoat or sanding sealer. When dry, sand with fine sandpaper. Repeat until smooth.



1st coat of fillercoat



2nd coat of fillercoat



After 1st sanding



3rd coat of fillercoat



After 1st sanding

- ❑ **22.** After all balsa surfaces have been prepared, wipe off all balsa dust with a dry cloth. First spray the model with an enamel primer. Choose a high visibility color like white for the final color. Spray painting your model with a fast-drying enamel will produce the best results. PATIENCE... is the most important ingredient. Use several thin coats, allowing each coat to completely dry before the next coat. Start each spray a few inches above the model and end a few inches below the model. Keep the can about 12" away and use quick light coats. The final coat can be a little heavier to give the model a glossy wet-looking finish.

- ❑ **23.** After the paint has dried, decals should be applied. The decals supplied with the Der V-1.5™ are waterslide decals. Each decal should be cut separately from the sheet. Use the cover photo for suggested placement. Dip each decal in a small dish of water that has a drop of detergent. It will take about 30 seconds before the decal is loose enough to apply. Slide the decal in place and use the paper backing to work the bubbles out. Repeat for all the decals.

## FLIGHT PREPPING

- ❑ **24.** Mounting the engine: Insert the engine and make sure the engine hook keeps the engine in snugly. The hook may be slightly bent to make sure the engine is retained.

- ❑ **25.** Apply a few sheets of recovery wadding in the top of the main body tube. Fold the chute and pack it and the shock cord on top of the recovery wadding. Slide the nose cone into place, making sure it does not pinch the shock cord or chute.

- ❑ **26.** Refer to the model rocket engine manufacturer's instructions to complete the engine prepping. Different engines have different igniters and methods of hooking them up to the launch controllers.

- ❑ **27.** Carefully check all parts of your rocket before each flight as a part of your pre-flight checklist. Launch the Der V-1.5™ from a 1/8" diameter by 36" long launch rod.

- ❑ **28.** After each flight, promptly remove the spent engine casing and dispose of properly.