

About Semroc Astronautics Corporation

Semroc Astronautics Corporation was started by Carl McLawhorn in his college dorm at North Carolina State University in November, 1967. Convincing a small group of investors in his home town of Ayden, North Carolina to invest in a small corporation, the company was re-incorporated as Semroc Astronautics Corporation on December 31, 1969.

Semroc produced a full line of model rocket kits and engines. At its peak, Semroc had twenty-five full time employees working at two facilities. One was for research and development, printing, shipping, and administration. The other was outside town and handled all production and model rocket engine manufacturing. For several years, Semroc was successful selling model rocket kits, supplies, and engines by mail-order and in hobby shops. In early 1971, Semroc became insolvent and had to close its doors.

After 31 years of dreams and preparations, Semroc Astronautics Corporation was reincorporated on April 2, 2002 with a strong commitment to helping put the fun back into model rocketry.

About the IQSY Tomahawk™

The IQSY Tomahawk™ was designed by Sandia Corporation using a Thiokol Chemical Corporation TE-416 Tomahawk rocket motor for flights during the International Quiet Sun Year (IQSY), 1964-1965. The first test was at the Atomic Energy Commission's Tonopah Test Range on June 12, 1963 in Nevada. Two subsequent test rounds were failures, but the fourth, final round was a success. The IQSY Tomahawk was never flown as a single stage again, but was launched in numerous Nike Tomahawk flights.

About Deci-Scale™

Semroc's new line of Deci-Scale™ models includes 1/10 (deci) scale kits of many of the early sounding rockets. The Deci-Scale™ kits are intended to be fun to build, providing the beginning average modeler with all the parts needed to build a reasonably close scale model. An advanced scale modeler will find the included parts are very close to the exact scale that are needed for much closer models.

The Deci-scale™ line was inspired by G. Harry Stine who said, "the best beginner's scale model I've ever found is the Thiokol-NASA I.Q.S.Y Tomahawk." He designed a 1/10 scale model for Centuri Engineering Company that was very popular and sold for many years. As he and others have found, 1/10 scale is almost perfect for many of the favorite rockets and missiles of the early days of space flight.

August 4, 2009

Copyright © 2009 Semroc Astronautics Corporation
Box 1271 Knightdale, NC 27545 (919) 266-1977

IQSY Tomahawk

**1/10 SEMI-SCALE
MODEL**

**HISTORICAL
SOUNDING
ROCKET**

**FUN TO BUILD
AND FLY**

**FLYING MODEL
ROCKET KIT**

DECI/SCALE

LASER CUT FINS

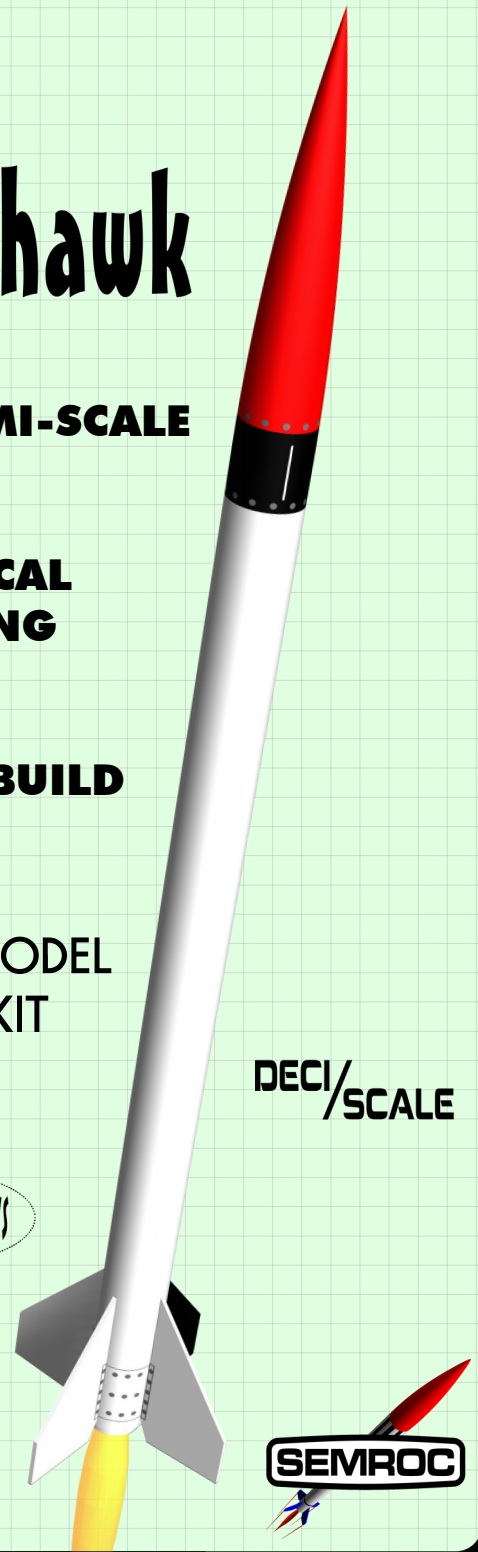

Made in the U.S.A by Semroc Astronautics Corporation - Knightdale, N.C. 27545

IQSY TOMAHAWK™ Kit No. KD-2

Specifications	Engine	Approx. Altitude
Body Diameter	A8-3	250'
Length	B6-6	600'
Fin Span	C6-7	1300'
Net Weight		

PARACHUTE RECOVERY

Parts List

EXPLODED VIEW

- A 1 Balsa Nose Cone... BC-8460
- B 1 Body Tube..... ST-860
- C 1 Body Tube..... ST-890
- D 1 Body Tube..... ST-730E
- E 1 Tubing Couplers ... HTC-8
- F 1 Laser Cut Fins FD-2
- G 1 Thrust Ring TR-7
- H 1 Engine Hook EH-28
- I 2 Centering Rings CR-78
- J 1 Screw Eye SE-12
- K 1 Elastic Cord..... EC-124
- L 1 Launch Lugs LL-2A
- M 1 Chute Pak..... CP-12BY
- N 1 Decal DKD-2

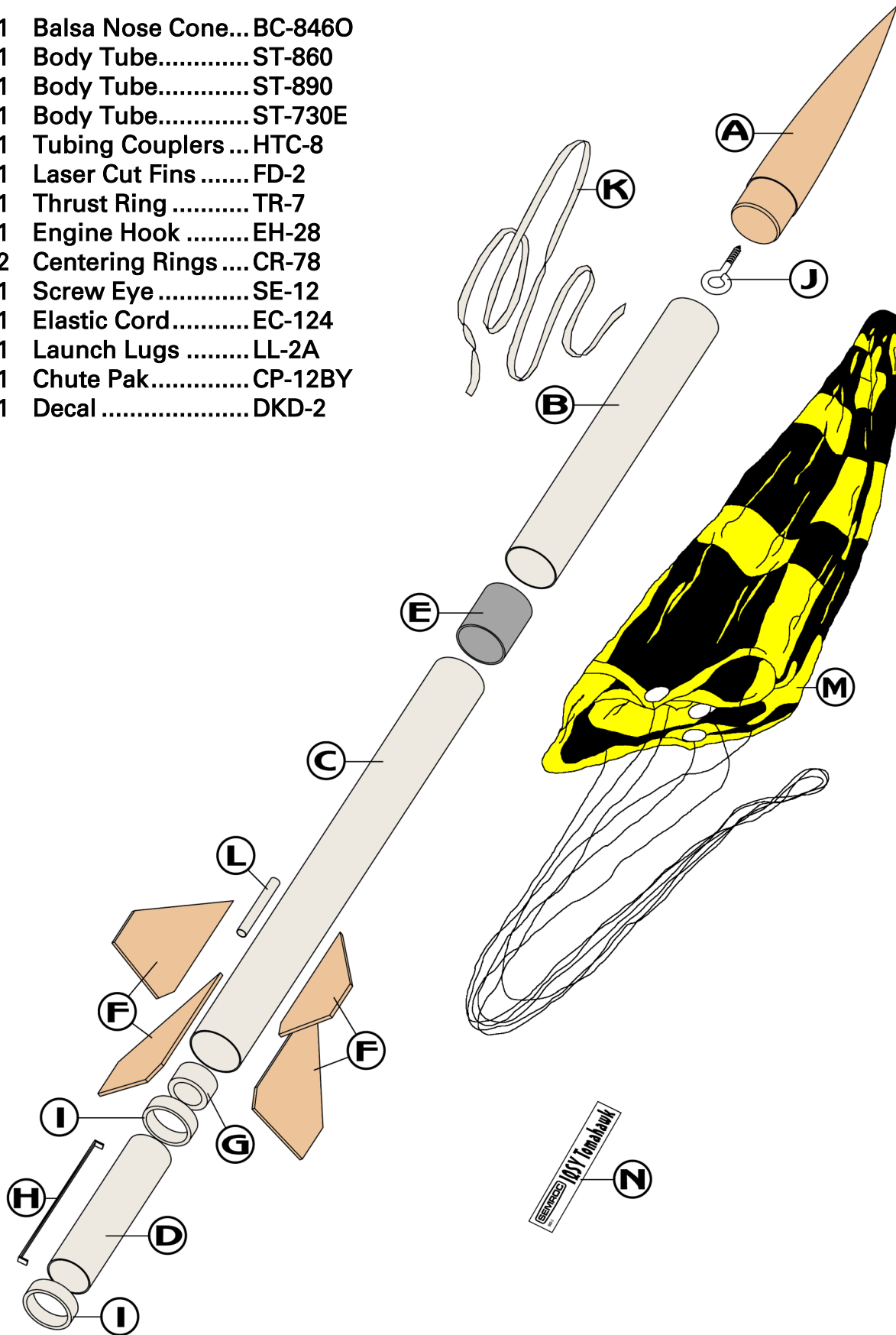

BEFORE YOU START!

Make sure you have all the parts included in this kit that are listed in the Parts List. In addition to the parts included in this kit, you will also need the tools and materials listed below. Read the entire instructions before beginning to assemble your rocket. When you are thoroughly familiar with these instructions, begin construction. Read each step and study the accompanying drawings. Check off each step as it is completed. In each step, test-fit the parts together before applying any glue. It is sometimes necessary to sand lightly or build-up some parts to obtain a precision fit. If you are uncertain of the location of some parts, refer to the exploded view. It is important that you always ensure that you have adequate glue joints.

TOOLS

In addition to the parts supplied, you will need the following tools to assemble and finish this kit. Masking tape is also needed.



ASSEMBLY

- 1. These instructions are presented in a logical order to help you put your IQSY Tomahawk™ together quickly and efficiently. Check off each step as you complete it and we hope you enjoy putting this kit together.

FIN PREPARATION

- 2. Lightly sand each side of the laser-cut basswood fin sheet (FD-2). Carefully push the laser-cut fins from the sheet. Start at one point on each fin and slowly and gently work around the fin.

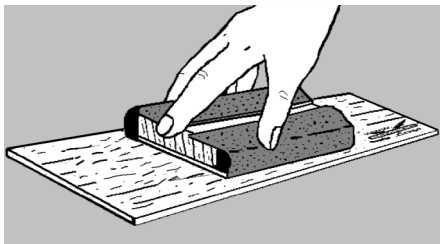

- 3. Stack all four fins in a group. Line the group up squarely and sand the fins back and forth over some fine sandpaper to get rid of the hold-in tabs as shown below.

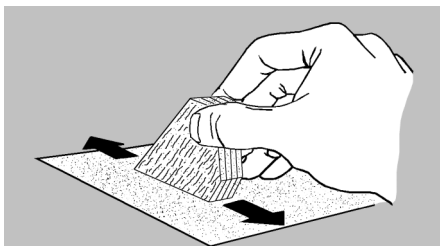

- 4. Sand a taper on each leading edge .21" wide and leave all the tip and root edges flat. For scale fins, sand to .05" thick.

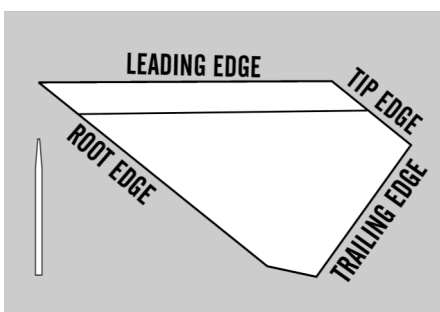

ENGINE MOUNT

- 5. Bend the engine hook (EH-28) slightly so it forms a slight bow in the direction shown.

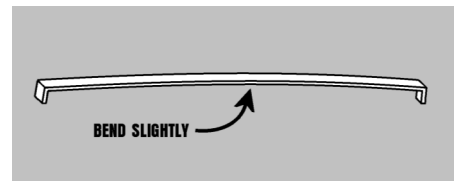

- 6. Insert one end of the engine hook (EH-28) into the pre-punched engine tube (ST-730E).

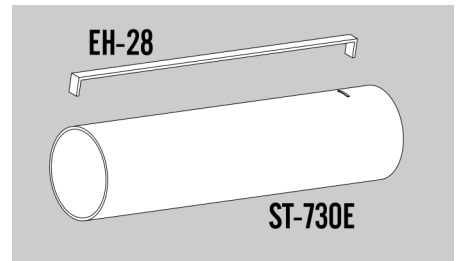

- 7. Apply a small bead of glue around the inside of the engine tube nearest the punched end. Slide the thrust ring (TR-7) into the tube and against the engine hook.

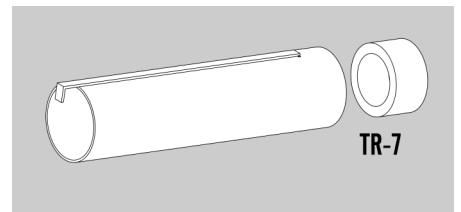

- 8. Slide one of the centering rings (CR-78) over the engine tube until it is about 1/2" from the slotted end. Apply a bead of glue around each end of the joint between the ring and engine tube, keeping glue off the outside surface of the centering ring. Allow to dry.

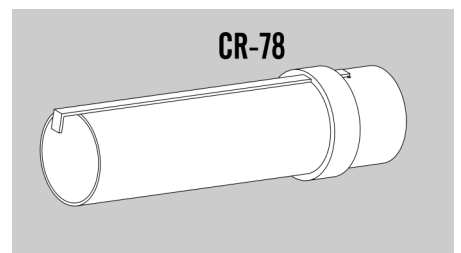

❑ 9. Slide the remaining centering ring (CR-78) over the bottom end of the engine tube. Space it 3/4" from the bottom of the engine tube. Apply a bead of glue around both sides of the centering ring.

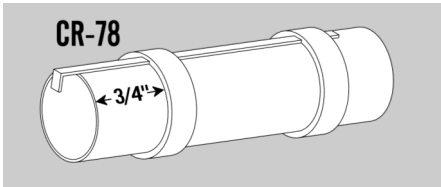

BODY TUBE

❑ 10. Stand the longest body tube (ST-890) on the fin guide below and make the fin position marks on the sides of the tube. Find a convenient channel or groove such as a partially open drawer, a door jamb (as shown,) or a piece of molding. Using the channel, extend the marks the full length of the tube to provide lines for aligning the fins.

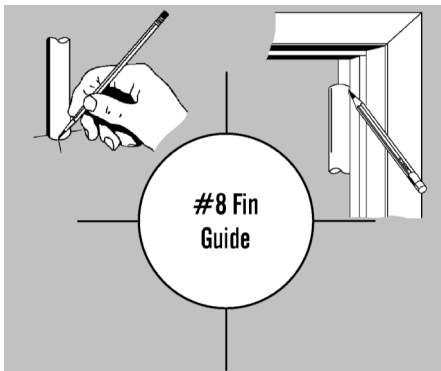

❑ 11. Mark the tubing coupler (HTC-8) in the center, 1/2" from each end. Thread the elastic cord (EC-124) around the coupler as shown. Feed the longest end of the cord through the short tube (ST-860) and out the top. Apply a bead of glue inside the shorter body tube (ST-860) and insert the coupler halfway into the tube, also capturing the short end of the elastic inside the tube. Apply a bead of glue inside the longer tube and insert the other half of the coupler inside it. If the elastic cord tries to bunch or catch, pull the longer exposed end *gently*. Do not wait for it to dry!

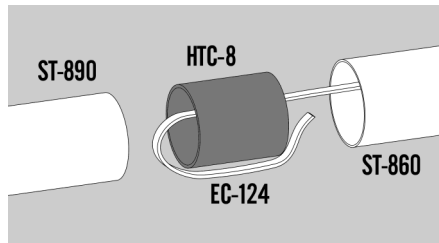

❑ 12. Roll the assembly on a smooth flat surface while the glue sets to get the tubes aligned. Make sure the joint is smooth and the two tubes are touching. Wipe any excess glue and wait for the joint to dry completely. Make sure the elastic is still hanging out of the top of the body tube.

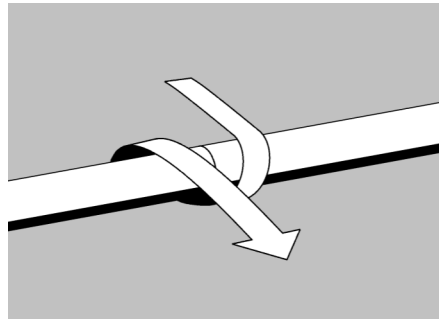

INSERT MOUNT

❑ 13. Check the engine mount for fit in the lower (marked) body tube. If it has rough edges or excessive glue, sand lightly until it fits into the body tube. Apply a heavy bead around the inside of the body tube.

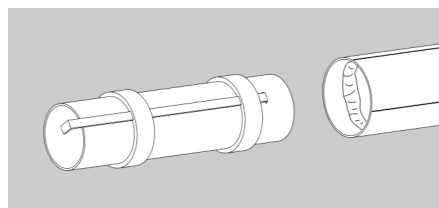

❑ 14. Quickly and smoothly push the engine mount into the marked end of the body tube until about 1/8" is extending from of the body tube and the **engine hook is centered between two of the lines**. Do not stop once you start inserting the mount or it might freeze in place too soon.

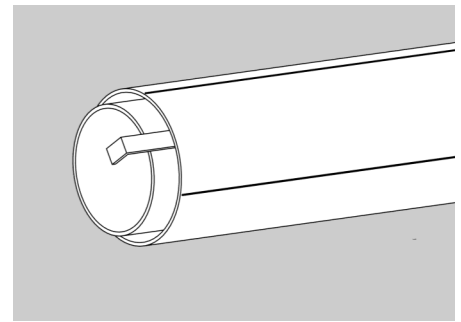

ATTACH FINS

❑ 15. Apply glue to the root edge of one of the fins and position it along one of the lines drawn for the fins on the side of the body tube and a little over 1/8" (.150") from the end of the tube. Remove, allow to almost dry, apply additional glue, and reposition. Repeat for the other three fins. Allow to dry in an upright position, checking frequently to make sure they remain aligned.

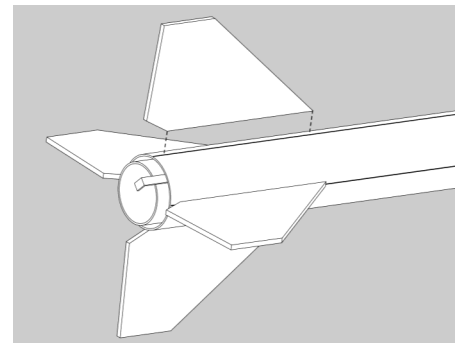

❑ 16. After the fin assembly is completely dry, run a very small bead of glue along both sides of each fin-body tube joint. Using your forefinger, smooth the glue into fillets. Since this is a scale model, it should not have fillets showing. Wipe any excess glue and allow to dry.

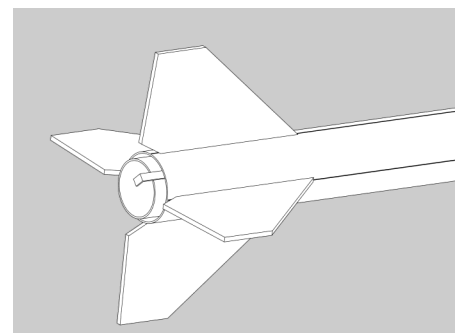

LAUNCH LUG

- ❑ 17. Glue the launch lug between two of the fins and about 1/2" from the bottom of the tube.

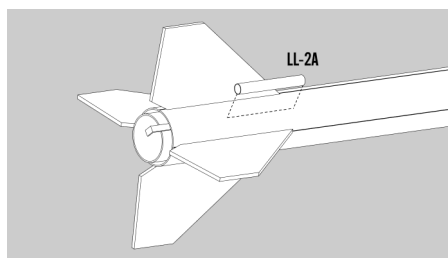

NOSE CONE

- ❑ 18. Insert the nose cone (BC-8460) in the top of the body tube and check for proper fit. The nose cone should be snug to hold itself in alignment. If it is too loose, add some masking tape. If it is too tight, sand the shoulder slightly.

- ❑ 19. Twist the screw eye (SE-12) into the center of the base of the nose cone. Remove it and squirt a drop of glue into the hole. Reinsert the screw eye and run a bead of glue around the shaft against the nose cone.

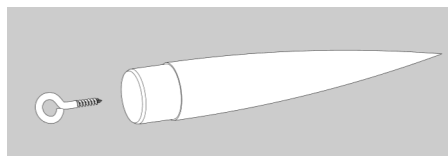

FINAL ASSEMBLY

- ❑ 20. Assemble the chute (CP-12BY) using the instructions that come with the Chute Pak. Pull the lines tight on the chute and make sure they are all of equal length. Attach the chute by tying them to the screw eye. Put a drop of glue on the joint to keep the lines from moving. Shake the elastic cord free and out of the top of the main tube. Attach the free end of the elastic cord to the screw eye. Put a drop of glue on that joint as well.

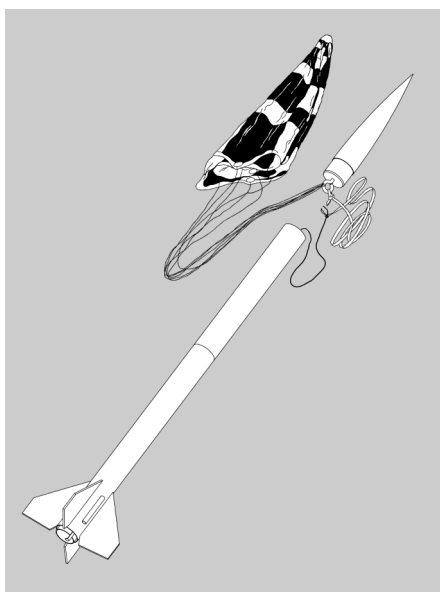

This completes the assembly of your
IQSY Tomahawk

FINISHING

- ❑ 21. For a smooth professional looking finish, fill the wood grain with balsa fillercoat or sanding sealer. When dry, sand with fine sandpaper. Repeat until smooth.

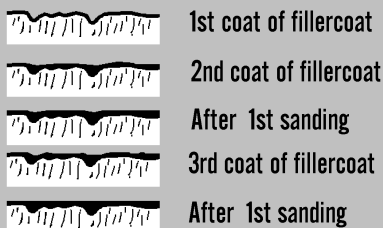

- ❑ 22. After all balsa surfaces have been prepared, wipe off all balsa dust with a dry cloth. First spray the model with an enamel primer. Choose a high visibility color like white for the final color. Refer to the front for suggested (scale) painting.

- ❑ 23. Spray painting your model with a fast-drying enamel will produce the best results. PATIENCE...is the most important ingredient. Use several thin coats, allowing each coat to completely dry before the next coat. Start each spray a few inches above the model and end a few inches below the model. Keep the can about 12" away and use quick light coats. The final coat can be a little heavier to give the model a glossy wet-looking finish.

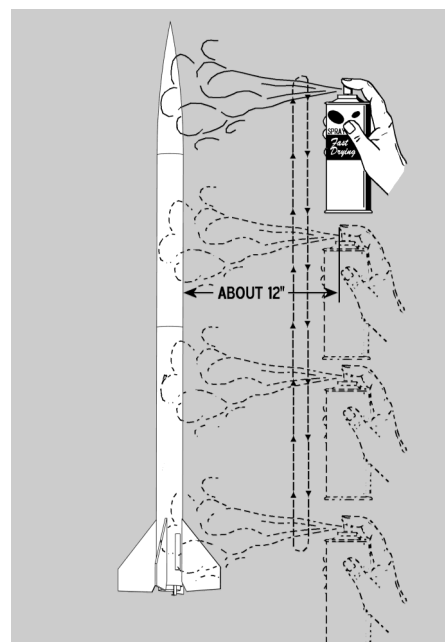

- ❑ 24. The only decal supplied with the IQSY Tomahawk is for non-scale use. The IQSY Tomahawk did not have lettering, but did have several gray bolts showing. Refer to the photo on the front for placement. If you do decide to use the included decal, cut it apart and dip it in a small dish of water that has a drop of detergent. It will take about 30 seconds before the decal is loose enough to apply. Slide it in place and use the paper backing to work the bubbles out.



FLIGHT PREPPING

25. Mounting the engine: Insert the engine and make sure the engine hook keeps the engine in snugly. The hook may be slightly bent to make sure the engine is retained.

26. Apply a few sheets of recovery wadding in the top of the body tube. Fold the parachute and pack it and the shock cord on top of the recovery wadding. Slide the nose cone into place, making sure it does not pinch the shock cord or parachute.

27. Refer to the model rocket engine manufacturer's instructions to complete the engine prepping. Different engines have different igniters and methods of hooking them up to the launch controllers.

28. Carefully check all parts of your rocket before each flight as a part of your pre-flight checklist. Launch the IQSY Tomahawk™ from a 1/8" diameter by 36" long launch rod.

29. After each flight, promptly remove the spent engine casing and dispose of properly.