



Model Rocket Safety Code

- 1. Materials.** I will use only lightweight, non-metal parts for the nose, body, and fins of my rocket.
- 2. Motors.** I will use only certified, commercially-made model rocket motors, and will not tamper with these motors or use them for any purposes except those recommended by the manufacturer.
- 3. Ignition System.** I will launch my rockets with an electrical launch system and electrical motor igniters. My launch system will have a safety interlock in series with the launch switch, and will use a launch switch that returns to the "off" position when released.
- 4. Misfires.** If my rocket does not launch when I press the button of my electrical launch system, I will remove the launcher's safety interlock or disconnect its battery, and will wait 60 seconds after the last launch attempt before allowing anyone to approach the rocket.
- 5. Launch Safety.** I will use a countdown before launch, and will ensure that everyone is paying attention and is a safe distance of at least 15 feet away when I launch rockets with D motors or smaller, and 30 feet when I launch larger rockets. If I am uncertain about the safety or stability of an untested rocket, I will check the stability before flight and will fly it only after warning spectators and clearing them away to a safe distance.
- 6. Launcher.** I will launch my rocket from a launch rod, tower, or rail that is pointed to within 30 degrees of the vertical to ensure that the rocket flies nearly straight up, and I will use a blast deflector to prevent the motor's exhaust from hitting the ground. To prevent accidental eye injury, I will place launchers so that the end of the launch rod is above eye level or will cap the end of the rod when it is not in use.
- 7. Size.** My model rocket will not weigh more than 1,500 grams (53 ounces) at liftoff and will not contain more than 125 grams (4.4 ounces) of propellant or 320 N-sec (71.9 pound-seconds) of total impulse. If my model rocket weighs more than one pound (453 grams) at liftoff or has more than four ounces (113 grams) of propellant, I will check and comply with Federal Aviation Administration regulations before flying.
- 8. Flight Safety.** I will not launch my rocket at targets, into clouds, or near airplanes, and will not put any flammable or explosive payload in my rocket.
- 9. Launch Site.** I will launch my rocket outdoors, in an open area at least as large as shown in the accompanying table, and in safe weather conditions with wind speeds no greater than 20 miles per hour. I will ensure that there is no dry grass close to the launch pad, and that the launch site does not present risk of grass fires.
- 10. Recovery System.** I will use a recovery system such as a streamer or parachute in my rocket so that it returns safely and undamaged and can be flown again, and I will use only flame-resistant or fireproof recovery system wadding in my rocket.
- 11. Recovery Safety.** I will not attempt to recover my rocket from power lines, tall trees, or other dangerous places.

LAUNCH SITE DIMENSIONS

Installed Total Impulse (N-sec)	Equivalent Motor Type	Minimum Site Dimensions (ft.)
0.00 — 1.25	1/4A	50
1.26 — 2.50	A	100
2.51 — 5.00	B	200
5.01 — 10.00	C	400
10.01 — 20.00	D	500
20.01 — 40.00	E	1000
40.01 — 80.00	F	1000
80.01 — 160.00	G	1000
160.01 — 320.00	2 Gs	1500

ARCON-HI™



1:6 SEMI-SCALE

FUN TO BUILD AND FLY

USES STANDARD ENGINES

TWO STAGE

CAN ALSO BE FLOWN AS SINGLE STAGE

BALSA FINS & NOSE CONE



FLYING MODEL ROCKET KIT



Made in the U.S.A by Semroc Astronautics Corporation - Knightdale, N.C. 27545

ARCON-HI™ Kit No. KV-15

Specifications	Engine	Approx. Altitude
Body Diameter	1.04" (2.6 cm)	B6-4 (Single Stage) 500'
Length	23.0" (58.42 cm)	C6-5 (Single Stage) 1100'
Fin Span	6.9" (17.5 cm)	B6-0, B6-6 900'
Net Weight	1.9 oz. (53.9 g)	C6-0, C6-7 1600'

PARACHUTE RECOVERY

What is a Retro-Repro™?

A Retro-Repro™ is a retro reproduction of an out-of-production model rocket kit. It is a close approximation of a full scale model of an early historically significant model rocket kit from one of the many companies that pioneered the hobby over the past half century. A Retro-Repro™ is not a true clone or identical copy of the original. It incorporates improvements using modern technology, while keeping the flavor and build appeal of the early kits.

About

Centuri Engineering Company

Centuri Engineering Company was started in 1961 by Leroy (Lee) Piester in his garage while he was still in college in Phoenix, Arizona. With his wife, Betty, they built Centuri into one of the largest model rocket companies ever.

Centuri was known for its unusual and innovative designs, producing over 140 different kits with something for every model rocketeer. They also produced model rocket engines and pioneered the modern composite high powered engines with their Enerjet line.

Centuri Engineering was sold to Damon in the late 1960's and shared the same parent corporation with Estes Industries, the largest model rocket company in the world. The Centuri product line was kept separate from the Estes line until 1983. A few of the old kits have been reissued by Estes since then, but for the most part, Centuri Engineering Company lives today only in the dreams of the senior members of the model rocket community.

March 11, 2008

Copyright © 2008 Semroc Astronautics Corporation
Box 1271 Knightdale, NC 27545 (919) 266-1977

LIMITATION OF LIABILITY

Model rockets are not toys, but are functional rockets made of lightweight materials and are launched with NAR or Tripoli safety certified model rocket motors, electrically ignited and flown in accordance with the NAR Model Rocket Safety Code. If misused, model rockets can cause serious injury and property damage. Semroc certifies that it has exercised reasonable diligence in the design and manufacture of its products. Semroc cannot assume any liability for the storage, transportation, or usage of its products. Semroc shall not be held responsible for any personal injury or property damage whatsoever arising out of the handling, storage, use, or misuse of our products. The buyer assumes all risks and liabilities therefrom and accepts and uses Semroc products on these conditions.

Your purchase and use of any Semroc products is construed as your agreement to and acceptance of these terms. If you do not agree to these terms and conditions, you must return the product, unused, for refund or credit.

100% SATISFACTION GUARANTEE

If you are not 100% satisfied with your Semroc product, we will make it right by providing whatever you consider fair, from refund to replacement.

Contact us at:

Semroc Astronautics Corporation

Customer Service Department
P.O. Box 1271
Knightdale, North Carolina 27545

JOIN THE NAR!

Sign up online at www.nar.org to join the premier model rocketry organization. Semroc fully supports the National Association of Rocketry and recognizes it as the sport's official voice. The NAR is the oldest and largest sport rocketry organization in the world. Since 1957 over 80,000 serious sport rocket modelers have joined the NAR to take advantage of the fun and excitement of organized rocketry. It is always more fun if you fly with friends. The *Sport Rocketry* magazine is one of the best ways to keep informed of new developments in the hobby. Check online at www.semroc.com/nar for promotions just for NAR members.



FLIGHT PREPPING

- ❑ **27.** Mounting the booster engine: Apply a piece of masking tape near the top of the booster engine and install it from the top of the booster. Engines used in the booster stage should always be booster engines with 0 seconds delay such as B6-0 or C6-0.

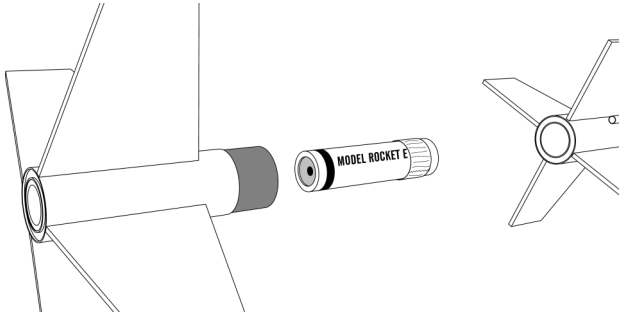

- ❑ **28.** Mounting the sustainer engine: Apply a piece of masking tape near the bottom of the sustainer engine and install it into the sustainer. Upper stage engines should be long delay. The upper stage may be flown as a single stage.

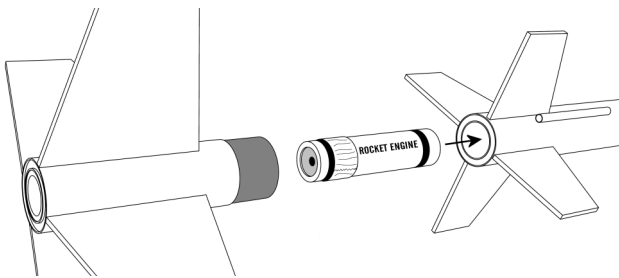

- ❑ **29.** Pack the recovery wadding from the top of the body tube. Use a sufficient quantity to protect the chute, but not too much that there is no room left for the parachute and lines.

- ❑ **30.** Roll the parachute and pack it and the shock cord on top of the recovery wadding. Slide the payload section into place, making sure it does not pinch the shock cord or chute.

- ❑ **31.** Refer to the model rocket engine manufacturer's instructions to complete the engine prepping. Different engines have different igniters and methods of hooking them up to the launch controllers.

- ❑ **32.** Carefully check all parts of your rocket before each flight as a part of your pre-flight checklist. Launch the Arcon-Hi™ from a 1/8" diameter by 36" long launch rod.

About the ARCON-HI™

The Centuri Arcon-Hi was released in the 1965 catalog. It was a semi-scale model of the Atlantic Research Corporation Arcon sounding rocket. Converted to a two-stage rocket, it used the dual-lock stage coupling that would later be patented. The booster was not scale, but the upper stage was a 1/6th scale model. The Centuri Arcon-Hi was catalog #KC-3 and was introduced with a price of \$2.85.

The Semroc Retro-Repro™ Arcon-Hi™ uses laser-cut balsa fins, balsa nose cone, balsa coupler, and parachute recovery. The dual-lock couplers are used to keep the model faithful to the original Centuri Arcon-Hi. Kevlar® thread and elastic cord provide an improved recovery system. A 12" two-color parachute is provided along with full-color water-slide decals.

BEFORE YOU START!

Make sure you have all the parts included in this kit that are listed in the Parts List in the center of these instructions. In addition to the parts included in this kit, you will also need the tools and materials listed below. Read the entire instructions before beginning to assemble your rocket. When you are thoroughly familiar with these instructions, begin construction. Read each step and study the accompanying drawings. Check off each step as it is completed. In each step, test-fit the parts together before applying any glue. It is sometimes necessary to sand lightly or build-up some parts to obtain a precision fit. If you are uncertain of the location of some parts, refer to the exploded view in the center of these instructions. It is important that you always ensure that you have adequate glue joints.

TOOLS: In addition to the parts supplied, you will need the following tools to assemble and finish this kit. Masking tape are also needed.



ASSEMBLY

1. These instructions are presented in a logical order to help you put your Arcon-Hi™ together quickly and efficiently. Check off each step as you complete it and we hope you enjoy putting this kit together.

PREPARE FINS

2. Lightly sand each side of each of the laser-cut fin sheets. Carefully push the laser-cut fins from their sheet. Start at one point on each fin and slowly and gently work around the fin.

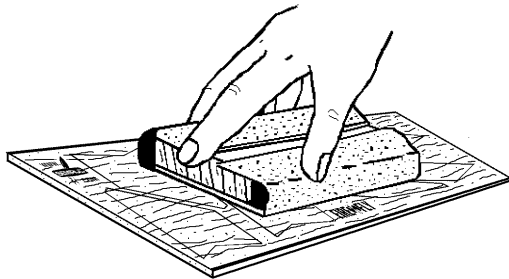

3. Stack all the fin pieces in groups of four fins each. Line each group up squarely and sand the fins back and forth over some fine sandpaper to get rid of the hold-in tabs as shown below.

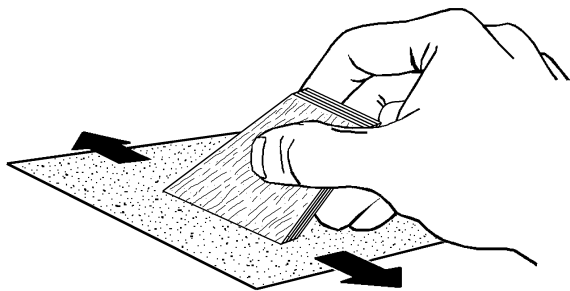

4. Repeat for all eight fins. The smaller fins are for the upper stage (sustainer) and the larger ones are for the lower stage (booster.) Round all the edges except the root edge.

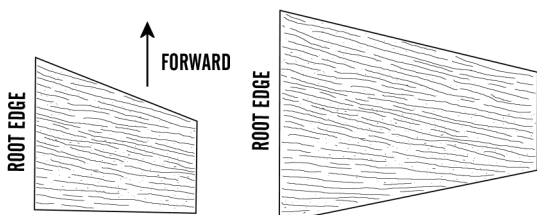

FINISHING

23. When the fillets have dried, prepare balsa surfaces for a smooth professional looking finish. Fill the wood grain with balsa fillercoat or sanding sealer, When dry, sand with fine sandpaper. Repeat until smooth.

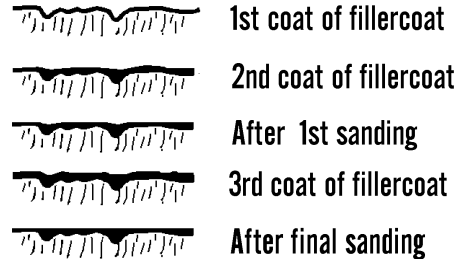

24. After all balsa surfaces have been prepared, wipe off all balsa dust with a dry cloth. First spray the model with an enamel primer. Choose a high visibility color combination like white, black, and yellow for the final color.

25. Spray painting your model with a fast-drying enamel will produce the best results. PATIENCE...is the most important ingredient. Use several thin coats, allowing each coat to completely dry before the next coat. Start each spray a few inches above the model and end a few inches below the model. Keep the can about 12" away and use quick light coats. The final coat can be a little heavier to give the model a glossy wet-looking finish.

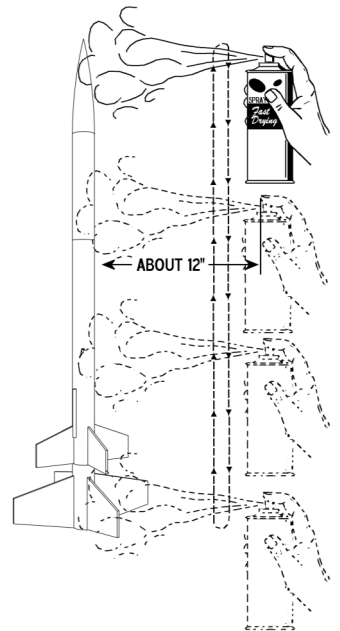

26. After the paint has dried, decals should be applied. The decals supplied with the Arcon-Hi™ are waterslide decals. Each decal should be cut separately from the sheet. Apply each decal before starting the next. Think about where you want to apply each decal and check for fit before wetting the decal. Use the cover photo as a guide for applying decals.

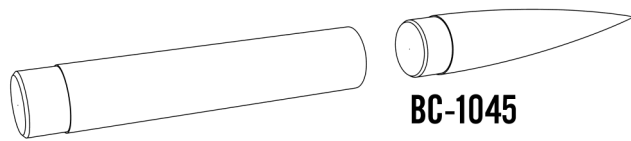

❑ **21.** Turn the screw eye (SE-12) into the center of the base of the nose block. Unscrew it and squirt glue into the hole. Reinstall the screw eye and wipe off any excess glue.

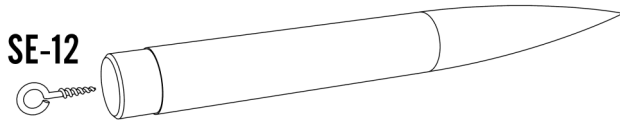

FINAL ASSEMBLY

❑ **22.** Pull the Kevlar® cord out through the top of the sustainer tube. Tie it to one end of the elastic cord with an overhand knot. Tie the free end of the elastic cord to the screw eye. Assemble the chute using the instructions printed on the canopy and attach to the screw eye as shown.

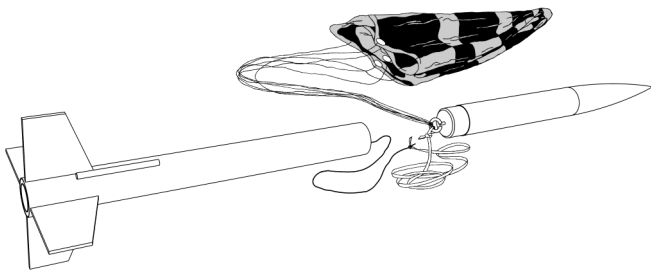

This completes the assembly of your

ARCON-HI

BOOSTER ASSEMBLY

❑ **5.** Insert the engine spacing tube (MC-727) in one end of one of the engine tubes (ST-730) and a thrust block in the opposite end. Make sure the end of the spacing tube is even with the end of the engine tube. The thrust block will be slightly recessed.

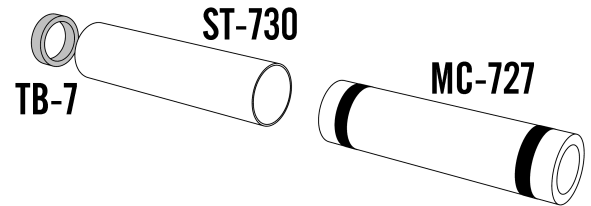

❑ **6.** Apply a heavy fillet of glue around the recessed thrust block, securing it to the engine tube. Remove the engine spacing tube without disturbing the thrust block. Allow to dry. Repeat with the other engine tube and thrust block for the sustainer and set it aside also.

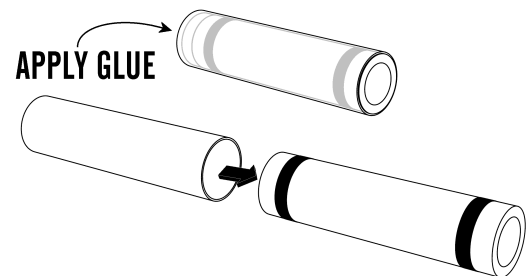

❑ **7.** Glue one centering ring (CR-710) flush with the end of the engine tube that has the thrust block. Glue another centering ring (CR-710) on the opposite end leaving 1/2" of the engine tube exposed. Apply a fillet of glue around the centering rings.

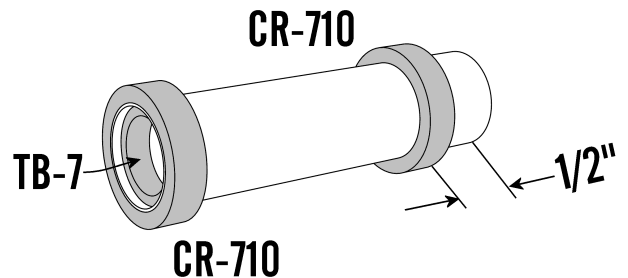

❑ **8.** Check the HTC-7B for fit on the engine tube. It should be snug. Glue it on the engine tube leaving 1/4" of the engine tube exposed.

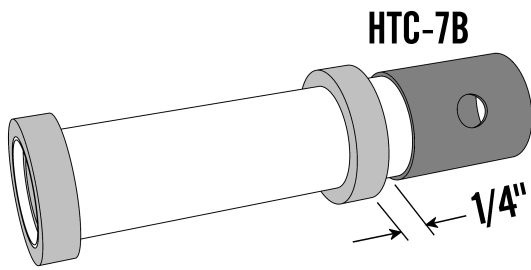

- 9. Apply a generous amount of glue around the inside facing edges of the centering rings and slide this assembly into the booster body tube (ST-1030). Make sure the bottom ends are flush. Roll the assembly to allow the glue to flow around the centering rings. Apply a bead of glue around the flush end. Allow all glue to dry.

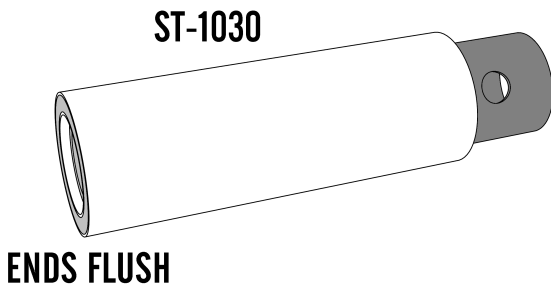

- 10. Apply a bead of glue around the inside of the engine body tube near the coupler. Insert the tube coupler (HTC-10) inside the body tube until it is in place against the top centering ring. The booster engine mount is completed. Set it aside to dry with the couplers pointed up.

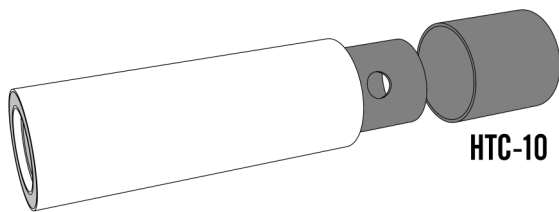

SUSTAINER ASSEMBLY

- 11. Tie a large knot in one end of the Kevlar thread. Feed it through a centering ring (CR-710) and glue the ring on the engine tube assembly even with the same end with the thrust block. Glue the remaining centering ring 1" from the opposite end of the engine tube. Apply generous fillets around each ring. Make sure the Kevlar knot is secure.

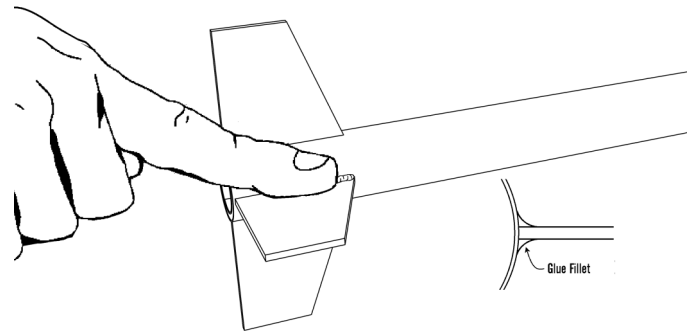

LAUNCH LUG

- 18. Glue the launch lug (LL-122) to the sustainer body tube as shown. Note that it is not centered between the fins, but slightly off center.

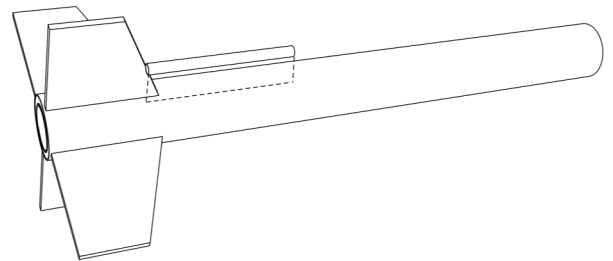

PAYLOAD SECTION

- 19. Mark the balsa tube coupler (BTC-10) 3/4" from one end. Apply a bead of glue inside the payload tube (ST-1050) and insert the balsa coupler until the mark is even with the end of the tube. Wipe any excess glue.

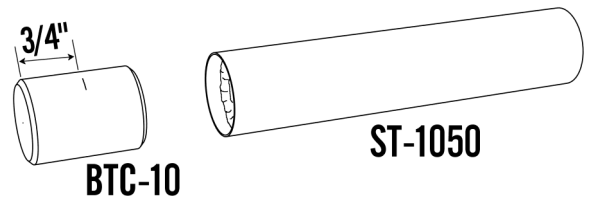

- 20. Insert the nose cone in the body tube and check for proper fit. The nose cone should be snug to hold itself in alignment. If it is too loose, add masking tape. If it is too tight, sand the shoulder slightly. Do not glue the nose cone so you can access the payload area.

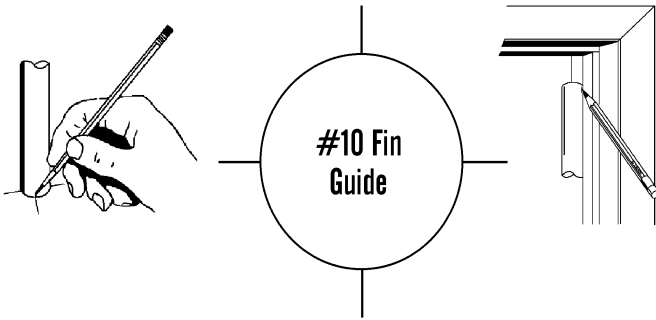

❑ **15.** Apply glue to the root edge of a booster fin and position it along one of the lines drawn on the side of the booster body tube. Remove, allow to dry, apply additional glue, and reposition. Repeat for the other three fins.

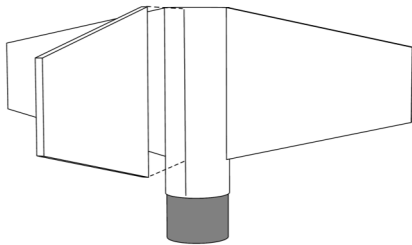

❑ **16.** Apply glue to the root edge of a sustainer fin and position it along one of the lines drawn on the side of the sustainer body tube. Remove, allow to dry, apply additional glue, and reposition. Repeat for the other three fins.

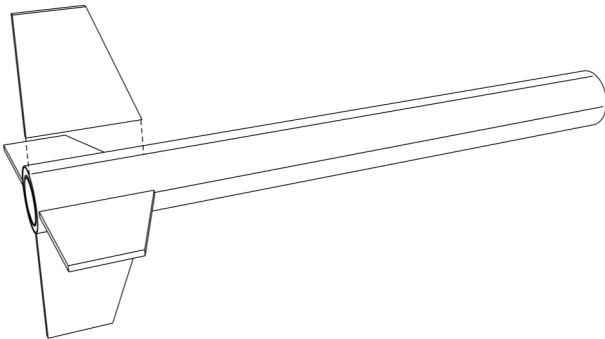

❑ **17.** After both fin assemblies are completely dry, run a small bead of glue along both sides of each fin-body tube joint. Using your forefinger, smooth the glue into fillets.

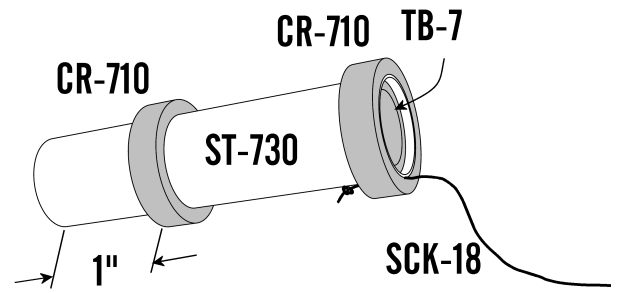

❑ **12.** Pull the Kevlar thread back through the engine mount to keep it out of the way. Apply a bead of glue inside the sustainer body tube (ST-10105) as shown. Apply a bead of glue around the front edge of both rings as well.

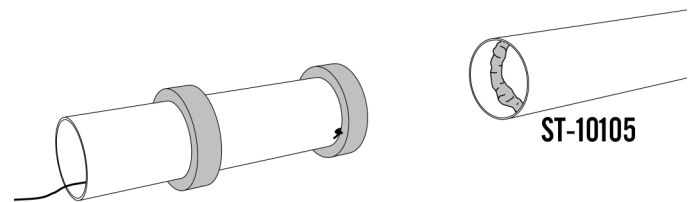

❑ **13.** Insert the engine mount in the sustainer body tube until the ends are flush. Rotate the assembly until the glue has flowed around the rings uniformly. Set it on the end until it is completely dry.

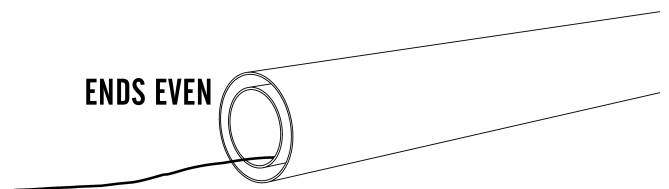

FIN ASSEMBLY

❑ **14.** Stand the booster assembly (coupler end up) on the fin guide on page 10 and make the fin position marks on the side of the tube. Find a convenient channel or groove such as a partially open drawer, a door jamb (as shown,) or a piece of molding. Using the channel, extend the marks the full length of the tube to provide lines for aligning the fins. Repeat for the sustainer tube.

Parts List

Exploded View

- A) 1 Balsa Nose ConeBC-1045
- B) 1 Balsa Tube Coupler.....BTC-10
- C) 1 Body TubeST-10105
- D) 1 Body TubeST-1030
- E) 1 Body TubeST-1050
- F) 2 Body TubesST-730
- G) 1 Laser Cut Fin SetFV-15
- H) 1 Tubing CouplerHTC-10
- I) 1 Tubing CouplerHTC-7B
- J) 4 Centering RingsCR-710
- K) 2 Thrust Blocks.....TB-7
- L) 1 Launch Lug.....LL-122
- M) 1 Screw Eye.....SE-12
- N) 1 Elastic Cord.....EC-118
- O) 1 Kevlar Thread.....SCK-18
- P) 1 Plastic Parachute.....RC-12
- Q) 1 Tape Discs.....TD-6
- R) 1 Shroud LineSLT-6
- S) 1 Empty Casing.....MC-727
- T) 1 DecalDKV-15

