



# Model Rocket Safety Code

- 1. Materials.** I will use only lightweight, non-metal parts for the nose, body, and fins of my rocket.
- 2. Motors.** I will use only certified, commercially-made model rocket motors, and will not tamper with these motors or use them for any purposes except those recommended by the manufacturer.
- 3. Ignition System.** I will launch my rockets with an electrical launch system and electrical motor igniters. My launch system will have a safety interlock in series with the launch switch, and will use a launch switch that returns to the "off" position when released.
- 4. Misfires.** If my rocket does not launch when I press the button of my electrical launch system, I will remove the launcher's safety interlock or disconnect its battery, and will wait 60 seconds after the last launch attempt before allowing anyone to approach the rocket.
- 5. Launch Safety.** I will use a countdown before launch, and will ensure that everyone is paying attention and is a safe distance of at least 15 feet away when I launch rockets with D motors or smaller, and 30 feet when I launch larger rockets. If I am uncertain about the safety or stability of an untested rocket, I will check the stability before flight and will fly it only after warning spectators and clearing them away to a safe distance.
- 6. Launcher.** I will launch my rocket from a launch rod, tower, or rail that is pointed to within 30 degrees of the vertical to ensure that the rocket flies nearly straight up, and I will use a blast deflector to prevent the motor's exhaust from hitting the ground. To prevent accidental eye injury, I will place launchers so that the end of the launch rod is above eye level or will cap the end of the rod when it is not in use.
- 7. Size.** My model rocket will not weigh more than 1,500 grams (53 ounces) at liftoff and will not contain more than 125 grams (4.4 ounces) of propellant or 320 N-sec (71.9 pound-seconds) of total impulse. If my model rocket weighs more than one pound (453 grams) at liftoff or has more than four ounces (113 grams) of propellant, I will check and comply with Federal Aviation Administration regulations before flying.
- 8. Flight Safety.** I will not launch my rocket at targets, into clouds, or near airplanes, and will not put any flammable or explosive payload in my rocket.
- 9. Launch Site.** I will launch my rocket outdoors, in an open area at least as large as shown in the accompanying table, and in safe weather conditions with wind speeds no greater than 20 miles per hour. I will ensure that there is no dry grass close to the launch pad, and that the launch site does not present risk of grass fires.
- 10. Recovery System.** I will use a recovery system such as a streamer or parachute in my rocket so that it returns safely and undamaged and can be flown again, and I will use only flame-resistant or fireproof recovery system wadding in my rocket.
- 11. Recovery Safety.** I will not attempt to recover my rocket from power lines, tall trees, or other dangerous places.

## LAUNCH SITE DIMENSIONS

Installed Total Impulse (N-sec)	Equivalent Motor Type	Minimum Site Dimensions (ft.)
0.00 — 1.25	1/4A	50
1.26 — 2.50	A	100
2.51 — 5.00	B	200
5.01 — 10.00	C	400
10.01 — 20.00	D	500
20.01 — 40.00	E	1000
40.01 — 80.00	F	1000
80.01 — 160.00	G	1000
160.01 — 320.00	2 Gs	1500

# the amazing POINT



**UNUSUAL RIGID CHUTE RECOVERY!**

**EASY TO BUILD**

**PRE-PRINTED SHROUD**

**BALSA NOSE CONE**

**LASER-CUT BALSA FINS**

FLYING MODEL ROCKET KIT

**SEMROC**

Made in the U.S.A by Semroc Astronautics Corporation - Knightdale, N.C. 27545

## POINT Kit No. KV-58

Specifications	Engine	Approx. Altitude
Body Diameter .759" (1.9cm)	B4-2	250'
Length 8.6" (21.8cm)	B6-2	225'
Base Diameter 3.9" (9.9cm)	C6-3	450'
Net Weight .5 oz. (14.1g)		

**RIGID CHUTE RECOVERY**

## What is a Retro-Repro?

A retro-repro is a retro reproduction of an out-of-production model rocket kit. It is a close approximation of a full scale model of an early historically significant model rocket kit from one of the many companies that pioneered the hobby over the past half century. A retro-repro is not a true clone or identical copy of the original. It incorporates improvements using modern technology, while keeping the flavor and build appeal of the early kits.

---

## About Centuri Engineering Company

Centuri Engineering Company was started in 1961 by Leroy (Lee) Piester in his garage while he was still in college in Phoenix, Arizona. With his wife, Betty, they built Centuri into one of the largest model rocket companies ever.

Centuri was known for its unusual and innovative designs, producing over 140 different kits with something for every model rocketeer. They also produced model rocket engines and pioneered the modern composite high powered engines with their Enerjet line.

Centuri Engineering was sold to Damon in the late 1960's and shared the same parent corporation with Estes Industries, the largest model rocket company in the world. The Centuri product line was kept separate from the Estes line until 1983. A few of the old kits have been reissued by Estes since then, but for the most part, Centuri Engineering Company lives today only in the dreams of the senior members of the model rocket community.

---

July 22, 2006

Copyright © 2006 Semroc Astronautics Corporation  
Box 1271 Knightdale, NC 27545 (919) 266-1977

## LIMITATION OF LIABILITY

Model rockets are not toys, but are functional rockets made of lightweight materials and are launched with NAR or Tripoli safety certified model rocket motors, electrically ignited and flown in accordance with the NAR Model Rocket Safety Code. If misused, model rockets can cause serious injury and property damage. Semroc certifies that it has exercised reasonable diligence in the design and manufacture of its products. Semroc cannot assume any liability for the storage, transportation, or usage of its products. Semroc shall not be held responsible for any personal injury or property damage whatsoever arising out of the handling, storage, use, or misuse of our products. The buyer assumes all risks and liabilities therefrom and accepts and uses Semroc products on these conditions.

Your purchase and use of any Semroc products is construed as your agreement to and acceptance of these terms. If you do not agree to these terms and conditions, you must return the product, unused, for refund or credit.

## 100% SATISFACTION GUARANTEE

If you are not 100% satisfied with your Semroc product, we will make it right by providing whatever you consider fair, from refund to replacement.

Contact us at:

**Semroc Astronautics Corporation**

Customer Service Department  
P.O. Box 1271  
Knightdale, North Carolina 27545

## JOIN THE NAR!

Sign up online at [www.nar.org](http://www.nar.org) to join the premier model rocketry organization. Semroc fully supports the National Association of Rocketry and recognizes it as the sport's official voice. The NAR is the oldest and largest sport rocketry organization in the world. Since 1957 over 80,000 serious sport rocket modelers have joined the NAR to take advantage of the fun and excitement of organized rocketry. It is always more fun if you fly with friends. The *Sport Rocketry* magazine is one of the best ways to keep informed of new developments in the hobby. Check online at [www.semroc.com/nar](http://www.semroc.com/nar) for promotions just for NAR members.



- 24.** Refer to the model rocket engine manufacturer's instructions to complete the engine prepping. Different engines have different igniters and methods of hooking them up to the launch controllers. Since the engine is so far up into the Point, it is recommended that you add short lengths of insulated wire to the igniter to lengthen the leads. If you use the wire, it should be at least 3" long. If you reuse the wire on another flight, make sure the insulation is not burned or it could cause a short.

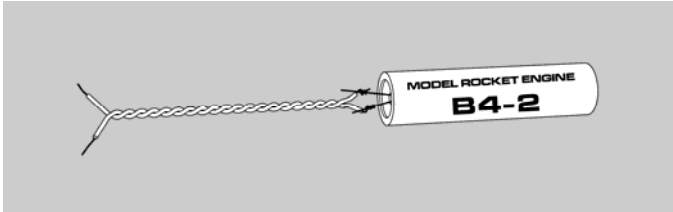

- 25.** Slide the ring attached to the elastic cord over the bottom of the engine, leaving about 1/2" of space from the nozzle end. Add a small amount of masking tape to make sure it remains attached during flight. To keep the elastic cord out of the way of the exhaust, it can be taped to the side of the shroud with a small piece of masking tape. Desensitize the tape by sticking it to your forehead first to take some of the stickiness out of it so it will come loose in flight without taking the shroud with it!

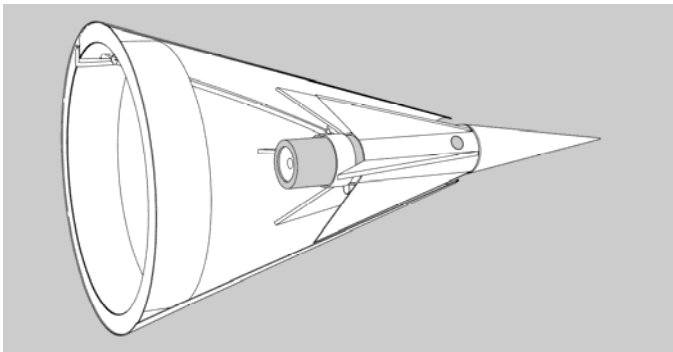

- 26.** Using a 1/8" by 36" launch rod, wrap several layers of masking tape on the launch rod about 10-12" from the blast deflector. This will keep your Point high on the rod away from the blast-back from the deflector when the engine ignites. The biggest danger to your Point is the hot gases igniting the shroud and base ring.

- 27.** Since the stability is so close on your Point, it is best to launch in calm wind conditions and always in a vertical direction.

- 28.** After each flight, remove the spent engine casing and clean the model thoroughly for many hours of fun flying with your amazing Point!

## About the amazing Point™

The Centuri Point was initially released in 1969. It was designed to show that a model rocket did not have to look like a rocket to fly. Basically a cone shape, it taught some principles of stability. It also showed that the rocket could be used as its own "chute." The Point did not stay on the market long, disappearing from the 1972 catalog, but its look and appeal was definitely vintage Centuri. The Centuri Point was introduced as catalog #KC-13 and had an initial price of \$1.50.

The Semroc Point™ is a faithful recreation of the original. It uses a precision shaped balsa nose cone. Laser-cut balsa fins are included instead of the original blank sheet with a fin pattern sheet. The canopy was changed to self-adhesive from the original water-based glue. A high gloss full color shroud is provided so there is very little left to paint. An elastic cord is provided instead of the original rubber shock cord.

### BEFORE YOU START!

Make sure you have all the parts included in this kit that are listed in the Parts List in the center of these instructions. In addition to the parts included in this kit, you will also need the tools and materials listed below. Read the entire instructions before beginning to assemble your rocket. When you are thoroughly familiar with these instructions, begin construction. Read each step and study the accompanying drawings. Check off each step as it is completed. In each step, test-fit the parts together before applying any glue. It is sometimes necessary to sand lightly or build-up some parts to obtain a precision fit. If you are uncertain of the location of some parts, refer to the exploded view in the center of these instructions. It is important that you always ensure that you have adequate glue joints.

**TOOLS:** In addition to the parts supplied, you will need the following tools to assemble and finish this kit. Wax paper, masking tape, and Scotch® tape are also required.



## ASSEMBLY

- ❑ **1.** These instructions are presented in a logical order to help you put your Point™ together quickly and efficiently. Check off each step as you complete it and enjoy putting this kit together.

## PREPARE FINS

- ❑ **2.** Lightly sand each side of the laser-cut balsa fin sheet.

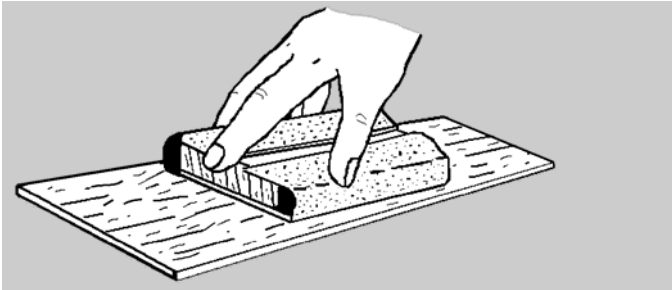

- ❑ **3.** Carefully remove the laser-cut fins from the balsa fin sheet. Stack all six fins together and sand off the holding tabs as shown in the illustration below.

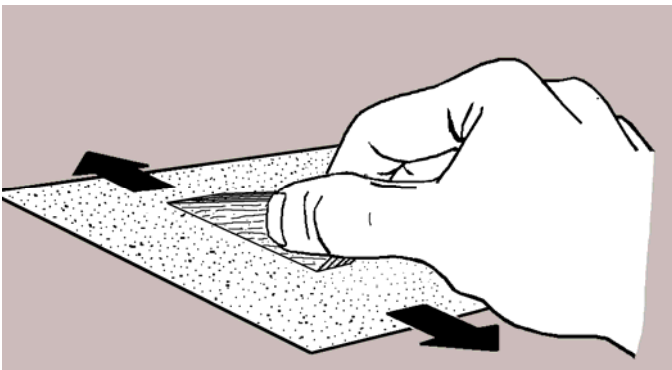

## APPLY FINS

- ❑ **4.** Using the fin marking guide mark the locations of the fins. Align the holes as shown. Using a drawer, angle strip, or door jam to extend all six lines for the length of the tube.

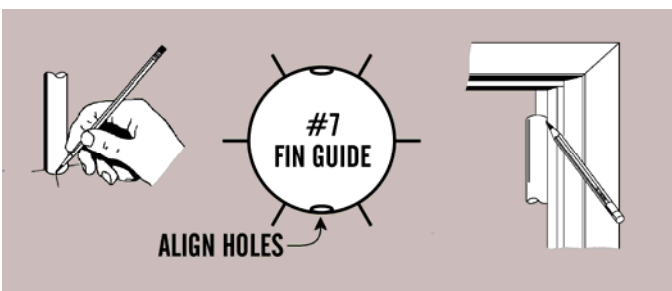

- ❑ **22.** Tie one end of the elastic cord to the small engine ring. Insert the other end into the notch on the base disc and out through the square hole in the red ring. There should be just enough left to allow the ring to touch the bottom of the main body tube. When you have the correct length, tie a knot in the bottom end. Squirt a bead of glue into both holes to secure the bottom of the shock cord and strengthen the joint.

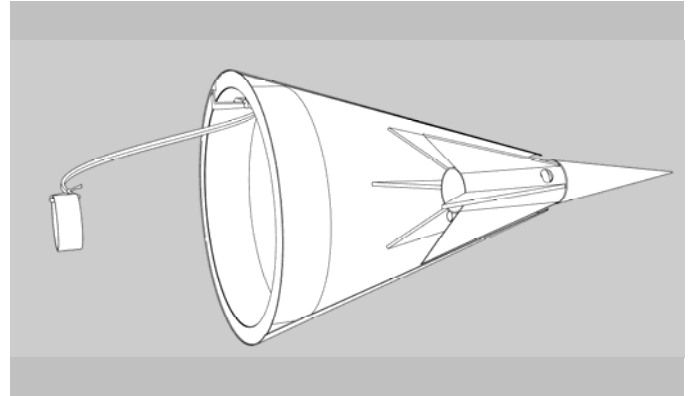

*This completes the  
assembly of*

*the amazing*  
**POINT**

## FLIGHT PREPPING

- ❑ **23.** Choose an engine for your flight. It is recommended that you use a **B4-2** for your first flight. It is a gentler flight than the other choices. A **B6-2** can also be used as a second choice. A **C6-3** can be used, but it has a long delay for the Point so it will eject on the way down. If you use a C6-3, make sure your recovery area is soft. **Don't fly a C6-3 on your first flight in case it is not stable.** Apply a small amount of masking tape around the top of the engine. Test fit it in the body tube. It should be just tight enough to stay in when you lightly shake the rocket.

# FINAL ASSEMBLY

- ❑ **19.** Refer to this top view when attaching the nose cone and cockpit in the following steps.

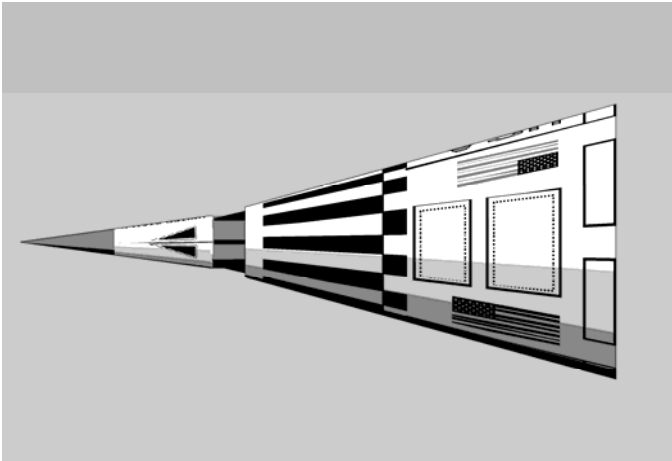

- ❑ **20.** Apply a bead of glue on each fin edge. Fit the cockpit assembly into the cone assembly. Turn it so the holes are at the sides. The large hatches are on the top centerline. Grip the nose cone and position the assembly. Hold in place until the glue sets.

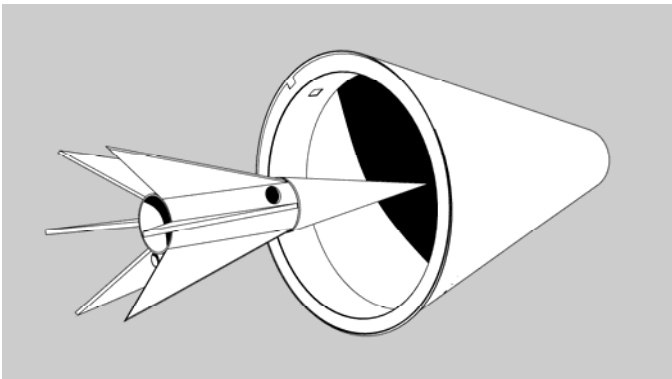

- ❑ **21.** When all the glue has dried, cut out the cockpit from the pressure sensitive sheet. The mid line between the two windows should be aligned with the top fin edge that is in line with the large hatches. Start by lining it up against the shoulder of the nose cone and in the middle of the cone. Slowly press the label down, making sure it follows the contour of the nose cone.

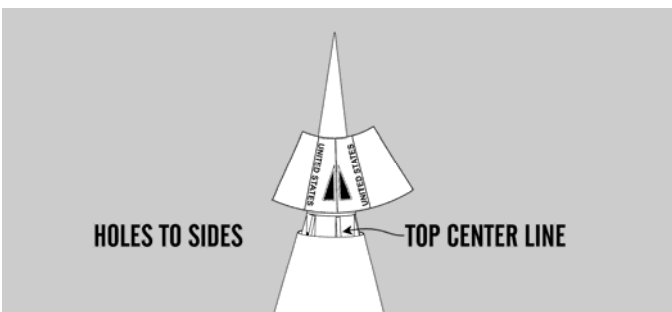

- ❑ **5.** Apply a thin film of glue to all six fins along the root edge (the second shortest edge.) Touch it lightly to one of the lines marked on the body tube. Sit it aside and repeat for the remaining five fins. When the glue is almost dry, apply another thin bead on the first fin and attach it to the body tube with the hole as shown. Hold for a few seconds until it sets. Repeat for the remaining five fins. Check that they are all even and perpendicular to the body tube as shown in the end view. A coat of glue will help flameproof the base of the fins.

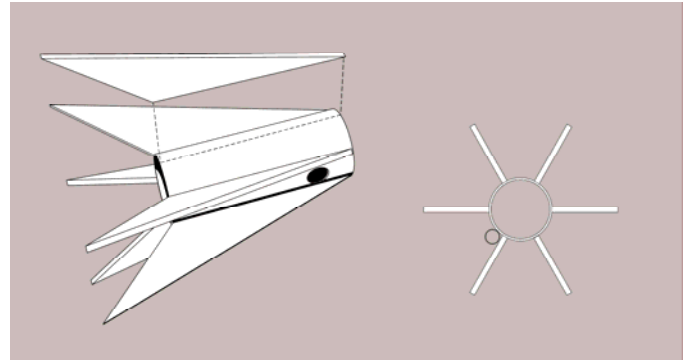

# NOSE CONE

- ❑ **6.** Check the nose cone for fit. Sand the shoulder lightly if it is too tight. Apply a bead of glue just inside the top of the body tube and insert the nose cone. Make sure the glue does not cover the holes. Also make sure there is no glue inside that will prevent the engine from seating against the nose cone.

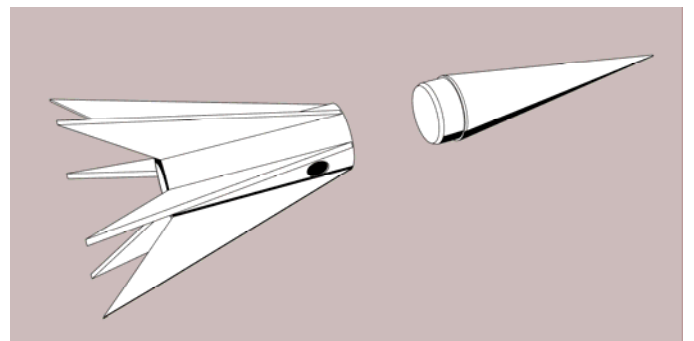

# LAUNCH LUG

- ❑ **7.** Apply a bead of glue along one of the fin and body tube joints. Apply the launch lug against the fin and even with the bottom of the body tube. Apply a fillet of glue along each joint and sit this assembly aside to dry.



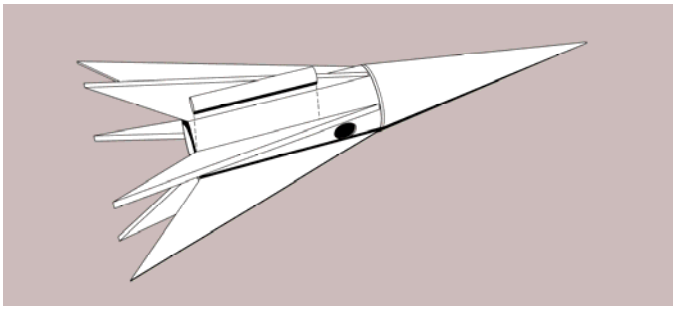

## PAINT COCKPIT

- ❑ **8.** When the cockpit assembly is dry, spray with white paint. Allow the paint to dry and mask off the bottom section leaving about 1-1/4" of the tip of the nose cone exposed. Spray the tip red. Allow the paint to dry, then remove the masking tape.

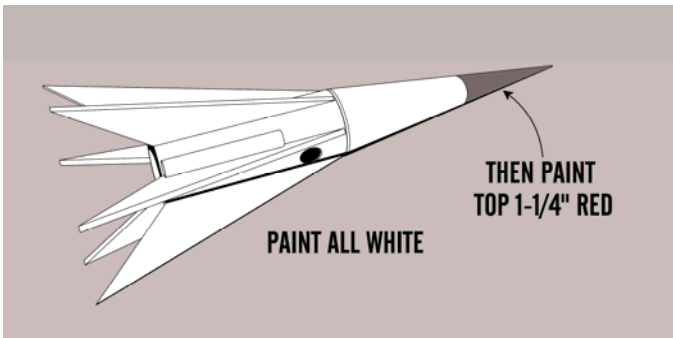

## CONE BODY

- ❑ **9.** Since the cone body is printed on a high gloss paper and will be the final finish, make sure your work area and hands are clean before proceeding. Keep glue to a minimum because any runs, drips, or smudges will show on the final model. Cut out the main body with a sharp pair of scissors. Form it into a cone by rolling it carefully until it will stand by itself as shown. Then apply a strip of Scotch® tape along the inside of the seam with the dotted line.

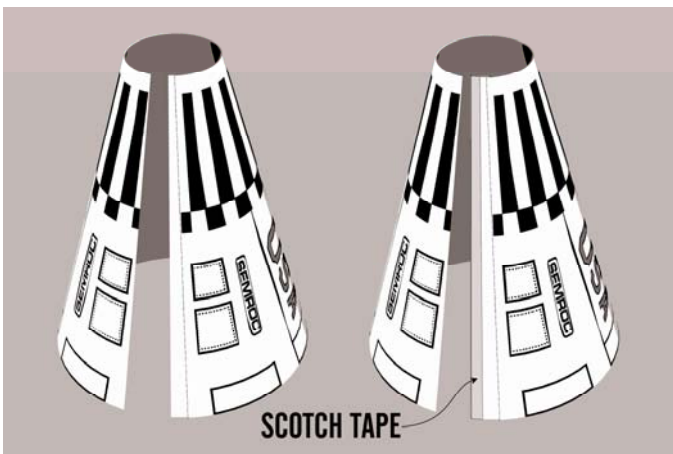

- ❑ **16.** When the base is completely dry, cut away the excess overhang from the bottom (red) ring so it is even with the small ring. Cut a small notch from the two combined rings in line with the square hole in the cylinder. This will form the shock cord attachment point later.

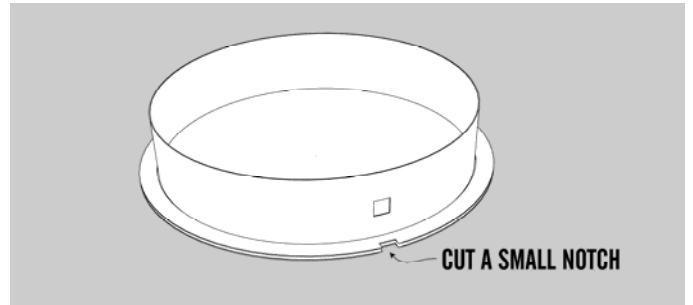

- ❑ **17.** Check for fit of the base into the bottom of the cone. Sand lightly to achieve proper fit. Run a bead of glue around the inside of the bottom edge of the cone. Place it immediately over the base assembly. The bead of glue will run down forming an inside fillet against the base assembly. Wait for this assembly to dry completely.

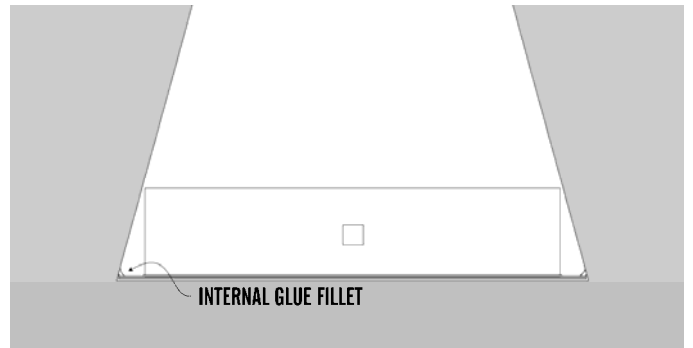

- ❑ **18.** Cut a hole in the bottom of the red ring. Be careful not to cut too much away now. Cut a large enough hole to be able to glue inside the cone. Run a thin bead of glue around the joint the cylinder makes with the cone and use your finger to smooth the fillet. When it is completely dry, finish trimming the base ring with a sharp hobby knife so it is even with the red cylinder.

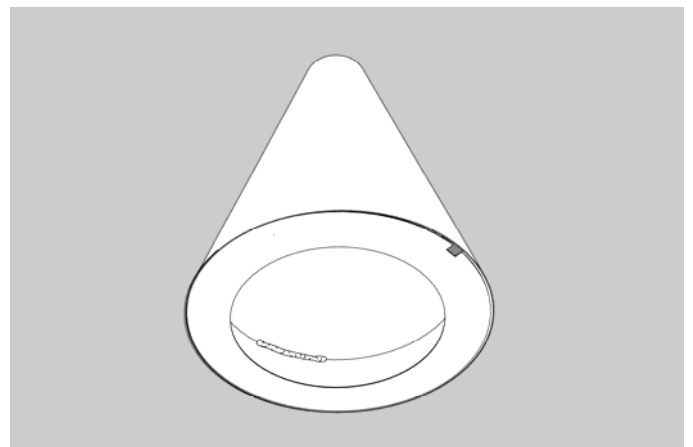

**13.** Cut out the long red strip with scissors. Using a hobby knife, carefully cut out the two small square holes. Apply glue at one end inside the dotted line area and wrap it into a cylinder with the two square holes aligned and the red side to the inside of the cylinder. Hold until it sets then allow it to dry.

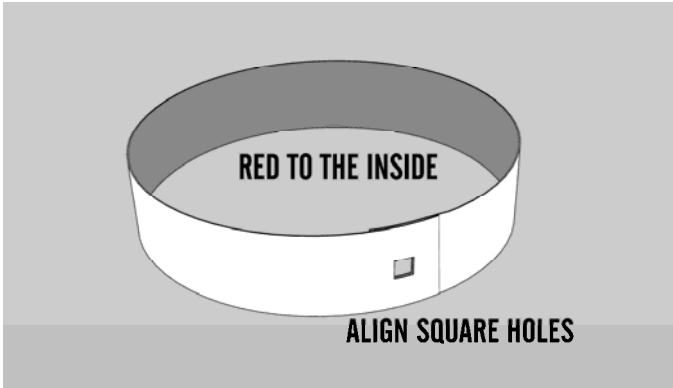

**14.** Run a bead of glue around the inside edge of the small ring. Allow it to get tacky, but not too dry. This will help hold the cylinder in place in the next step.

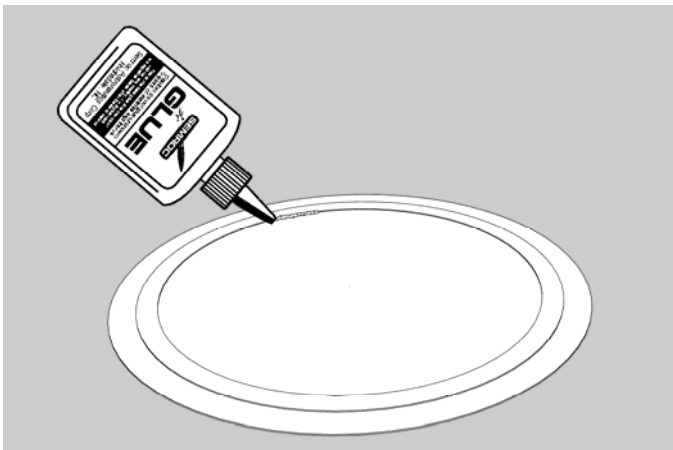

**15.** Line up the red strip so it fits inside the small ring. Once you have it tacked down and you are sure it is in position, place a light book on the top of the cylinder.

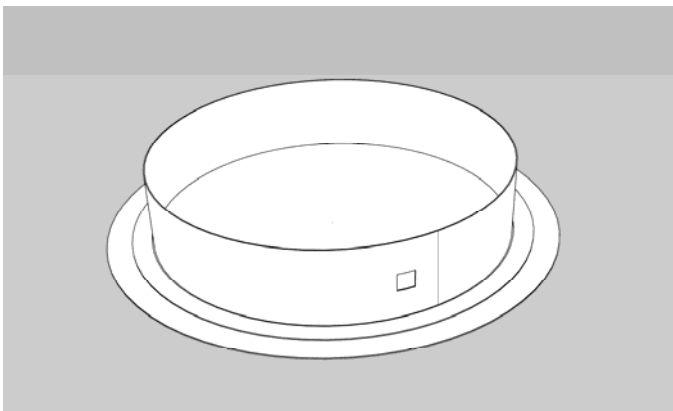

**10.** For best results, fold the Scotch tape back toward the inside of the shroud. Align the outside edge along the dotted line. When the edges are positioned correctly, press the tape down at the top of the shroud, then at the bottom. When the shroud is correct, press the entire length of tape in place.

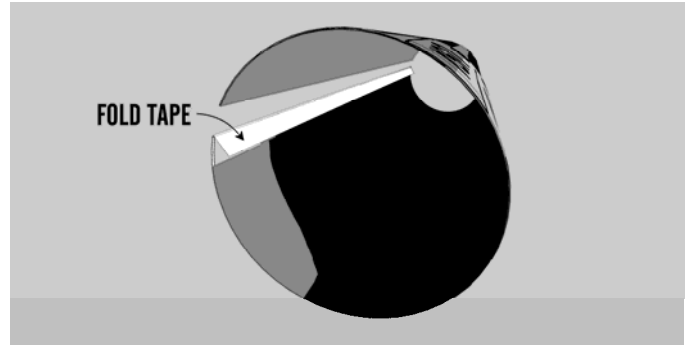

**11.** Squeeze the cone slightly to expose the glue tab. Apply a thin bead of glue along the surface. Smooth it with your finger so it is a very thin, uniform film. Allow to dry for a few moments. Press the joint against a wax paper covered flat surface and allow to dry for about a minute. Set the cone on its base and allow to dry completely.

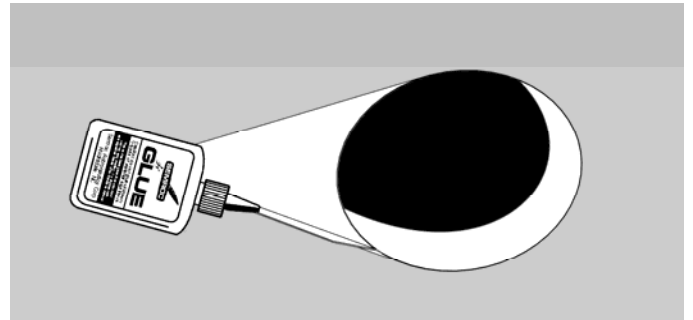

## CONE BASE

**12.** Cut out both paper rings from the pre-printed sheet. Leave the inside ring of the larger red disc uncut for now. Glue the small ring on the back of the red ring centered as close as you can get it. Press it down firmly and allow to dry completely. Placing it between wax paper sheets and pressing it with a book or other flat object will keep it from bowing while it dries.

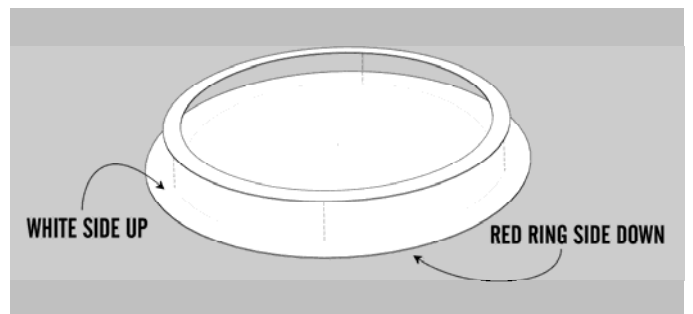

## Parts List

- A 1 Body Tube with holes ..... ST-720H
- B 1 Balsa Nose Cone ..... BC-728
- C 1 Laser Cut Fin Set ..... FV-58
- D 1 Point Shroud ..... IKV-58S
- E 1 Point Base ..... IKV-58B
- F 1 Engine Ring ..... ST-703
- G 1 Launch Lug ..... LL-2A
- H 1 Elastic Cord ..... EC-109
- I 1 Cockpit Wrap ..... IKV-58C

# EXPLODED VIEW

