

About Estes Industries, Inc.

In July 1958, G. Harry Stine of Model Missiles, Inc. in Denver, Colorado approached Vern Estes about making model rocket engines for them. On January 15, 1959, Vern's automated model rocket engine fabricating machine, "Mabel", produced the first of many millions of Estes model rocket engines. In 1960, Estes was producing more engines than Model Missiles could sell. Vern and his wife Gleda opened a mail order rocket company and introduced the Astron Scout and Astron Mark.

In 1961, a catalog was mimeographed and hand stitched on Gleda's sewing machine. Later that year, Estes Industries had outgrown the confined space in Denver. In December 1961, the entire operation was moved to an old farm in Penrose, Colorado quickly establishing the small town as the "Model Rocket Capital of the World."

Estes Industries was sold to Damon in September 1969. The name Estes is synonymous with model rocketry. Almost everyone remembers growing up firing Estes rockets or knowing someone that did. Estes Industries has introduced millions of youngsters of all ages to model rocketry for almost half a century.

About the Starship Excalibur™

The original Starship Excalibur was released by Estes Industries in 1968 as free plan #55. Unlike many of the other free plans at the time, it was not published in the Model Rocket News. It became a popular model as many rocketeers ordered parts to build their own version. Estes released a kit by the same name and similar lines in 1984, but it was a simplified version of the original and only had a two-year run in production.

The Semroc Retro-Repro™ Starship Excalibur™ is close to the original plan design. Seven balsa nose cones and laser cut fins along with pre-cut slots make this an easy-to-build model. It features a large waterslide decal to match the original plan drawing. The shock mount is replaced with a Kevlar® cord for greater reliability.

What is a Retro-Repro?

A Retro-Repro™ is a retro reproduction of an out-of-production model rocket kit. It is a close approximation of a full scale model of an early historically significant model rocket kit from one of the many companies that pioneered the hobby over the past half century. A Retro-Repro™ is not a true clone or identical copy of the original. It incorporates improvements using modern technology, while keeping the flavor and build appeal of the early kits.

April 1, 2013

Copyright © 2013 Semroc Astronautics Corporation
Box 1271 Knightdale, NC 27545 (919) 266-1977

Starship Excalibur™

CLASSIC DESIGN

STARSHIP SERIES

EASY TO BUILD

BALSA FINS & NOSE CONES

FLYING MODEL ROCKET KIT

1968 Retro-Repro

LASER CUT FINS

MADE IN THE USA

SEMROC

Made in the U.S.A by Semroc Astronautics Corporation - Knightdale, N.C. 27545

Starship Excalibur™ Kit No. KV-85

Specifications	Engine	Approx. Altitude
Body Diameter 1.325" (3.4 cm)	A8-3	100'
Length 20.5" (52.1 cm)	B6-4	300'
Fin Span 8.9" (22.6 cm)	C6-5	750'
Net Weight 2.2 oz. (62.4 g)		

PARACHUTE RECOVERY

Parts List

EXPLODED VIEW

- A 1 Balsa Nose Cone...BNC-55F
- B 3 Balsa Nose Cones .BNC-5W
- C 4 Balsa Nose Cones .BNC-5E
- D 1 Body Tube.....BT-55V
- E 3 Body TubesBT-5C
- F 1 Body Tube.....BT-5SE
- G 1 Body Tube.....ST-730E
- H 1 Ring Set.....CR-7-55EH
- I 1 Tail ConeIKV-85S
- J 1 Engine Hook.....EH-28
- K 1 Screw EyeSE-12
- L 1 Elastic CordEC-136
- M 1 Washer WeightWW-8
- N 1 Kevlar® ThreadSCK-18
- O 1 Chute PakCP-16Y
- P 2 Wood Dowels.....WD-140
- Q 1 Launch Lug.....LL-140
- R 1 Laser Cut Fins.....FV-85
- S 1 Laser Cut StripFV-85S
- T 1 Launch Lug.....LL-2A
- U 3 Wood Dowels.....WD-128
- V 1 Decal SetDKV-85

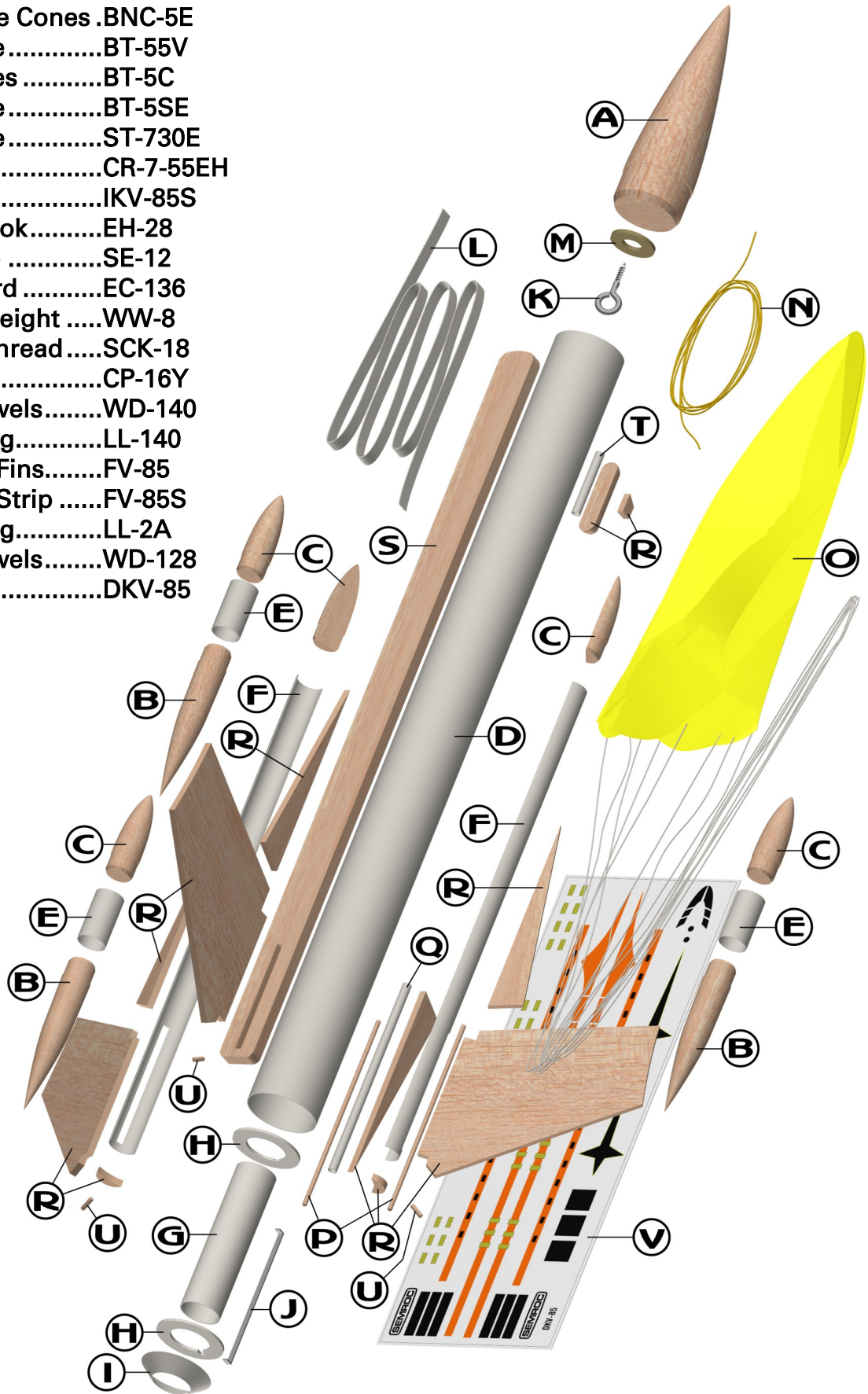

BEFORE YOU START!

Make sure you have all the parts included in this kit that are listed in the Parts List in these instructions. In addition to the parts included in this kit, you will also need the tools and materials listed below. Read the entire instructions before beginning to assemble your rocket. When you are thoroughly familiar with these instructions, begin construction. Read each step and study the accompanying drawings. Check off each step as it is completed. In each step, test-fit the parts together before applying any glue. It is sometimes necessary to sand lightly or build-up some parts to obtain a precision fit. If you are uncertain of the location of some parts, refer to the exploded view to the left. It is important that you always ensure that you have adequate glue joints.

TOOLS

In addition to the parts supplied, you will need the following tools to assemble and finish this kit. Wax paper is also required.



ASSEMBLY

1. These instructions are presented in a logical order to help you put your Starship Excalibur™ together quickly and efficiently. Check off each step as you complete it and we hope you enjoy putting this kit together.

FIN PREPARATION

2. Lightly sand each side of the laser-cut fin sheet (FV-85). Carefully push the laser-cut fins from their sheet. Start at one point on each fin and slowly and gently work around the fin.

3. Stack all the like fins in sets. Line each set of fins up squarely and sand the fins back and forth over some fine sandpaper to get rid of the hold-in tabs as shown below.

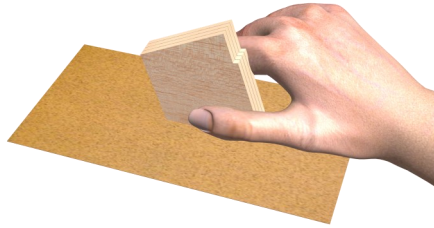

4. Identify the fins from the drawing below. There are two pod fins with longer tabs and one rudder fin. There are four vanes. Do not round any of the edges.



5. Using a sheet of wax paper, glue one vane fin to one of the pod fins. Make sure the root edges line up as shown. Repeat with the other pod fin and rudder using two of the remaining vanes.



ENGINE MOUNT

6. Bend the engine hook (EH-28) slightly so it forms a slight bow in the direction shown.



7. Tie a loop in one end of the yellow Kevlar® cord (SCK-18). Pull knot tight.



8. Insert one end of the engine hook (EH-28) through the loop in the Kevlar cord and into the pre-punched engine tubes (ST-730E).

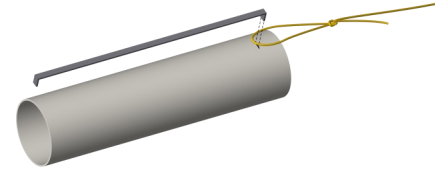

9. Carefully remove the two centering rings from the laser-cut sheet (CR-7-55EH). Select the one with the small notch and align it over the engine hook from the bottom of the engine tube until it is against the end of the engine hook and against the yellow Kevlar® cord.

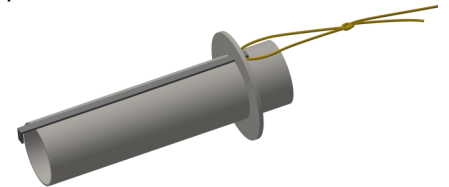

10. Wrap masking tape around the center of the engine tube to hold the engine hook in place and centered along its length. Run a bead of glue over the masking tape and along the engine hook between the tape and the ring. Allow to dry.

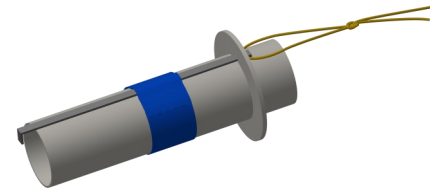

11. Align the remaining centering ring with the large notch over the engine hook and slide it from the bottom of the engine tube until it is 1/2" from the bottom of the engine tube. Apply a bead of glue around both sides of both centering rings and against the engine tube. Keep glue away from the outer edges of both rings and from the notch in the lower ring. Make sure the engine hook moves freely. Allow to dry in an upright position.

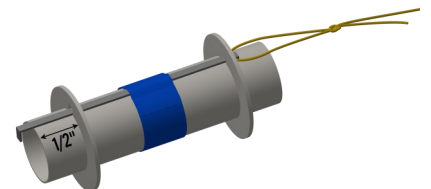

CREW MODULE

- ❑ 12. Using a sheet of sandpaper wrapped around the long body tube (BT-55V), sand a concave shape on one side of the crew module strip (FV-85S). Then sand both sides at a slight angle using the end view as a guide.



- ❑ 13. Cut one of the small nose cones (BNC-5E) into two identical halves. Using the sandpaper wrapped around the main tube, sand each half in a concave shape until the outside edges of the nose cone shoulder just touch the sandpaper.

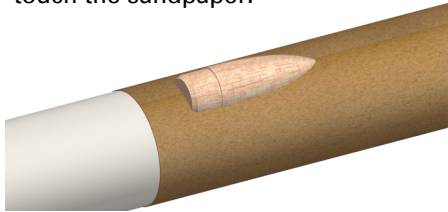

SHUTTLE BAY

- ❑ 14. Punch out the three rectangular pieces that make up the shuttle bay from the laser-cut sheet (FV-85). Glue the two small strips on the larger strip as shown. Allow to dry.



- ❑ 15. Using the same sandpaper on the main tube, sand a concave shape on the two side pieces as shown. Round the bottom piece.



- ❑ 16. Glue the short launch lug (LL-2A) inside the assembly. Round the front and back ends as shown.

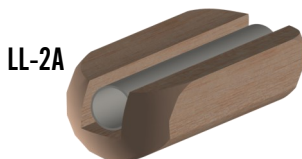

MARK TUBES

- ❑ 17. Stand the large body tube (BT-55V) on the fin guide below and make the position marks on the sides of the tube designated by the arrows. Mark the LL line for launch lug placement. Find a convenient channel or groove such as a partially open drawer, a door jamb (as shown,) or a piece of molding. Using the channel, extend all seven the entire length of the tube. Refer to the marking guide later to see the placements of the crew module and reactor bays.

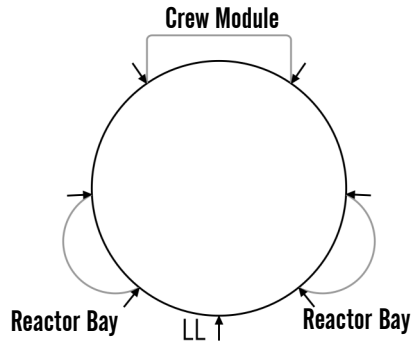

- ❑ 18. Using the same channel, mark the long reactor bay tube (BT-5SE) at the two small laser-cut marks between the two slots. Using a sharp hobby knife, cut the tube into two identical halves along the marked lines

REACTOR BAY

- ❑ 19. Remove the two small reactor bay end caps from the laser cut sheet (FV-85). Glue one at the end of each of the two reactor bay tubes at the slotted end.



- ❑ 20. Glue a nose cone half at the opposite end of each of the reactor tubes. Apply to dry.



- ❑ 21. Glue one of the reactor bays on the main body tube aligned with one set of lines marked for the reactor bays. Make sure the slotted end is flush with the bottom of the main tube. Repeat with the other reactor bay assembly. Allow to dry.



- ❑ 22. Glue the crew module on the main body tube along the set of lines drawn earlier. Offset it 1/4" from the end of the main tube. Allow to dry.

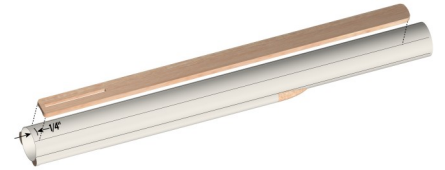

POD ASSEMBLY

- ❑ 23. Apply a bead of glue inside one end of one of the pod tubes (BT-5C). Insert one of the three long nose cones (BNC-5W) in the tube. Sand the shoulder slightly until it is the same diameter as the body tube.



- ❑ 24. Apply a bead of glue inside the opposite end of the pod tube. Insert one of the three short nose cones (BNC-5E) in the tube. Sand the shoulder slightly until it is the same diameter as the body tube. This end will be the top of the assembly. Glue both nose cones in the two remaining pod tube assemblies. Allow them to completely dry.



- ❑ 25. Glue one of the pod assemblies to one of the pod fins or the rudder fins aligning the tip of the nose cone with the trailing edge of the fin. Repeat with the other two pods with the remaining main fins.



ATTACH FINS

□ 26. Apply glue to the root edge of the completed pod assembly using the rudder fin (with the shorter tab) and position it with the tab centered in the slot in the crew module. Remove the fin, set it aside and allow it to almost dry, apply additional glue, and reposition. If you follow these instructions, the fins will not require much additional work to keep them aligned. Allow the fin to completely dry, checking carefully to make sure it is parallel with the main body tube.

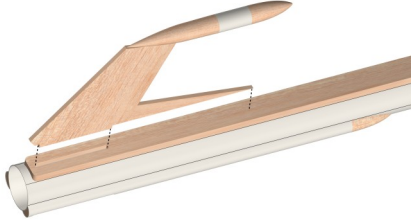

□ 27. Apply glue to the root edge of one of the remaining completed pod assembly and position it with the tab centered in the slot in the reactor bay. Remove the fin, set it aside and allow it to almost dry, apply additional glue, and reposition. Allow the fins to completely dry, checking carefully to make sure they are parallel with the main body tube.

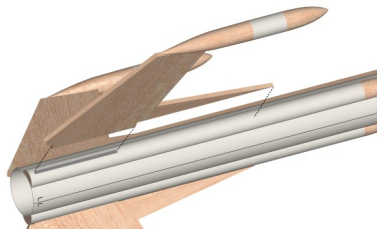

ENGINE MOUNT

□ 28. Apply a thick bead of glue inside the aft end of the main body tube and on the top side of the bottom ring, keeping glue away from the engine hook slot. Pull the Kevlar cord back through the engine mount and out the back of the engine tube. Insert the engine mount assembly with the thrust ring end first into the main body tube until the bottom ring is just inside the main body tube and the engine hook is centered on the LL line. Do not stop until it is in the correct place. Allow to dry completely in a vertical position.

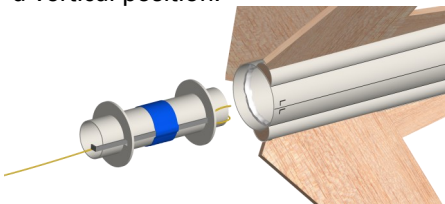

SHROUD

□ 29. Carefully cut out the paper shroud (IKV-85S). Roll it carefully forming it into a cone (glossy side out), being careful to avoid creasing the paper. Apply a thin layer of white glue on the indicated section inside the dotted line. Line up the opposite edge with the dotted line and press together on a flat surface. Hold it in place until the glue sets. Allow to dry.

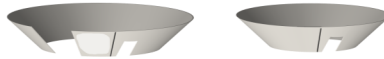

□ 30. Apply a thin bead of glue inside the aft end of the main body tube on the outer edge of the bottom centering ring. Align the shroud over the engine hook and centered on the bottom ring. Run a fillet of glue around the bottom of the shroud against the engine tube, keeping glue away from the engine hook.

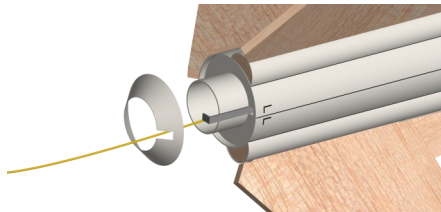

LAUNCH LUGS

□ 31. Glue the shuttle bay assembly with launch lug centered on the LL line and 1-3/8" from the front of the main body tube.

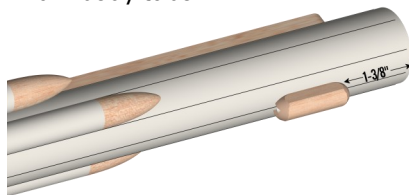

□ 32. Remove the shuttle bay antenna from the fin sheet (FV-85) and attach it to the bottom of the shuttle bay.

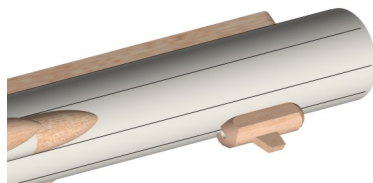

□ 33. Glue the long launch lug (LL-140) on the LL line and even with the bottom of the main tube. Allow to dry.



LL-140

□ 34. Apply a bead of glue to each side of the long launch and attach one of the long wood dowels (WD-140) on each side of the launch lug against the main body tube. Allow to dry.

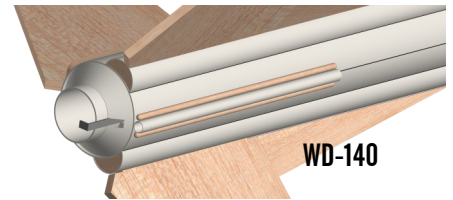

WD-140

□ 35. Apply a bead of glue to the root edge of the remaining vane and attach to the bottom of the long launch lug. Allow to dry.

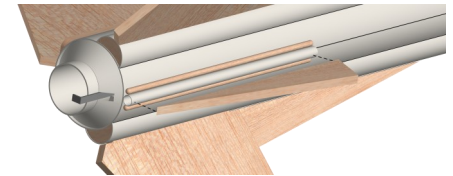

□ 36. Apply a bead of glue to the small trailing edge of each main fin and attach a small wood dowel (WD-128) to each. At this time, the long trailing edges and the leading edges may be rounded or left flat.

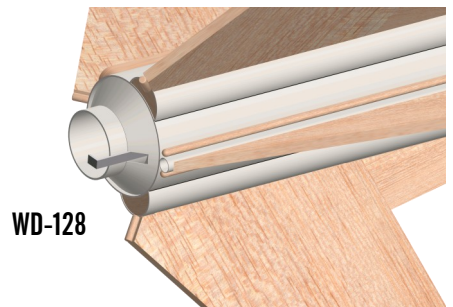

WD-128

NOSE CONE

□ 37. Insert the nose cone (BNC-55F) in the main body tube and check for proper fit. The nose cone should be snug to hold itself in alignment. If it is too loose, add masking tape. If it is too tight, sand the shoulder slightly.

❑ **38.** Screw the screw eye (SE-12) into the base of the nose cone, remove and fill the hole with glue. Apply glue around the hole on the base of the nose cone, keeping it away from the shoulder. Insert the screw eye through the washer weight (WW-8) and reinsert the screw into the nose cone until the weight is against the nose cone and the eye is securely against the weight. Wipe any glue that comes out from the washer weight. Allow to dry.

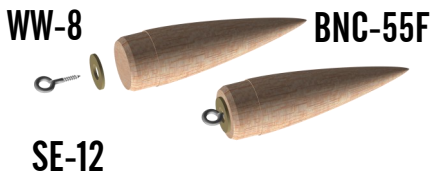

APPLY FILLETS

❑ **39.** After all joints are completely dry, run a small bead of glue along both sides of each fin-body tube joint, the launch lug assemblies and the reactor tube assemblies. Using your forefinger, smooth the glue into fillets. Apply a fillet of glue on each side of the launch lugs. Allow this assembly to dry in a vertical position.

FINAL ASSEMBLY

❑ **40.** Tie the free end of the Kevlar® cord to one end of the elastic cord (EC-136) using an overhand knot. Pull the elastic cord and Kevlar cord back through the main body tube and out the top of the tube.

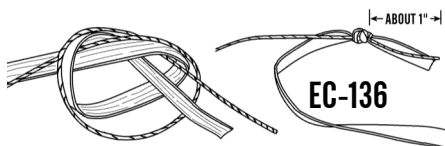

❑ **41.** Assemble the chute (CP-16Y) using instructions provided with it. Pull the lines tight on the chute and make sure they are all of equal length. Attach the chute by tying them to the screw eye. Put a drop of glue on the joint to keep the lines from moving. Attach the free end of the elastic cord to the screw eye. Put a drop of glue on that joint as well.

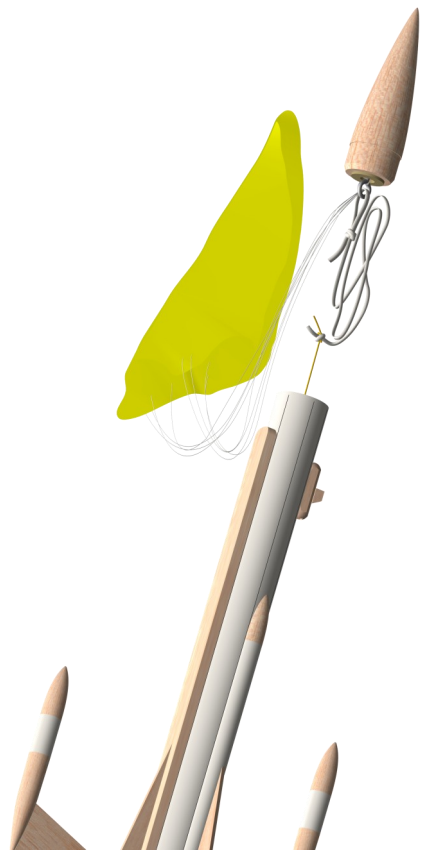

FINISHING

❑ **42.** When the fillets have dried, prepare balsa surfaces for a smooth professional looking finish. Fill the wood grain with balsa fillercoat or sanding sealer. When dry, sand with fine sandpaper. Repeat until smooth.

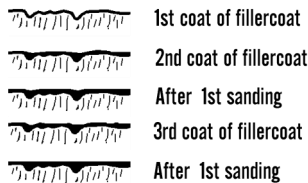

❑ **43.** After all balsa surfaces have been prepared, wipe off all balsa dust with a dry cloth. First spray the model with an enamel primer. Choose high visibility colors like white for the final color.

❑ **44.** Spray painting your model with a fast-drying enamel will produce the best results. PATIENCE...is the most important ingredient. Use several thin coats, allowing each coat to completely dry before the next coat. Start each spray a few inches above the model and end a few inches below the model. Keep the can about 12" away and use quick light coats. The final coat can be a little heavier to give the model a glossy wet-looking finish.

❑ **45.** After the paint has dried, decals should be applied. The decals supplied with the Starship Excalibur™ are waterslide decals. Each decal should be cut separately from the sheet. Think about where you want to apply each decal and check for fit before wetting the decal. Use the cover photo for suggested placement. Dip each decal in a small dish of water that has a drop of detergent. It will take about 30 seconds before the decal is loose enough to apply.

❑ **46.** Slide the decal in place and use the paper backing to work the bubbles out. Repeat for all the decals.

FLIGHT PREPPING

❑ **47.** Mounting the engine: Insert the engine and make sure the engine hook keeps the engine in snugly. The hook may be slightly bent to make sure the engine is retained.

❑ **48.** Apply a few sheets of recovery wadding in the top of the body tube. Fold the parachute and pack it and the shock cord on top of the recovery wadding. Slide the nose cone into place, making sure it does not pinch the shock cord or parachute.

❑ **49.** Refer to the model rocket engine manufacturer's instructions to complete the engine prepping. Different engines have different igniters and methods of hooking them up to the launch controllers.

❑ **50.** Carefully check all parts of your rocket before each flight as a part of your pre-flight checklist. Launch the Starship Excalibur™ from a 1/8" diameter by 36" long launch rod.

❑ **51.** After each flight, promptly remove the spent engine casing and dispose of properly.